

50/60 Hz

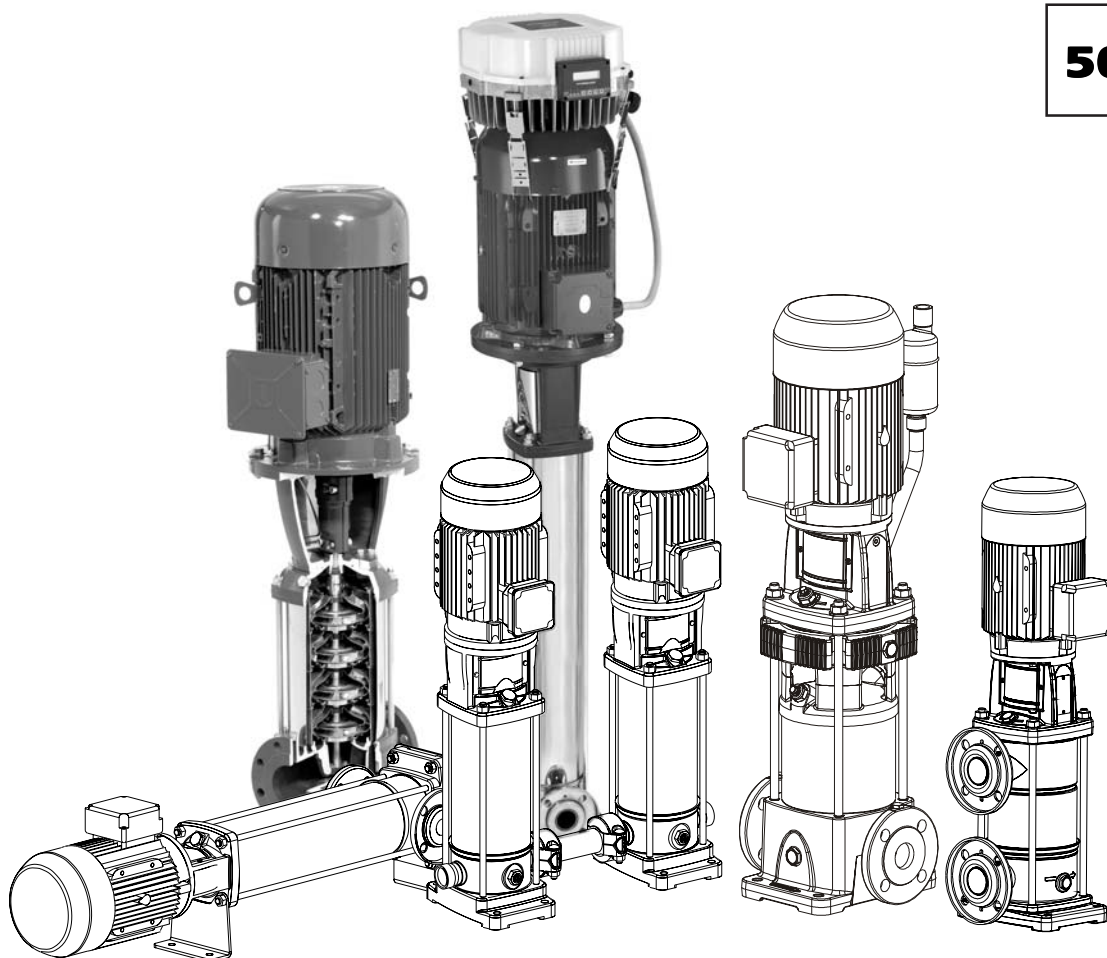

e-SV™ Series



1, 3, 5, 10, 15, 22
33, 46, 66, 92, 125

SPECIAL VERSIONS

Cod. 191002041 Rev.D Ed.06/2012

 **LOWARA**
a xylem brand

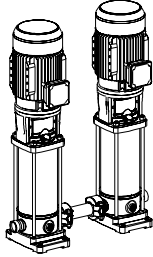
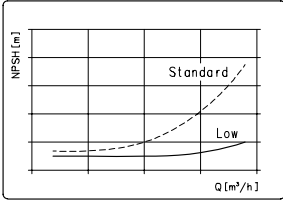
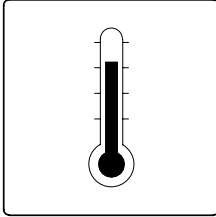
CONTENTS

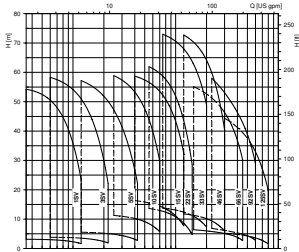
<p>INTRODUCTION</p>	<p>5</p>
<p>HIGH PRESSURE (50/60 Hz) Water treatment industry - washing and cleaning</p> <ul style="list-style-type: none"> - Versatile range - Long lasting performances - Easy installation and maintenance 	 <p>15</p>
<p>LOW NPSH (50/60 Hz) Solving cavitation issues in installation</p> <ul style="list-style-type: none"> - Consistent operation - Long lasting performances - Easy installation 	 <p>65</p>
<p>HIGH TEMPERATURE Electric pumps for high temperature applications</p> <ul style="list-style-type: none"> - H versions for temperature values up to 150°C - B "BOILER" versions for temperature values up to 180°C 	 <p>107</p>
<p>e-SVH - e-SV™ WITH HYDROVAR® An evolution of e-SV™ special version toward a variable speed intelligent system</p>	 <p>123</p>
<p>4-POLE VERSION (50/60 Hz) Silencious operation</p> <ul style="list-style-type: none"> - Low level of noise - Wide range of performances - Increased performance with Hydrovar® 	 <p>157</p>

CONTENTS

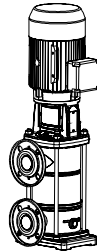
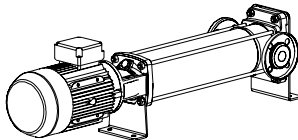
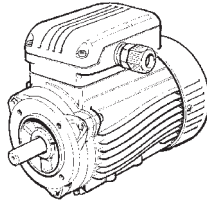
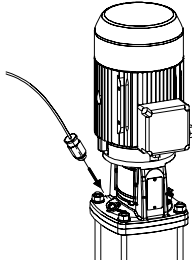
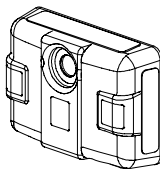
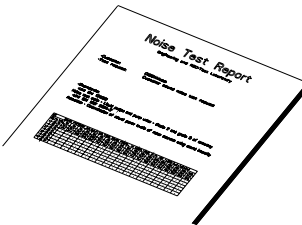
<p>REDUCING FOOTPRINT (50/60 Hz) Space saving in installation</p> <ul style="list-style-type: none"> - Compact design - Versatile design - High level performances 	 <p style="text-align: right;">211</p>
<p>HORIZONTAL VERSION (50/60 Hz) Installation in reduced vertical space or in seismic area</p> <ul style="list-style-type: none"> - Reduced vertical space - Easy installation 	 <p style="text-align: right;">213</p>
<p>MOTORS Wide range of high efficiency motors</p> <ul style="list-style-type: none"> - 50 and 60 Hz - Wide range of voltages - Wide range of standard options 	 <p style="text-align: right;">219</p>
<p>PROTECTION SENSOR AGAINST DRY RUNNING Sensor for detecting the lack of liquid</p>	 <p style="text-align: right;">231</p>
<p>i-ALERT™ - CONDITIONAL MONITORING Reduce life cycle cost by increasing Mean Time Between Failures (MTBF)</p>	 <p style="text-align: right;">235</p>
<p>CERTIFICATES List of the main tests and certificates available for e-SV™</p>	 <p style="text-align: right;">239</p>

CONTENTS

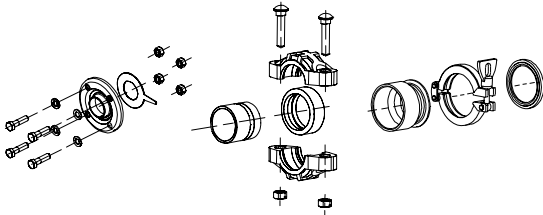
<p>ACCESSORIES Wide range of accessories for connection and installation</p> 	<p>241</p>
<p>TECHNICAL APPENDIX</p>	<p>253</p>

INTRODUCTION

e-SV™ SERIES - SPECIAL VERSIONS

Introduction

Our customers are central to our business. Many years of collaboration with them across the different markets and all over the world has taught us that specifically designed pumps are required to handle special applications or to fulfill particular installations. It is essential to ensure top performance of the systems and continuous quality of the production. Therefore Lowara has developed a wide range of special versions of its vertical multistage e-SV™ to give an appropriate and dedicated solution to special applications and installations in the industry or in the building services market.

Pump design

Non-self priming, vertical multistage, high pressure centrifugal pump, with suction inlet and outlet of the same identical nominal diameters, coupled to a standard motor. Horizontal installation also available, see specific section.

Drive

Without speed control: Electric short-circuit squirrel-cage motor (TEFC), enclosed construction, air-cooled, three-phase, 2-pole and 4-pole, efficiency class **IE2/IE3** from 0,75kW (compliant with Regulation (EC) no. 640/2009 and IEC 60034-30). Single-phase version up to 2,2 kW (with built-in automatic reset overload protection up to 1,5kW).

With Hydrovar® speed control system: A special version of e-SV™ which becomes an intelligent, variable speed system. Ideal for single pumping solution or multiple pumping set solution (up to 8 pumps). See specific section of e-SVH – Hydrovar® fitted.

For more motor options see the specific motors section.



Special versions and options index

The first part of this booklet will cover the following special versions:

- e-SV™ – High Pressure - 50/60 Hz
- e-SV™ – Low NPSH - 50/60 Hz
- e-SV™ – High Temperature - 150°C & 180°C
- e-SV™ – with Hydrovar® - SVH
- e-SV™ – 4-pole version - 50/60 Hz
- e-SV™ – Reducing footprint - 50/60 Hz
- e-SV™ – Horizontal version - 50/60 Hz

The second part of this booklet will cover the following sections:

- Motors configuration and standard options
- Dry-running sensor
- i-Alert device
- Tests and certifications
- Accessories

Documentation and support

Pump selection software, visit:
<http://www.xylect.com>

Documentation is also available on:
<http://www.lowara.com>

Visit us for information including video, commercial leaflet, brochure, other technical catalogues, 2D and 3D drawings, IOM.

e-SV™ SERIES - SPECIAL VERSIONS

COMPATIBILITY MATRIX

The following table describes the recommended compatibility between the special versions of e-SV™.

SPECIAL VERSIONS	Low NPSH	High pressure	High Temperature 150° & 180°C	Version with Hydrovar®	Reducing footprint "R"	Horizontal version	4 Pole
Low NPSH		•	•	•	•	•	△
High pressure	•		N/A	•	N/A	•	△
High Temperature 150° & 180°C	•	N/A		N/A	N/A	N/A	△
Version with Hydrovar®	•	•	N/A		•	•	•
Reducing footprint "R"	•	N/A	N/A	•		△	•
Horizontal version	•	•	N/A	•	△		•
4-Pole	△	△	△	•	•	•	

* = Available. △ = su richiesta. N/A = not available.

sv-spec-en_b_tc

As a global supplier, Lowara can design specific solutions according to the requirements of the application or of the installation. For example, Lowara's custom-built solutions can handle more aggressive liquids or heavy duty applications. For more information, refer to the Lowara sales network.

1, 3, 5SV SERIES and 10, 15, 22SV SERIES ≤ 4 kW ELECTRIC PUMP CROSS SECTION AND MAIN COMPONENTS

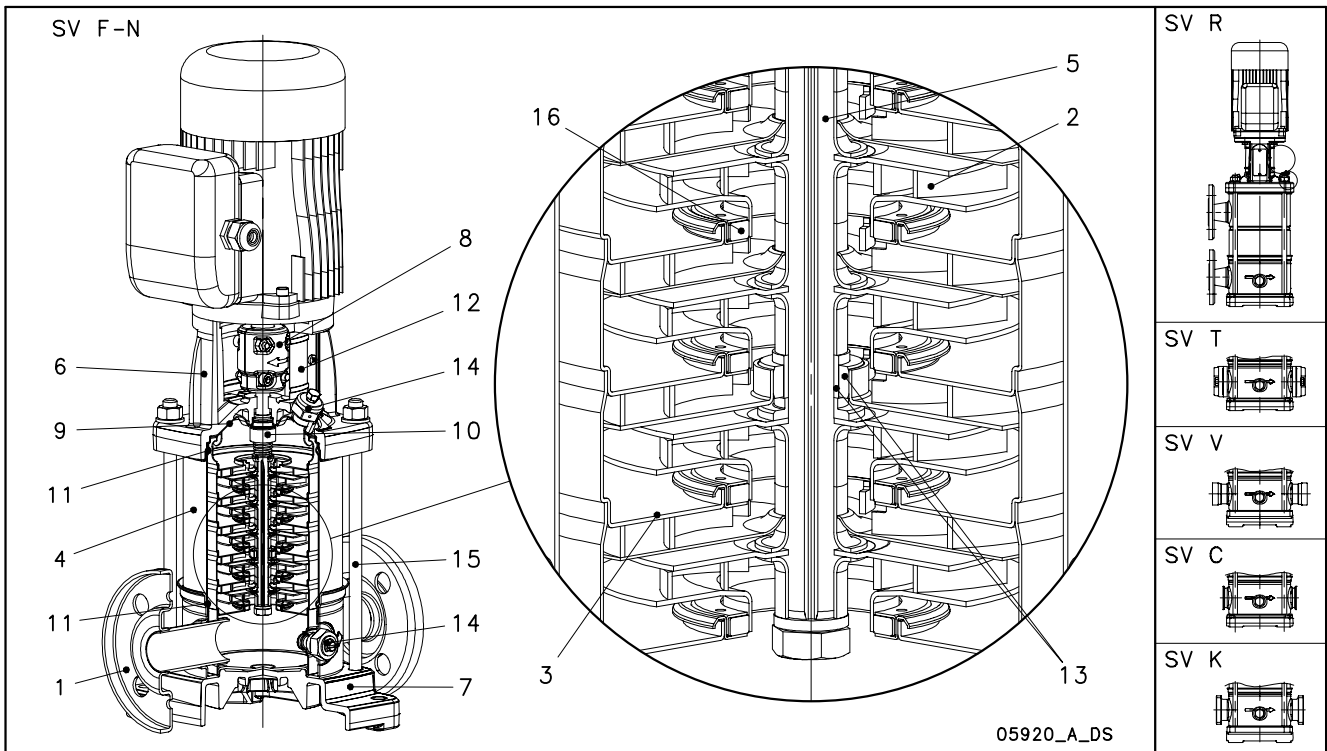

F, T, R VERSIONS

REF. N.	NAME	MATERIAL	REFERENCE STANDARDS	
			EUROPE	USA
1	Pump body	Stainless steel	EN 10088-1-X5CrNi18-10 (1.4301)	AISI 304
2	Impeller	Stainless steel	EN 10088-1-X5CrNi18-10 (1.4301)	AISI 304
3	Diffuser	Stainless steel	EN 10088-1-X5CrNi18-10 (1.4301)	AISI 304
4	Outer sleeve	Stainless steel	EN 10088-1-X5CrNi18-10 (1.4301)	AISI 304
5	Shaft	Stainless steel	EN 10088-1-X5CrNi18-10 (1.4301)	AISI 304
6	Adapter	Cast iron	EN 1561-GJL-250 (JL1040)	ASTM Class 35
7	Base	Aluminium	EN 1706-AC-ALSi11Cu2 (Fe) (AC46100)	-
8	Coupling	Aluminium	EN 1706-AC-ALSi11Cu2 (Fe) (AC46100)	-
9	Seal housing	Stainless steel	EN 10088-1-X5CrNi18-10 (1.4301)	AISI 304
10	Mechanical seal	Silicon carbide / Carbon / EPDM		
11	Elastomers	EPDM		
12	Coupling protection	Stainless steel	EN 10088-1-X5CrNi18-10 (1.4301)	AISI 304
13	Shaft sleeve and bushing	Tungsten carbide		
14	Fill / drain plugs	Stainless steel	EN 10088-1-X5CrNi18-10 (1.4301)	AISI 304
15	Tie rods	Galvanized steel	EN 10277-3-36SMnPb14 (1.0765)	
16	Wear ring	Technopolymer PPS		

1-22sv-frm-en_a_tm

N, V, C, K VERSIONS

REF. N.	NAME	MATERIAL	REFERENCE STANDARDS	
			EUROPE	USA
1	Pump body	Stainless steel	EN 10088-1-X2CrNiMo17-12-2 (1.4404)	AISI 316L
2	Impeller	Stainless steel	EN 10088-1-X2CrNiMo17-12-2 (1.4404)	AISI 316L
3	Diffuser and upper spacer	Stainless steel	EN 10088-1-X2CrNiMo17-12-2 (1.4404)	AISI 316L
4	Outer sleeve	Stainless steel	EN 10088-1-X2CrNiMo17-12-2 (1.4404)	AISI 316L
5	Shaft	Stainless steel	EN 10088-1-X5CrNiMo17-12-2 (1.4401)	AISI 316
6	Adapter	Cast iron	EN 1561-GJL-250 (JL1040)	ASTM Class 35
7	Base	Aluminium	EN 1706-AC-ALSi11Cu2 (Fe) (AC46100)	-
8	Coupling	Aluminium	EN 1706-AC-ALSi11Cu2 (Fe) (AC46100)	-
9	Seal housing	Stainless steel	EN 10088-1-X2CrNiMo17-12-2 (1.4404)	AISI 316L
10	Mechanical seal	Silicon carbide / Carbon / EPDM		
11	Elastomers	EPDM		
12	Coupling protection	Stainless steel	EN 10088-1-X5CrNi18-10 (1.4301)	AISI 304
13	Shaft sleeve and bushing	Tungsten carbide		
14	Fill / drain plugs	Stainless steel	EN 10088-1-X5CrNiMo17-12-2 (1.4401)	AISI 316
15	Tie rods	Stainless steel	EN 10088-1-X17CrNi16-2 (1.4057)	AISI 431
16	Wear ring	Technopolymer PPS		

1-22sv-nvck-en_a_tm

10, 15, 22SV SERIES ≥ 5,5 kW ELECTRIC PUMP CROSS SECTION AND MAIN COMPONENTS

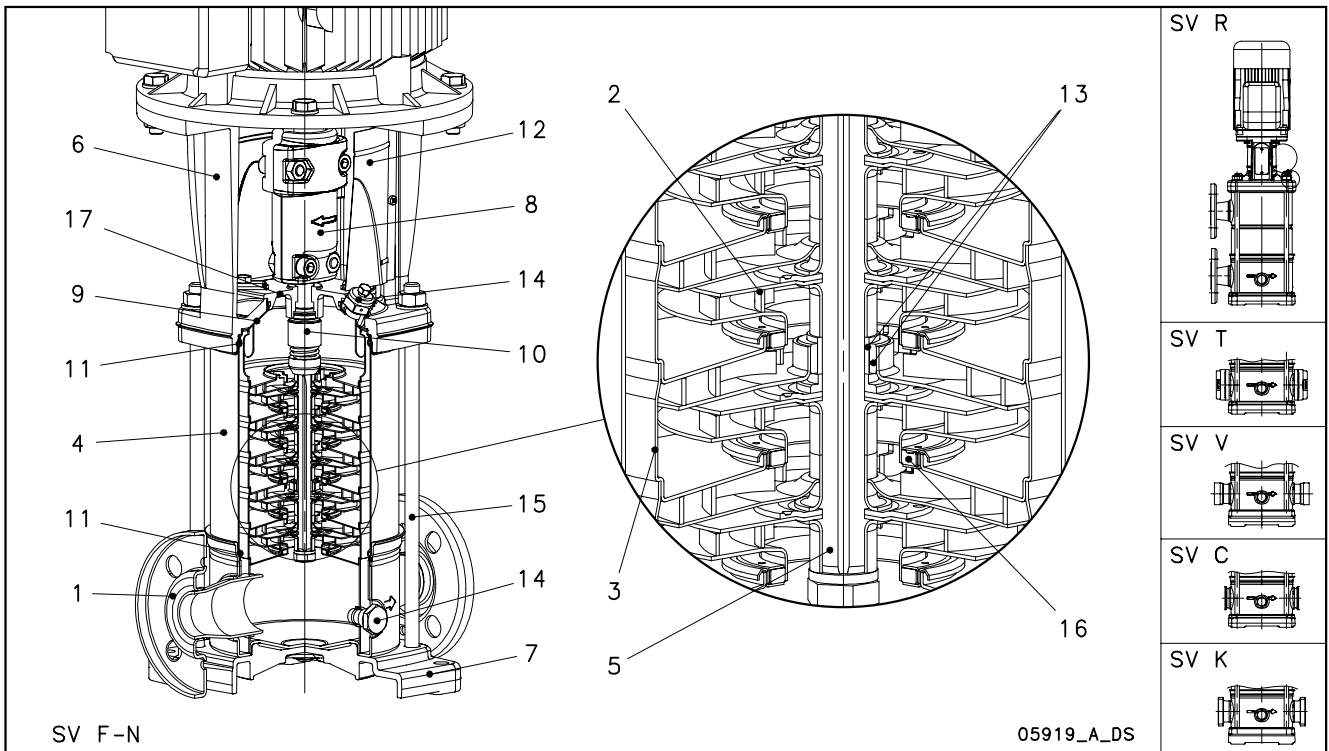

INTRODUCTION

F, T, R VERSIONS

REF. N.	NAME	MATERIAL	REFERENCE STANDARDS	
			EUROPE	USA
1	Pump body	Stainless steel	EN 10088-1-X5CrNi18-10 (1.4301)	AISI 304
2	Impeller	Stainless steel	EN 10088-1-X5CrNi18-10 (1.4301)	AISI 304
3	Diffuser	Stainless steel	EN 10088-1-X5CrNi18-10 (1.4301)	AISI 304
4	Outer sleeve	Stainless steel	EN 10088-1-X5CrNi18-10 (1.4301)	AISI 304
5	Shaft	Stainless steel	EN 10088-1-X5CrNi18-10 (1.4301)	AISI 304
6	Adapter	Cast iron	EN 1561-GJL-250 (JL1040)	ASTM Class 35
7	Base	Aluminium	EN 1706-AC-AISI11Cu2 (Fe) (AC46100)	-
8	Coupling	Aluminium	EN 1706-AC-AISI11Cu2 (Fe) (AC46100)	-
9	Seal plate	Stainless steel	EN 10088-1-X5CrNi18-10 (1.4301)	AISI 304
10	Mechanical seal	Silicon carbide / Carbon / EPDM		
11	Elastomers	EPDM		
12	Coupling protection	Stainless steel	EN 10088-1-X5CrNi18-10 (1.4301)	AISI 304
13	Shaft sleeve and bushing	Tungsten carbide		
14	Fill / drain plugs	Stainless steel	EN 10088-1-X5CrNi18-10 (1.4301)	AISI 304
15	Tie rods	Stainless steel	EN 10277-3-36SMnPb14 (1.0765)	
16	Wear ring	Technopolymer PPS		
17	Seal gland	Stainless steel	EN 10213-4-GX5CrNi19-10 (1.4308)	AISI 304

N, V, C, K VERSIONS

REF. N.	NAME	MATERIAL	REFERENCE STANDARDS	
			EUROPE	USA
1	Pump body	Stainless steel	EN 10088-1-X2CrNiMo17-12-2 (1.4404)	AISI 316L
2	Impeller	Stainless steel	EN 10088-1-X2CrNiMo17-12-2 (1.4404)	AISI 316L
3	Diffuser	Stainless steel	EN 10088-1-X2CrNiMo17-12-2 (1.4404)	AISI 316L
4	Outer sleeve	Stainless steel	EN 10088-1-X2CrNiMo17-12-2 (1.4404)	AISI 316L
5	Shaft	Stainless steel	EN 10088-1-X5CrNiMo17-12-2 (1.4401)	AISI 316
6	Adapter	Cast iron	EN 1561-GJL-250 (JL1040)	ASTM Class 35
7	Base	Aluminium	EN 1706-AC-AISI11Cu2 (Fe) (AC46100)	-
8	Coupling	Aluminium	EN 1706-AC-AISI11Cu2 (Fe) (AC46100)	-
9	Seal plate	Stainless steel	EN 10088-1-X2CrNiMo17-12-2 (1.4404)	AISI 316L
10	Mechanical seal	Silicon carbide / Carbon / EPDM		
11	Elastomers	EPDM		
12	Coupling protection	Stainless steel	EN 10088-1-X5CrNi18-10 (1.4301)	AISI 304
13	Shaft sleeve and bushing	Tungsten carbide		
14	Fill / drain plugs	Stainless steel	EN 10088-1-X5CrNiMo17-12-2 (1.4401)	AISI 316
15	Tie rods	Stainless steel	EN 10088-1-X17CrNi16-2 (1.4057)	AISI 431
16	Wear ring	Technopolymer PPS		
17	Seal gland	Stainless steel	EN 10213-4-GX5CrNiMo19-11-2 (1.4408)	AISI 316

10-22sv-frm-en_a_tm

10-22sv-nvck-en_a_tm

33, 46, 66, 92SV SERIES ELECTRIC PUMP CROSS SECTION AND MAIN COMPONENTS

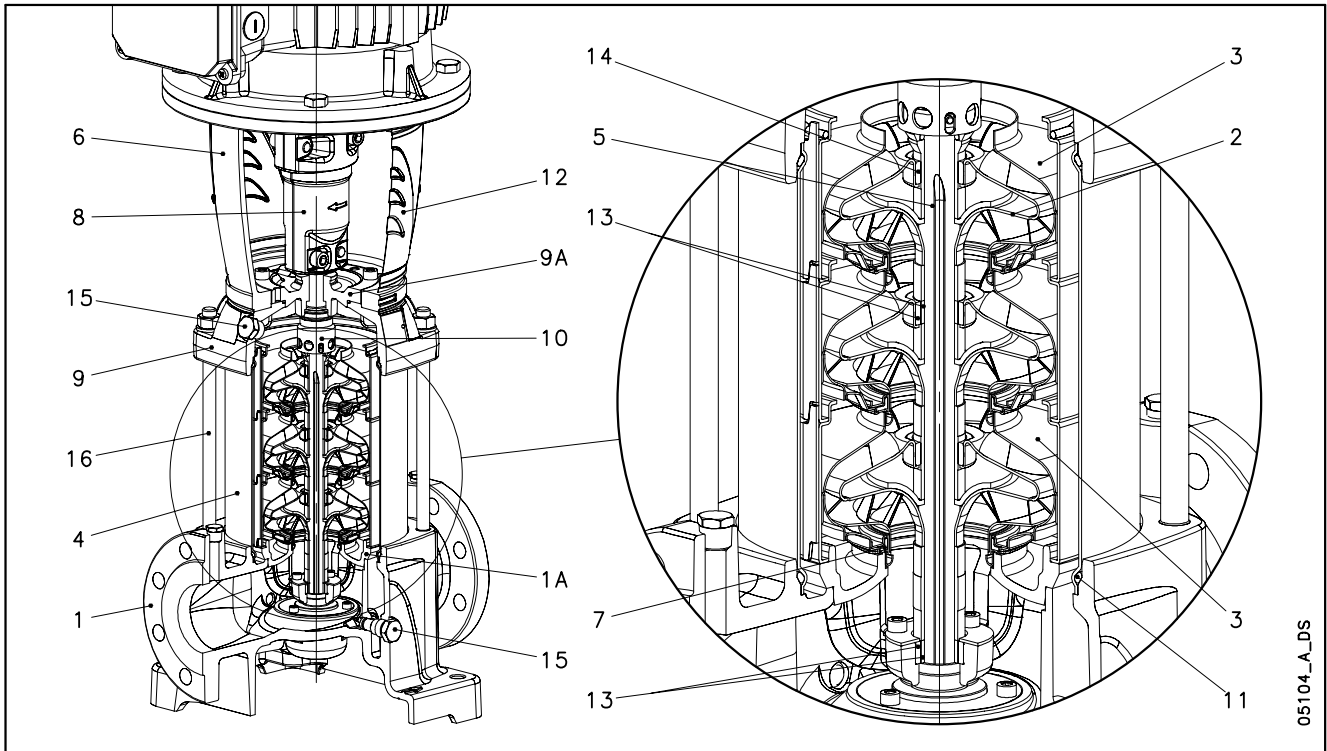

05104_A_DS

G VERSIONS

REF. N.	NAME	MATERIAL	REFERENCE STANDARDS	
			EUROPE	USA
1	Pump body	Cast iron	EN 1561-GJL-250 (JL1040)	ASTM Class 35
1A	Lower support	Cast iron	EN 1561-GJL-250 (JL1040)	ASTM Class 35
2	Impeller	Stainless steel	EN 10088-1-X2CrNiMo17-12-2 (1.4404)	AISI 316L
3	Diffuser	Stainless steel	EN 10088-1-X5CrNi18-10 (1.4301)	AISI 304
4	Outer sleeve	Stainless steel	EN 10088-1-X5CrNi18-10 (1.4301)	AISI 304
5	Shaft	Stainless steel	EN 10088-1 - X17CrNi16-2 (1.4057)	AISI 431
6	Adapter	Cast iron	EN 1561-GJL-200 (JL1030)	ASTM Class 25
7	Wear ring	Technopolymer PPS		
8	Coupling	Cast iron	EN 1561-GJL-200 (JL1030)	ASTM Class 25
9	Upper head	Cast iron	EN 1561-GJL-250 (JL1040)	ASTM Class 35
9A	Seal housing	Cast iron	EN 1561-GJL-250 (JL1040)	ASTM Class 35
10	Mechanical seal	Silicon carbide / Carbon / EPDM		
11	Elastomers	EPDM		
12	Coupling protection	Stainless steel	EN 10088-1-X5CrNi18-10 (1.4301)	AISI 304
13	Shaft sleeve and bushing	Tungsten carbide		
14	Bushing for diffuser	Carbon		
15	Fill / Drain plugs	Stainless steel	EN 10088-1-X5CrNiMo17-12-2 (1.4401)	AISI 316
16	Tie rods	Galvanized steel	EN 10277-3-36SMnPb14 (1.0765)	-

33-92sv-g-en_a_tm

N VERSIONS

REF. N.	NAME	MATERIAL	REFERENCE STANDARDS	
			EUROPE	USA
1	Pump body	Stainless steel	EN 10213-4-GX5CrNiMo19-11-2 (1.4408)	ASTM CF8M (AISI 316 cast)
1A	Lower support	Stainless steel	EN 10213-4-GX5CrNiMo19-11-2 (1.4408)	ASTM CF8M (AISI 316 cast)
2	Impeller	Stainless steel	EN 10088-1-X2CrNiMo17-12-2 (1.4404)	AISI 316L
3	Diffuser	Stainless steel	EN 10088-1-X2CrNiMo17-12-2 (1.4404)	AISI 316L
4	Outer sleeve	Stainless steel	EN 10088-1-X2CrNiMo17-12-2 (1.4404)	AISI 316L
5	Shaft	Duplex stainless steel	EN 10088-1-X2CrNiMoN22-5-3 (1.4462)	UNS S 31803
6	Adapter	Cast iron	EN 1561-GJL-200 (JL1030)	ASTM Class 25
7	Wear ring	Technopolymer PPS		
8	Coupling	Cast iron	EN 1561-GJL-200 (JL1030)	ASTM Class 25
9	Upper head	Stainless steel	EN 10213-4-GX5CrNiMo19-11-2 (1.4408)	ASTM CF8M (AISI 316 cast)
9A	Seal housing	Stainless steel	EN 10213-4-GX5CrNiMo19-11-2 (1.4408)	ASTM CF8M (AISI 316 cast)
10	Mechanical seal	Silicon carbide / Carbon / EPDM		
11	Elastomers	EPDM		
12	Coupling protection	Stainless steel	EN 10088-1-X5CrNi18-10 (1.4301)	AISI 304
13	Shaft sleeve and bushing	Tungsten carbide		
14	Bushing for diffuser	Carbon		
15	Fill / drain / air plugs	Stainless steel	EN 10088-1-X5CrNiMo17-12-2 (1.4401)	AISI 316
16	Tie rods	Stainless steel	EN 10088-1-X17CrNi16-2 (1.4057)	AISI 431

33-92sv-n-en_a_tm

125SV SERIES ELECTRIC PUMP CROSS SECTION AND MAIN COMPONENTS

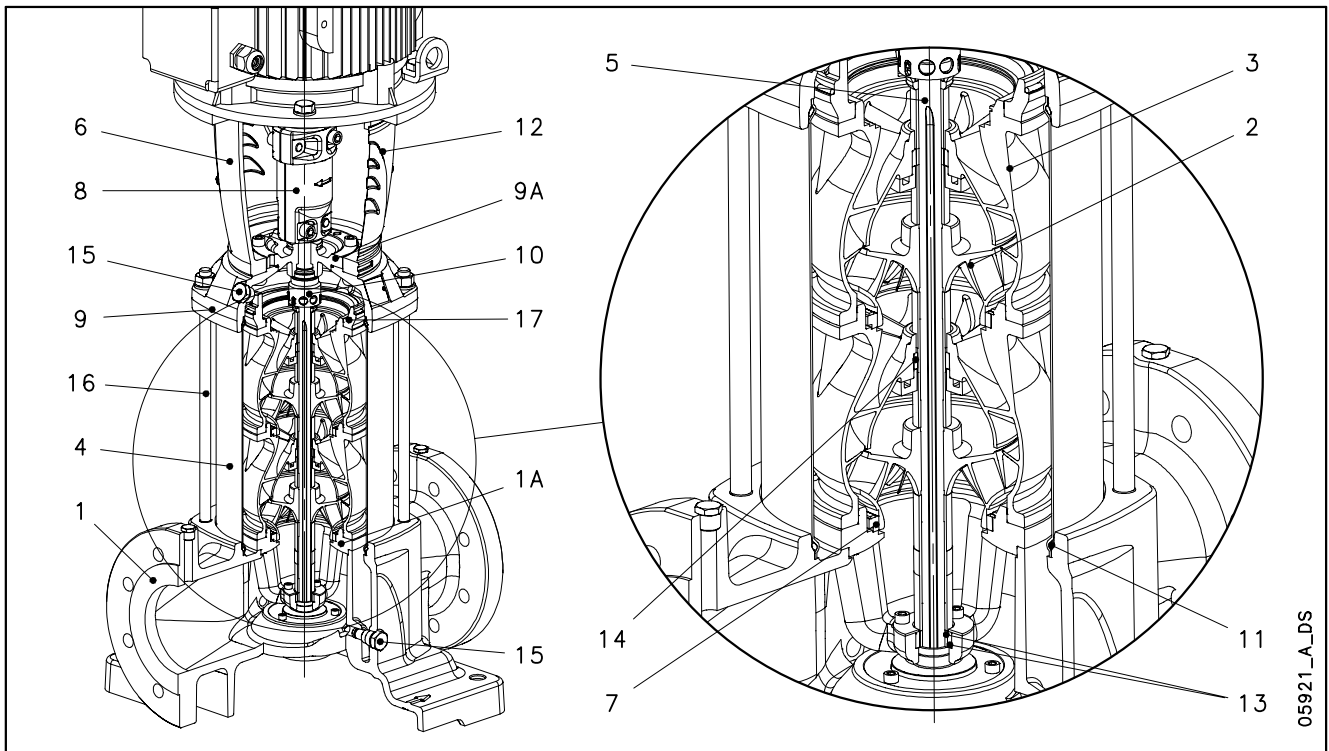

05921_A_DS

INTRODUCTION

G VERSIONS

REF. N.	NAME	MATERIAL	REFERENCE STANDARDS	
			EUROPE	USA
1	Pump body	Cast iron	EN 1561-GJL-250 (JL1040)	ASTM Class 35
1A	Lower support	Stainless steel	EN 10213-GX5CrNi19-10 (1.4308)	AISI 304
2-3	Impeller, Diffuser	Stainless steel	EN 10213-GX5CrNi19-10 (1.4308)	AISI 304
4	Outer sleeve	Stainless steel	EN 10088-1-X5CrNi18-10 (1.4301)	AISI 304
5	Shaft	Stainless steel	EN 10088-1 - X17CrNi16-2 (1.4057)	AISI 431
6	Adapter (up to 45kW)	Cast iron	EN 1561-GJL-200 (JL1030)	ASTM Class 25
6	Adapter (for higher powers)	Cast iron	EN 1563-GJS-500-7 (JS1050)	ASTM A 536 80-55-06
7	Wear ring	Technopolymer PPS		
8	Coupling (up to 45kW)	Cast iron	EN 1561-GJL-200 (JL1030)	ASTM Class 25
8	Coupling (for higher powers)	Cast iron	EN 1563-GJS-500-7 (JS1050)	ASTM A 536 80-55-06
9-9A	Upper head, Seal housing	Cast iron	EN 1561-GJL-250 (JL1040)	ASTM Class 35
10	Mechanical seal	Silicon carbide / Carbon / EPDM		
11	Elastomers	EPDM		
12	Coupling protection	Stainless steel	EN 10088-1-X5CrNi18-10 (1.4301)	AISI 304
13	Shaft sleeve and bushing	Tungsten carbide		
14	Bushing for diffuser	Carbon		
15	Fill / drain / air plugs	Stainless steel	EN 10088-1-X5CrNiMo17-12-2 (1.4401)	AISI 316
16	Tie rods	Galvanized steel	EN 10277-3-36SMnPb14 (1.0765)	-
17	Adapter ring	Stainless steel	EN 10213-GX5CrNi19-10 (1.4308)	AISI 304

125sv-g-en_a_tm

N VERSIONS

REF. N.	NAME	MATERIAL	REFERENCE STANDARDS	
			EUROPE	USA
1	Pump body	Stainless steel	EN 10213-4-GX5CrNiMo19-11-2 (1.4408)	ASTM CF8M (AISI 316)
1A	Lower support	Stainless steel	EN 10213-4-GX5CrNiMo19-11-2 (1.4408)	ASTM CF8M (AISI 316)
2-3	Impeller, Diffuser	Stainless steel	EN 10213-4-GX5CrNiMo19-11-2 (1.4408)	ASTM CF8M (AISI 316)
4	Outer sleeve	Stainless steel	EN 10088-1-X2CrNiMo17-12-2 (1.4404)	AISI 316L
5	Shaft	Duplex stainless steel	EN 10088-1-X2CrNiMoN22-5-3 (1.4462)	UNS S 31803
6	Adapter	Cast iron	EN 1561-GJL-200 (JL1030)	ASTM Class 25
6	Adapter	Cast iron	EN 1563-GJS-500-7 (JS1050)	
7	Wear ring	Technopolymer PPS		
8	Coupling	Cast iron	EN 1561-GJL-200 (JL1030)	ASTM Class 25
8	Coupling	Cast iron	EN 1563-GJS-500-7 (JS1050)	
9-9A	Upper head, Seal housing	Stainless steel	EN 10213-4-GX5CrNiMo19-11-2 (1.4408)	ASTM CF8M (AISI 316)
10	Mechanical seal	Silicon carbide / Carbon / EPDM		
11	Elastomers	EPDM		
12	Coupling protection	Stainless steel	EN 10088-1-X5CrNi18-10 (1.4301)	AISI 304
13	Shaft sleeve and bushing	Tungsten carbide		
14	Bushing for diffuser	Carbon		
15	Fill / drain / air plugs	Stainless steel	EN 10088-1-X5CrNiMo17-12-2 (1.4401)	AISI 316
16	Tie rods	Stainless steel	EN 10088-1-X17CrNi16-2 (1.4057)	AISI 431
17	Adapter ring	Stainless steel	EN 10213-4-GX5CrNiMo19-11-2 (1.4408)	ASTM CF8M (AISI 316)

125sv-n-en_a_tm

**e-SV™ SERIES
MECHANICAL SEALS, ACCORDING TO EN 12756**

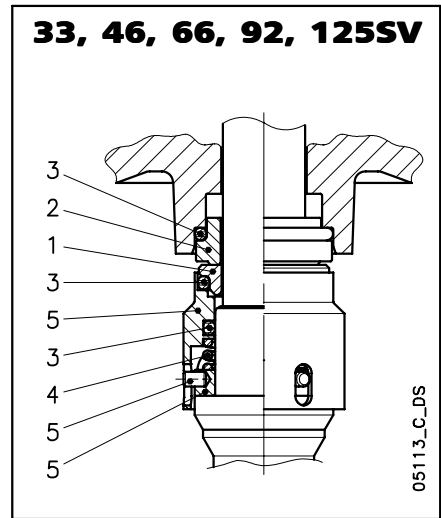
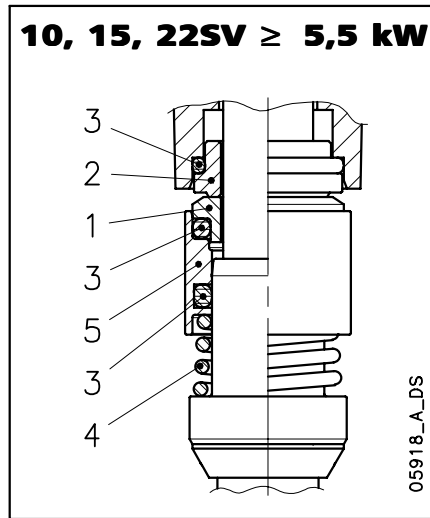
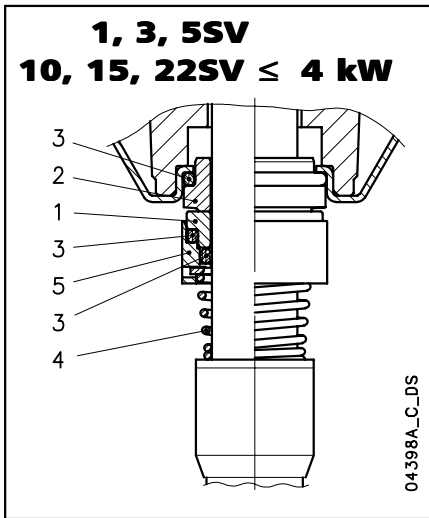

LIST OF MATERIALS

POSITION 1 - 2	POSITION 3	POSITION 4 - 5
Q ₁ : Silicon Carbide	E : EPDM	G : AISI 316
B : Resin impregnated carbon	V : FPM	
C : Special resin impregnated carbon	T : PTFE	

TYPE OF SEAL

sv_ten-mec-en_a_tm

TYPE	POSITION					TEMPERATURE (°C)
	1 ROTATING PART	2 STATIONARY PART	3 ELASTOMERS	4 SPRINGS	5 OTHER COMPONENTS	
STANDARD MECHANICAL SEAL						
Q ₁ B E G G	Q ₁	B	E	G	G	-30 +120
OTHER TYPES OF AVAILABLE MECHANICAL SEAL						
Q ₁ Q ₁ E G G	Q ₁	Q ₁	E	G	G	-30 +120
Q ₁ B V G G	Q ₁	B	V	G	G	-10 +120
Q ₁ Q ₁ V G G	Q ₁	Q ₁	V	G	G	-10 +120
*Q ₁ C T G G	Q ₁	C	T	G	G	0 +120
*Q ₁ Q ₁ T G G	Q ₁	Q ₁	T	G	G	0 +120

* Versions with anti-rotation lock pin of the fixed part.

sv_tipi-ten-mec-en_b_tc

**PRESSURE/TEMPERATURE APPLICATION LIMITS FOR COMPLETE PUMP
(APPLICABLE WITH ANY OF THE SEALS LISTED ABOVE)**

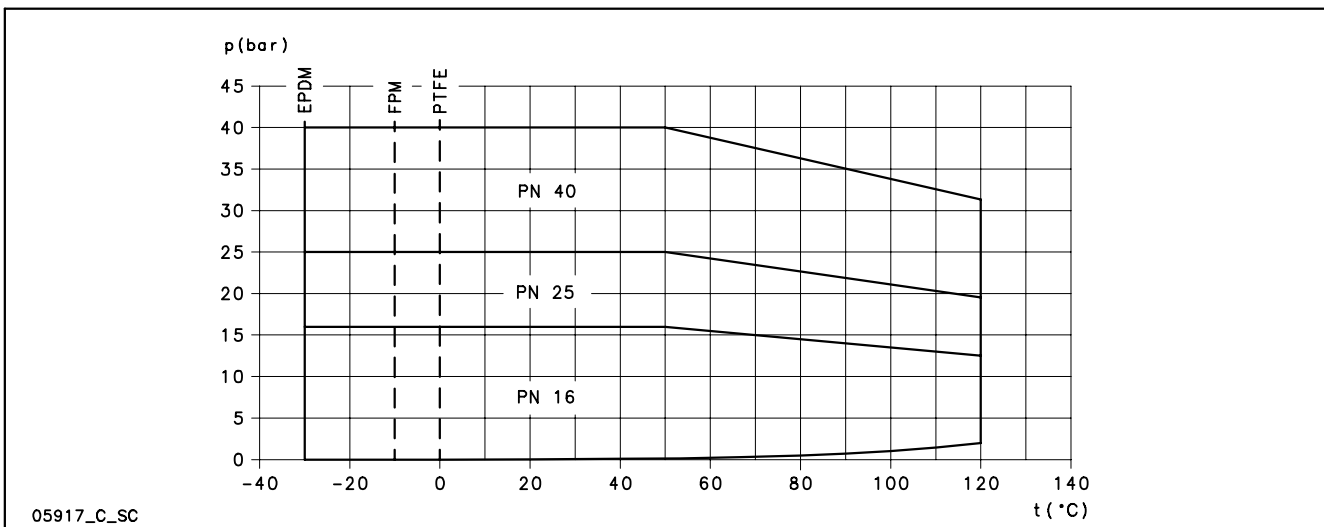

COMPATIBILITY CHART FOR MATERIALS IN CONTACT WITH MOST COMMONLY USED LIQUIDS

LIQUID	CONCENTRATION (%)	TEMPERAT. MIN/MAX (°C)	SPECIF. WEIGHT (Kg/dm ³)	1, 3, 5, 10, 15, 22 SV		33, 46, 66, 92, 125 SV		RECOMMEND. SEAL	ELASTOM.
				VERSION Standard	VERSION N	VERSION Standard	VERSION N		
Acetic acid	80	-10 +70	1,05	•	•		•	Q ₁ BEGG	E
Alkaline degreaser	5	80		•	•	•	•	Q ₁ Q ₁ VGG	V
Aluminium sulfate	30	-5 +50	2,71		•		•	Q ₁ Q ₁ EGG	E
Ammonia in water	25	-20 +50	0,99	•	•		•	Q ₁ BEGG	E
Ammonium sulfate	10	-10 +60	1,77		•		•	Q ₁ Q ₁ EGG	E
Benzoic acid	70	0 +70	1,31	•	•		•	Q ₁ BVGG	V
Boric acid	saturated	-10 +90	1,43	•	•		•	Q ₁ Q ₁ VGG	V
Butyl alcohol	100	-5 +80	0,81	•	•	•	•	Q ₁ BVGG	V
Caustic soda	25	0 +70	2,13	•	•	•	•	Q ₁ Q ₁ EGG	E
Chloroform	100	-10 +30	1,48	•	•	•	•	Q ₁ BVGG	V
Citric acid	5	-10 +70	1,54	•	•		•	Q ₁ BEGG	E
Cleaning products	10	-5 +100		•	•	•	•	Q ₁ Q ₁ VGG	V
Copper sulfate	20	0 +30	2,28		•		•	Q ₁ Q ₁ VGG	V
Cutting fluid	100	-5 +110	0,90	•	•	•	•	Q ₁ BVGG	V
Deionised, demineralised water	100	-25 +110	1	•	•	•	•	Q ₁ BEGG	E
Denatured alcohol	100	-5 +70	0,81	•	•	•	•	Q ₁ BEGG	E
Diathermic oil	100	-5 +110	0,90	•	•	•	•	Q ₁ BVGG	V
Emulsion oil and water	any	-5 +90		•	•	•	•	Q ₁ BVGG	V
Ethyl alcohol	100	-5 +40	0,81	•	•	•	•	Q ₁ BEGG	E
Ethylene glycol	30	-30 +120			•		•	Q ₁ BEGG	E
Formaldehyde	100	0 +30	1,13	•	•	•	•	Q ₁ Q ₁ TGG	T
Formic acid	5	-15 +25	1,22	•	•		•	Q ₁ BEGG	E
Glycerine	100	+20 +90	1,26	•	•	•	•	Q ₁ BEGG	E
Hydraulic oil	100	-5 +110		•	•	•	•	Q ₁ BVGG	V
Hydrochloric acid	2	-5 +25	1,20		•		•	Q ₁ Q ₁ VGG	V
Hydroxide sodium	25	0 +70		•	•	•	•	Q ₁ Q ₁ EGG	E
Iron sulfate	10	-5 +30	2,09		•		•	Q ₁ BEGG	E
Methyl alcohol	100	-5 +40	0,79	•	•	•	•	Q ₁ BEGG	E
Mineral oil	100	-5 +110	0,94	•	•	•	•	Q ₁ BVGG	V
Nitric acid	50	-5 +30	1,48	•	•		•	Q ₁ Q ₁ VGG	V
Perchloroethylene	100	-10 +30	1,60	•	•	•	•	Q ₁ BVGG	V
Phosphates-polyphosphates	10	-5 +90			•		•	Q ₁ Q ₁ VGG	V
Phosphoric acid	10	-5 +30	1,33		•		•	Q ₁ BEGG	E
Propyl alcohol (Propanol)	100	-5 +80	0,80	•	•	•	•	Q ₁ BEGG	E
Propylene glycol	30	-30 +120		•	•	•	•	Q ₁ BEGG	E
Sodium bicarbonate (Baking soda)	saturated				•		•	Q ₁ BEGG	E
Sodium hypochlorite	1	-10 +25			•		•	Q ₁ Q ₁ VGG	V
Sodium nitrate	saturated	-10 +80	2,25	•	•	•	•	Q ₁ BEGG	E
Sodium sulfate	15	-10 +40	2,60	•	•	•	•	Q ₁ Q ₁ EGG	E
Sulphuric acid	2	-10 +25	1,84		•		•	Q ₁ BVGG	V
Tannic acid	20	0 +50			•		•	Q ₁ BEGG	E
Tartaric acid	50	-10 +25	1,76	•	•		•	Q ₁ Q ₁ VGG	V
Trichloroethylene	100	-10 +40	1,46	•	•	•	•	Q ₁ BVGG	V
Uric acid	80	-10 +80	1,89	•	•		•	Q ₁ BEGG	E
Vegetable oil	100	-5 +110	0,95	•	•	•	•	Q ₁ BEGG	E
Water	100	-5 +120		•	•	•	•	Q ₁ BEGG	E
Water condensate	100	-5 +100	1	•	•	•	•	Q ₁ BEGG	E
Water detergents, mineral oils mixture	10	-5 +80		•	•	•	•	Q ₁ Q ₁ VGG	V

tab-comp-sv-en_b_tm

The above table indicates the compatibility of materials depending on the pumped liquid. Check the specific weight of the liquid or the viscosity as this could affect the power input of the motor and hydraulic performance. For further details, please contact the sales network.

HIGH PRESSURE (50/60 Hz)

e-SV™ SERIES - HIGH PRESSURE 50/60 Hz

Background and context

In the water treatment industry (Ultra or Nano filtration, reverse osmosis) in the washing and cleaning industry (High pressure washdown systems) or with boiler-feed application, high pressure is mandatory to ensure consistency in the performance of the systems. Therefore Lowara has developed e-SV™ High Pressure: a wide range of pumps and pump systems able to deliver robust and durable performances up to 45 bar.

Benefits of e-SV™ HIGH PRESSURE

Versatile range: e-SV™ High pressure is available in two different configurations: single pump solution or tandem pump solution (two pumps in series). If the inlet pressure value is already high, Lowara delivers a single pump able to withstand the high inlet pressure and deliver up to 45 bar pressure at the outlet. With applications where the high pressure has to be delivered starting from atmospheric pressure in the inlet, Lowara delivers the tandem solution able to deliver up to 45 bar pressure at the outlet of the system.

Long lasting performances: e-SV™ High Pressure benefits of a particular design of the sleeve to withstand the pressure without any limitation in the inlet pressure but maximum 45 bar measured at the outlet. The specific balanced mechanical seal and the balanced design of the impeller and the hard material intermediate bush bearing allows e-SV™ withstanding up to 45 bar without stressing the motor and the pump components, with a direct consequence on the reduction of the life cycle cost.

Easy installation and maintenance: e-SV™ High Pressure in tandem system is composed of two identical standard e-SV™ High Pressure pumps making replacement easy and cost-effective. e-SV™ High Pressure in tandem has to be ordered as two single e-SV™ High Pressure pumps together with the specific accessories for the installation (see specific accessories section).

Code identification

e-SV™ High Pressure design is identified with a "P" in the product codification of the whole e-SV™ range.

Example: 3SV13P015T

P = High Pressure version.

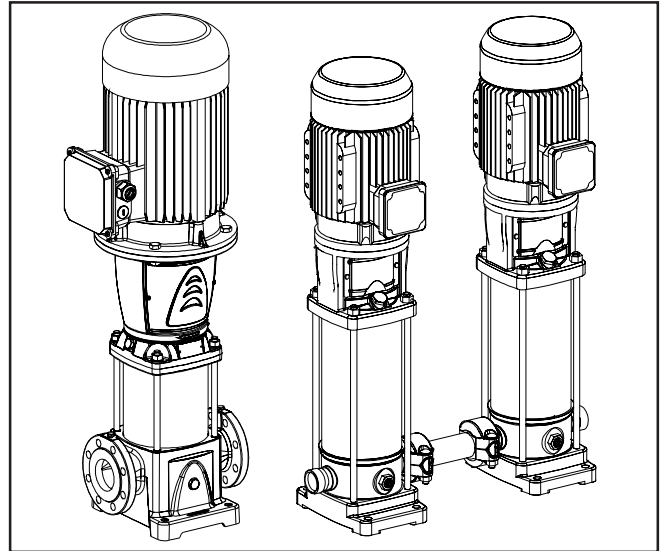

Special features / product benefits

- **Double sleeve design** to withstand high pressure up to 45 bar.
- **Balanced standard mechanical seal** (EN12756) on all models. **Easy to replace, without removing the motor** from 5,5 kW.
- **Hard material intermediate bush bearing** (Tungsten Carbide) to withstand heavy duty applications.
- **Balanced impeller design** to reduce axial thrust for longer standard motor bearing life.
- Wide range of size to cover all requested duty points: from 1SV to 125SV.
- **IE2/IE3 standard motors**, 3-phase, 2-poles from 0,75 kW to 55 kW with blocked bearing **to support maximum thrust without limiting inlet pressure.**
- **i-Alert device** to reduce life cycle costs by increasing Mean time between Failures (MTBF).

Special configurations

e-SV™ High Pressure offers a wide range of configurations:

- Material execution. See Material section.
- Mechanical seal and rubbers options. See Mechanical seal and rubber section.
- Motors options and configuration. See Motor section.
- Hydrovar® drive fitted. See e-SVH – Hydrovar® fitted section.

e-SV™ SERIES - HIGH PRESSURE 50/60 Hz

Technical characteristics - Design

- 1: Double sleeve design for optimized resistance to pressure up to 45 bar.
- 2: Balanced mechanical seal to withstand high pressure.

Operating characteristics for single pump

For the hydraulic performances of the single pump, please refer to the standard catalogue of e-SV™.

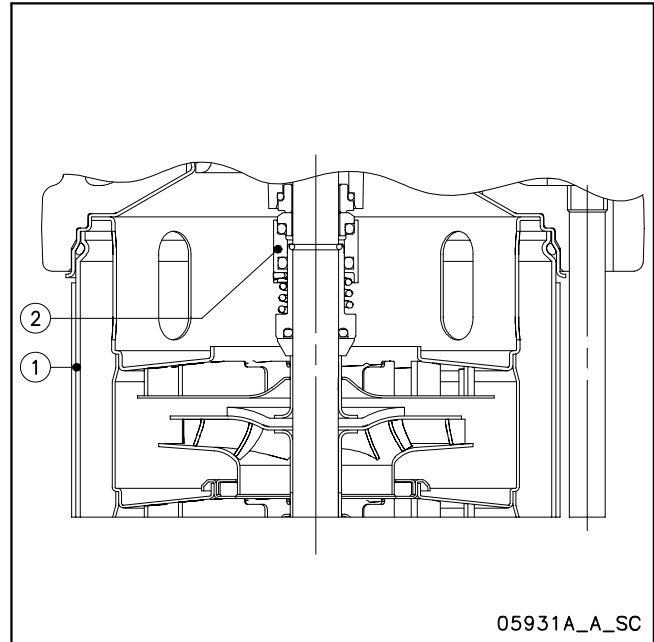

**HIGH
PRESSURE**

TECHNICAL CHARACTERISTICS

P VERSIONS - 50 Hz	1SV	3SV	5SV	10SV	15SV	22SV	33SV	46SV	66SV	92SV	125SV
Max efficiency flow (m³/h)	1,7	3	5,5	10,5	16,5	20,5	31	43	72	90	120
Flow range (m³/h)	0,7÷2,4	1,2÷4,4	2,4÷8,5	5÷14	8÷24	11÷29	15÷40	22÷60	30÷85	45÷120	60÷160
Maximum pressure (bar)	45	44	45	45	45	43	45	45	45	43	37
Motor power (kW)	0,37÷2,2	0,37÷3	0,37÷5,5	0,75÷11	1,1÷15	1,1÷18,5	2,2÷30	3÷45	4÷45	5,5÷45	7,5÷55
Max η (%) of pump	50	60	70	71	72	73	77	79	78	80	78
Standard temperature of pumped liquid (°C)	-30 +120										
Standard ambient temp. (°C)	-15 +40										
Inlet min. pressure (bar)	No minimum inlet pressure required with Lowara motors										
Material execution	No variation according to e-SV N version (AISI 316)										
Mechanical seal configuration	Balanced mechanical seal. Standard materials: Silicon Carbide / Carbon / EPDM										
Flange configuration	Victaulic® coupling (1, 3, 5, 10, 15, 22SV versions) Round flange (33, 46, 66, 92, 125SV versions)										

svp-50-en_a_tg

P VERSIONS - 60 Hz	1SV	3SV	5SV	10SV	15SV	22SV	33SV	46SV	66SV	92SV	125SV
Max efficiency flow (m³/h)	2	3,6	7	12,4	21,8	24,5	40	50	87	108	144
Flow range (m³/h)	0,8÷2,8	1,4÷5,2	3÷10	6÷17	10÷29	13÷34	18÷48	27÷72	36÷102	54÷144	60÷160
Maximum pressure (bar)	45	44	45	45	45	45	45	45	43	33	36
Motor power (kW)	0,37÷3	0,37÷4	0,55÷5,5	0,75÷11	1,5÷18,5	2,2÷18,5	3÷37	5,5÷45	7,5÷45	11÷45	15÷55
Max η (%) of pump	50	60	70	71	72	73	77	79	78	80	78
Standard temperature of pumped liquid (°C)	-30 +120										
Standard ambient temp. (°C)	-15 +40										
Inlet min. pressure (bar)	No minimum inlet pressure required with Lowara motors										
Material execution	No variation according to e-SV N version (AISI 316)										
Mechanical seal configuration	Balanced mechanical seal. Standard materials: Silicon Carbide / Carbon / EPDM										
Flange configuration	Victaulic® coupling (1, 3, 5, 10, 15, 22SV versions) Round flange (33, 46, 66, 92, 125SV versions)										

svp-60-en_a_tg

e-SV™ SERIES - HIGH PRESSURE BALANCED MECHANICAL SEALS, ACCORDING TO EN 12756

**HIGH
PRESSURE**

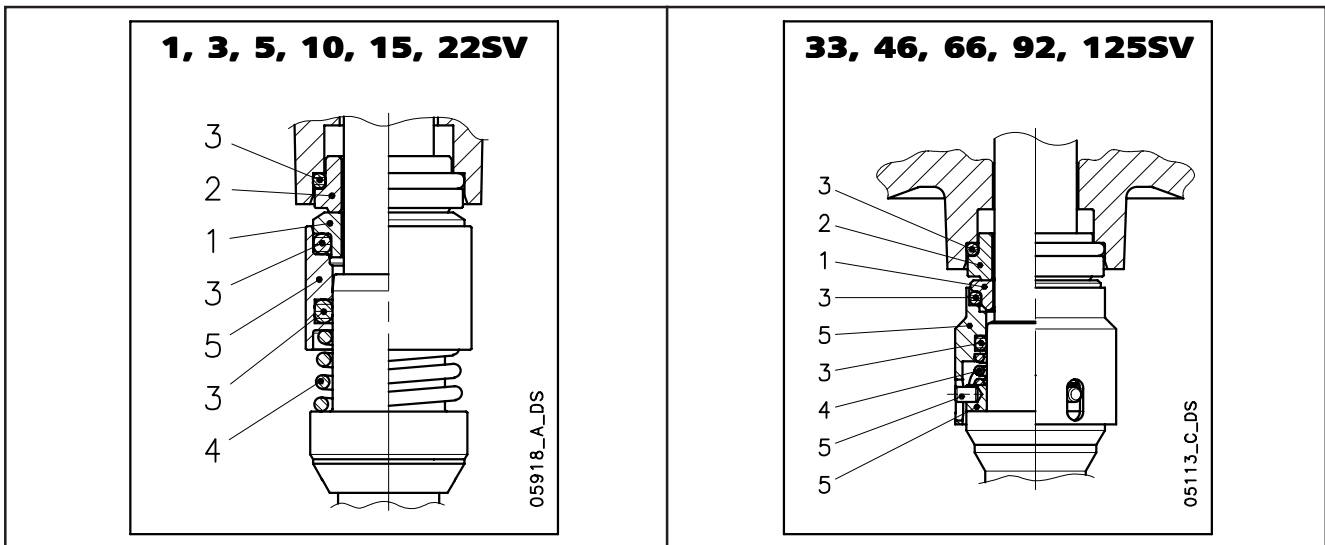

LIST OF MATERIALS

POSITION 1 - 2	POSITION 3	POSITION 4 - 5
Q ₁ : Silicon Carbide	E : EPDM	G : AISI 316
B : Resin impregnated carbon	V : FPM	

TYPE OF SEAL

1-125sv-p_ten-mec-en_a_tm

TYPE	POSITION					TEMPERATURE (°C)
	1 ROTATING PART	2 STATIONARY PART	3 ELASTOMERS	4 SPRINGS	5 OTHER COMPONENTS	
STANDARD MECHANICAL SEAL						
Q ₁ B E G G	Q ₁	B	E	G	G	-30 +120
OTHER TYPES OF AVAILABLE MECHANICAL SEAL						
Q ₁ Q ₁ E G G	Q ₁	Q ₁	E	G	G	-30 +120
Q ₁ B V G G	Q ₁	B	V	G	G	-10 +120
Q ₁ Q ₁ V G G	Q ₁	Q ₁	V	G	G	-10 +120

1-125sv-p_tipi-ten-mec-en_a_tc

PRESSURE/TEMPERATURE APPLICATION LIMITS FOR COMPLETE PUMP (APPLICABLE WITH ANY OF THE SEALS LISTED ABOVE)

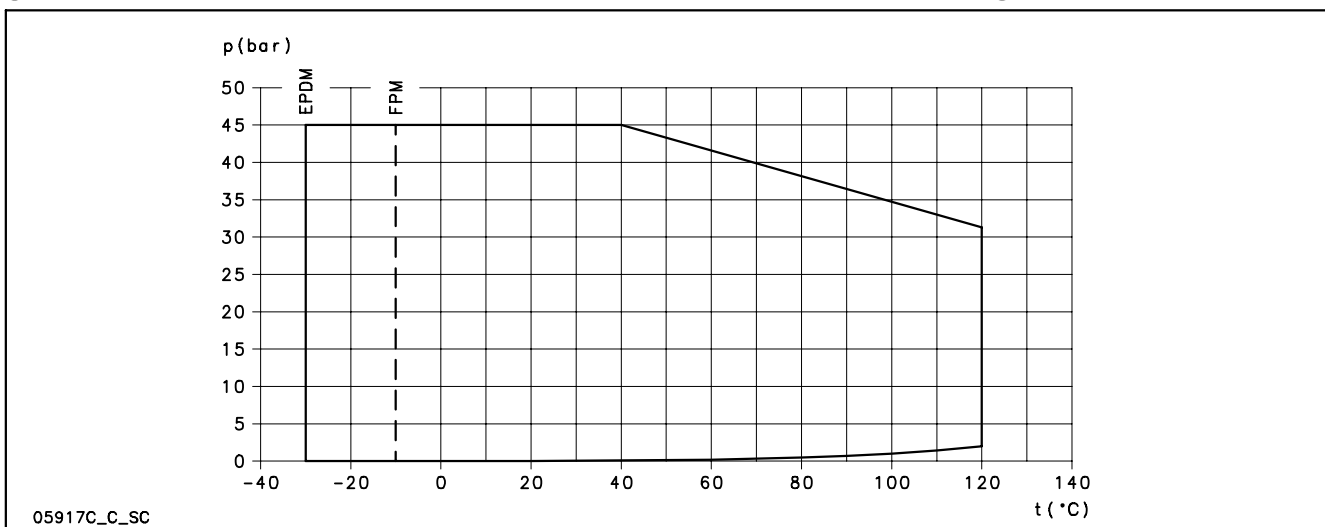

05917C_C_SC

**SV..P SERIES - HIGH PRESSURE
HYDRAULIC PERFORMANCE RANGE AT 50 Hz**

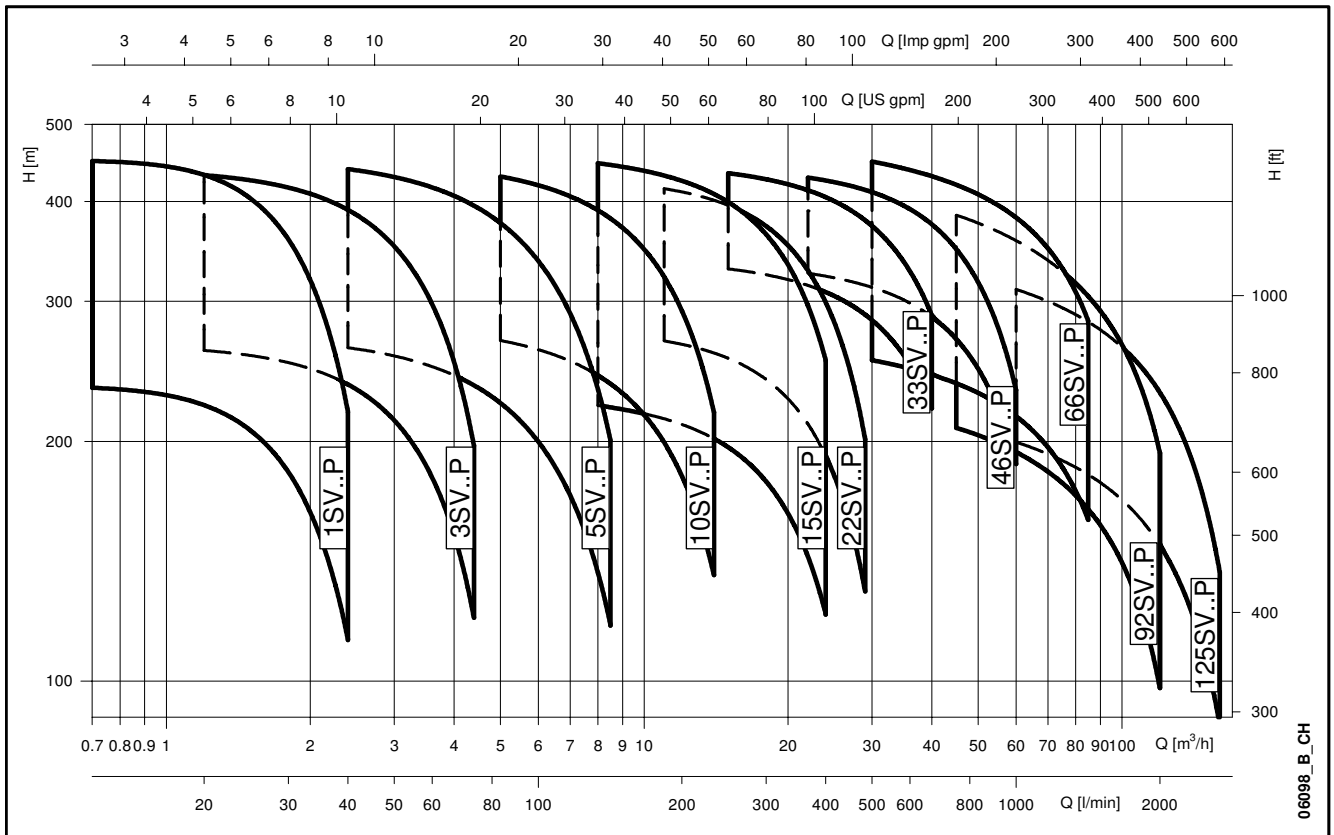

**HIGH
PRESSURE**

**SV..P SERIES - HIGH PRESSURE
HYDRAULIC PERFORMANCE RANGE AT 60 Hz**

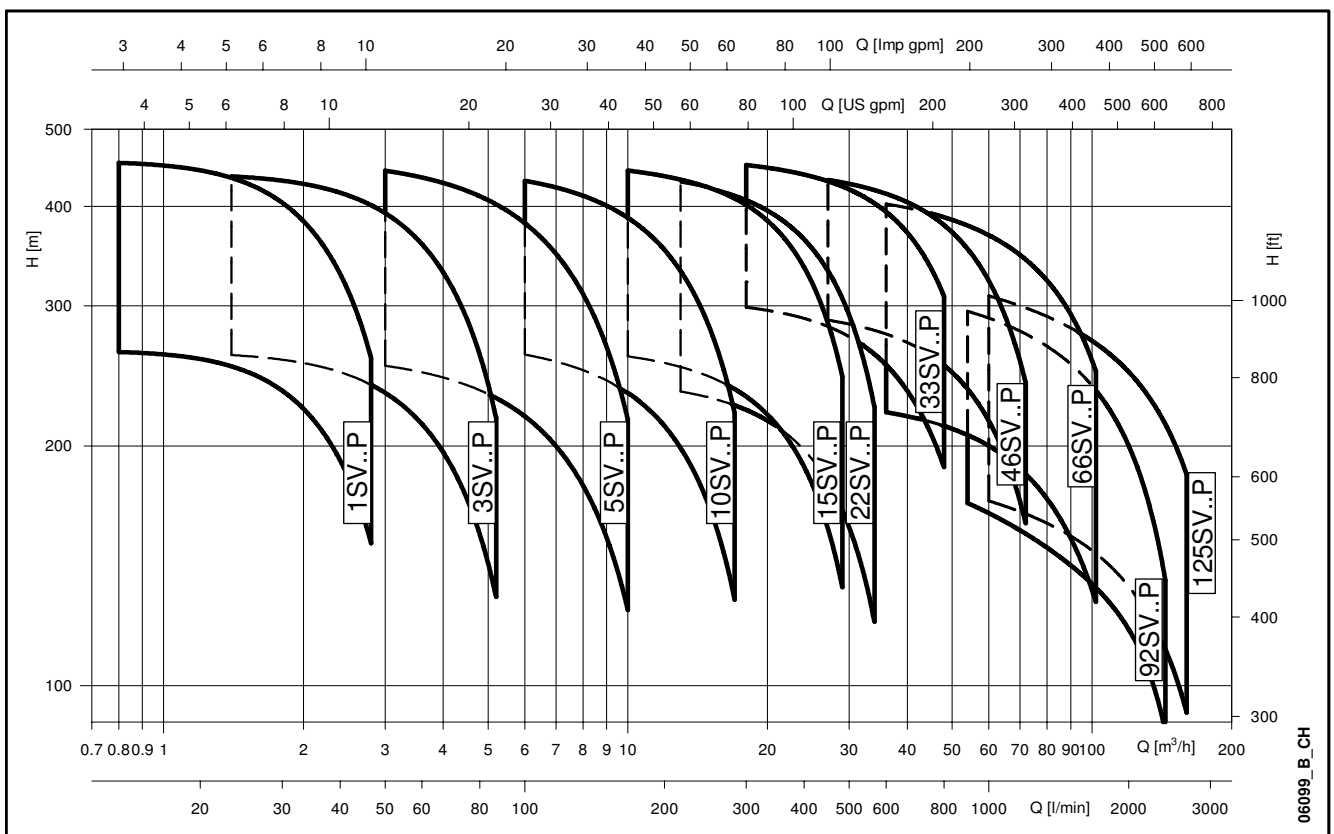

1SV..P SERIES - HIGH PRESSURE DIMENSIONS AND WEIGHTS AT 50 Hz, 2-POLE

HIGH PRESSURE 50HZ

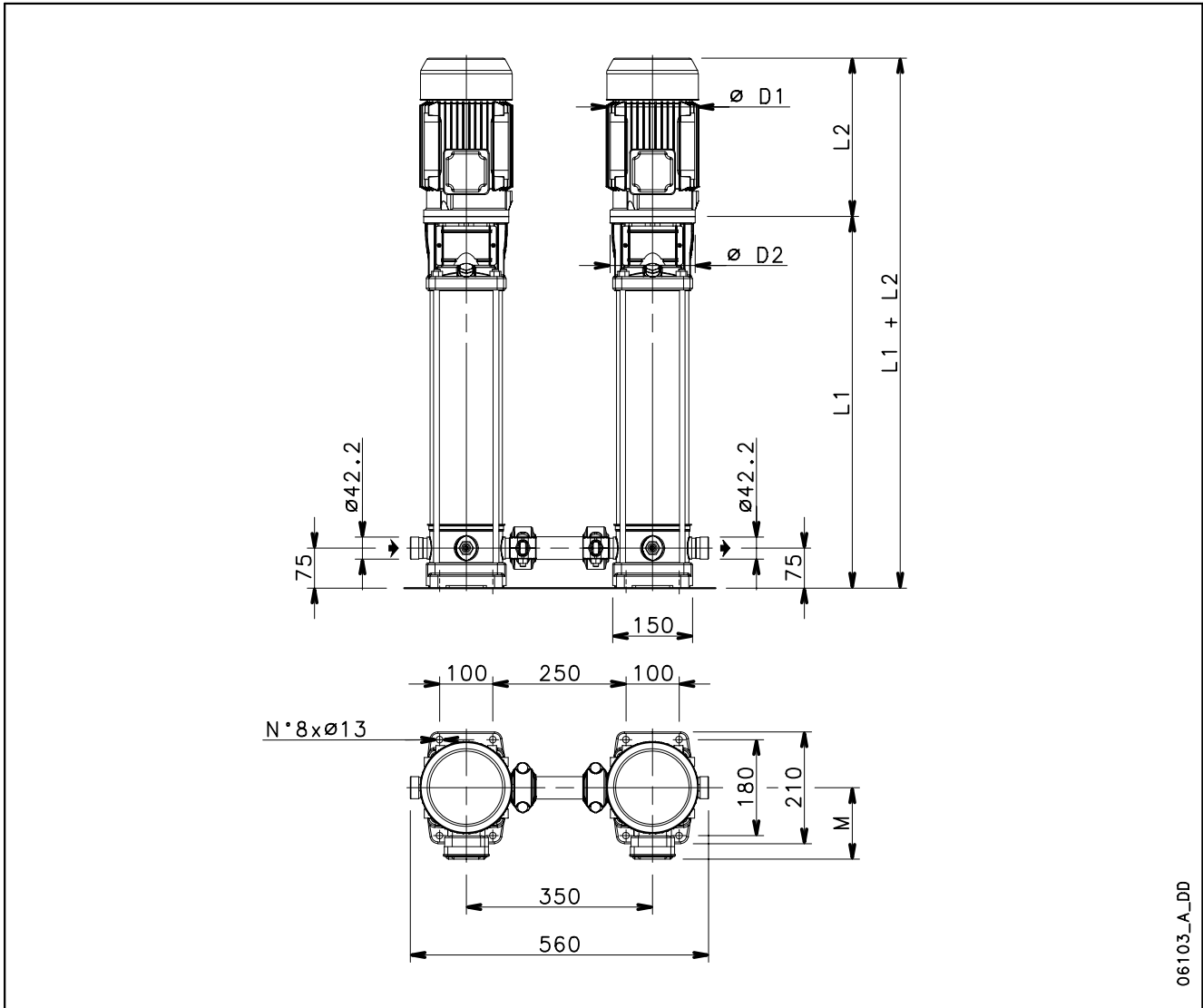

06103_A_DD

PUMP TYPE	MOTOR		DIMENSIONS (mm)					WEIGHT (Kg)	
	kW	Size	L1	L2	M	D1	D2	PUMP	ELECTRIC PUMP
1SV19P../D	1,1	80	628	263	129	155	120	17,5	29,1
1SV22P../D	1,1	80	688	263	129	155	120	19	30,6
1SV25P../D	1,5	90	758	263	129	155	140	21,2	34,2
1SV27P../D	1,5	90	798	263	129	155	140	22,2	35,2
1SV30P../D	1,5	90	858	263	129	155	140	23,6	36,6
1SV32P..	2,2	90	898	298	134	174	140	24,6	42,8
1SV34P..	2,2	90	938	298	134	174	140	25,6	43,8
1SV37P..	2,2	90	998	298	134	174	140	27	45,2

Dimensions and weights are related to one electric pump.

1sv-p-2p50-en_b_td

1SV..P SERIES - HIGH PRESSURE OPERATING CHARACTERISTICS AT 50 Hz, 2-POLE

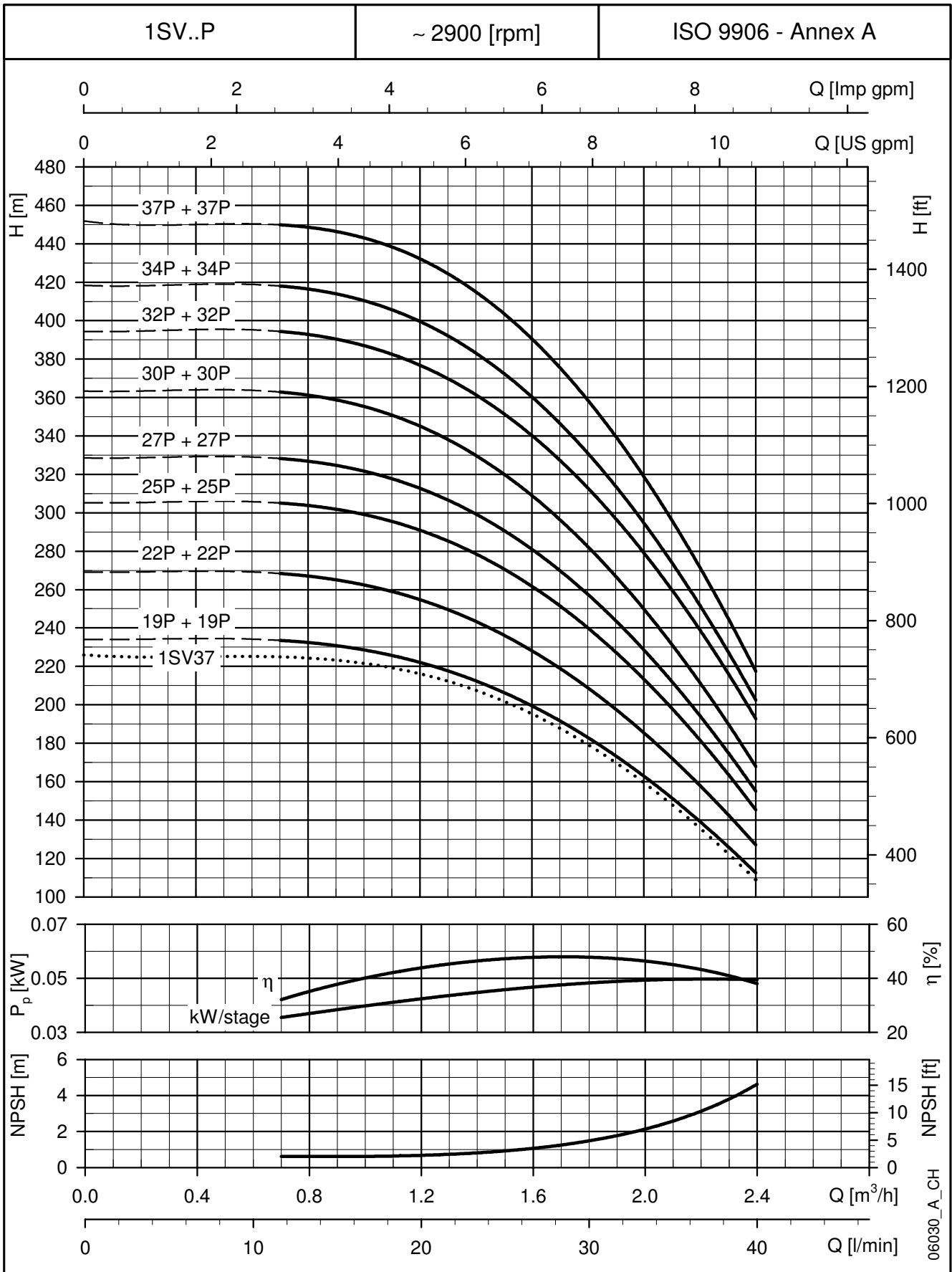

HIGH PRESSURE 50HZ

These performances are valid for liquids with density $\rho = 1.0 \text{ Kg/dm}^3$ and kinematic viscosity $\nu = 1 \text{ mm}^2/\text{sec}$.

**3SV..P SERIES - HIGH PRESSURE
DIMENSIONS AND WEIGHTS AT 50 Hz, 2-POLE**

**HIGH
PRESSURE
50Hz**

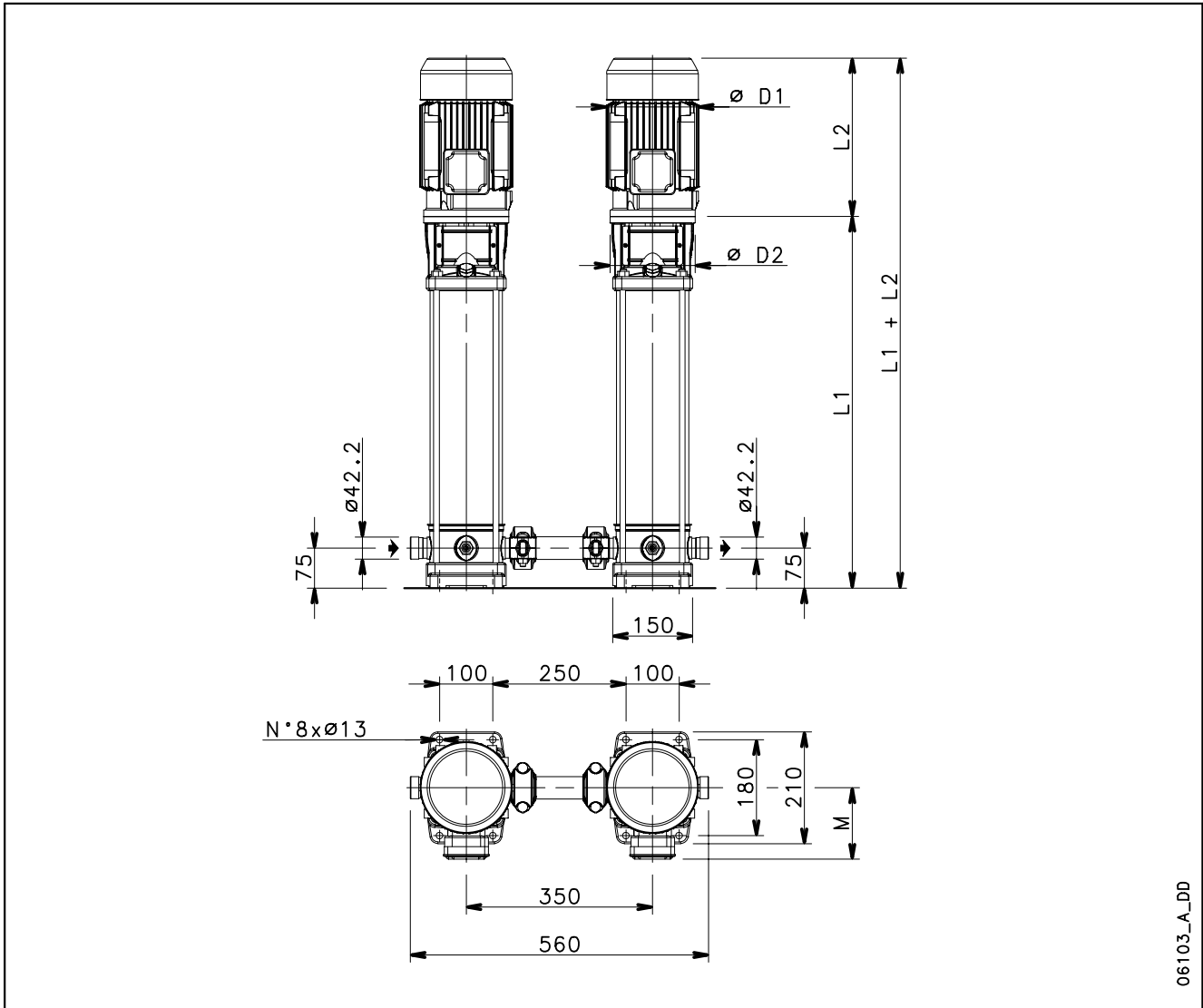

PUMP TYPE	MOTOR		DIMENSIONS (mm)					WEIGHT (Kg)	
	kW	Size	L1	L2	M	D1	D2	PUMP	ELECTRIC PUMP
3SV16P../D	1,5	90	578	263	129	155	140	17	
3SV19P..	2,2	90	638	298	134	174	140	18,4	36,6
3SV21P..	2,2	90	678	298	134	174	140	19,4	37,6
3SV23P..	2,2	90	718	298	134	174	140	20,3	38,5
3SV25P..	2,2	90	758	298	134	174	140	21,4	39,6
3SV27P..	3	100	808	298	134	174	160	23,4	44,4
3SV29P..	3	100	848	298	134	174	160	24,3	45,3

Dimensions and weights are related to one electric pump.

3sv-p-2p50-en_c_td

3SV..P SERIES - HIGH PRESSURE OPERATING CHARACTERISTICS AT 50 Hz, 2-POLE

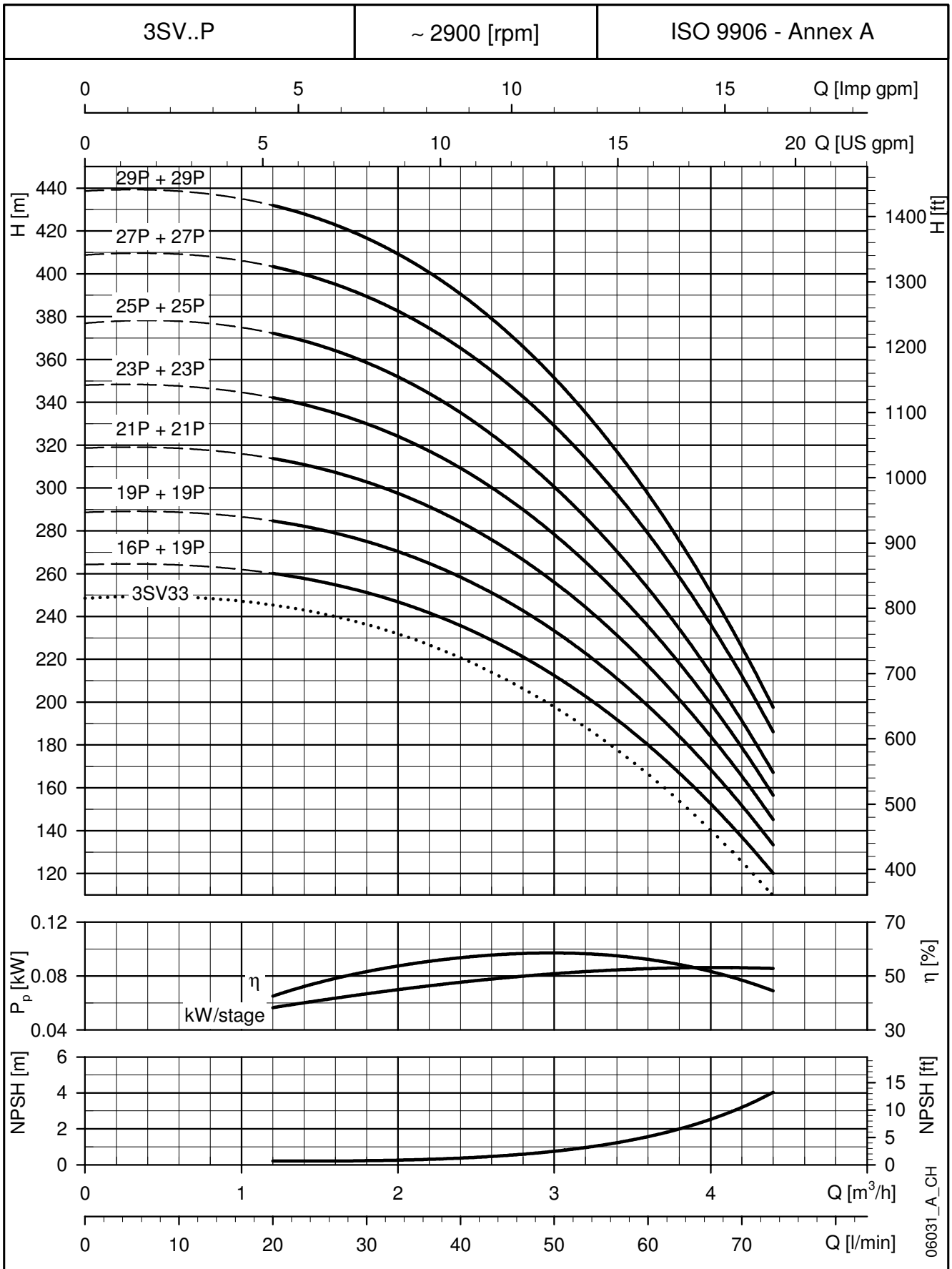

HIGH PRESSURE 50HZ

06031_A_CH

These performances are valid for liquids with density $\rho = 1.0 \text{ Kg/dm}^3$ and kinematic viscosity $\nu = 1 \text{ mm}^2/\text{sec}$.

5SV..P SERIES - HIGH PRESSURE DIMENSIONS AND WEIGHTS AT 50 Hz, 2-POLE

HIGH PRESSURE 50Hz

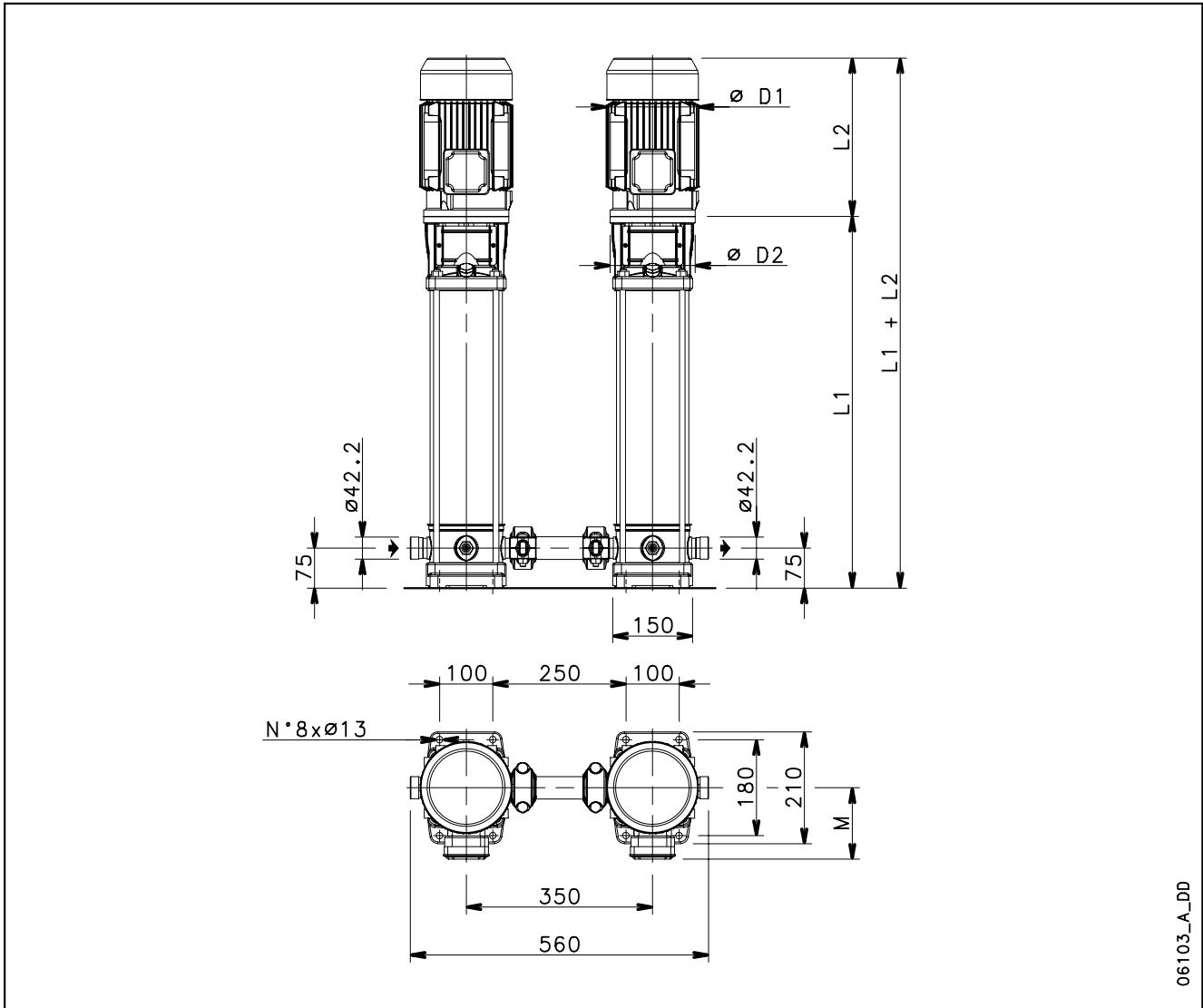

06103_A_DD

PUMP TYPE	MOTOR		DIMENSIONS (mm)					WEIGHT (Kg)	
	kW	Size	L1	L2	M	D1	D2	PUMP	ELECTRIC PUMP
5SV18P..	3	100	723	298	134	174	160	20,4	41,4
5SV21P..	3	100	798	298	134	174	160	22,1	43,1
5SV23P..	4	112	848	319	154	197	160	23,3	49,7
5SV25P..	4	112	898	319	154	197	160	24,4	50,8
5SV28P..	4	112	973	319	154	197	160	26,4	52,8
5SV30P..	5,5	132	1043	375	168	214	300	31,7	69,3

Dimensions and weights are related to one electric pump.

5sv-p-2p50-en_c_td

**5SV..P SERIES - HIGH PRESSURE
OPERATING CHARACTERISTICS AT 50 Hz, 2-POLE**

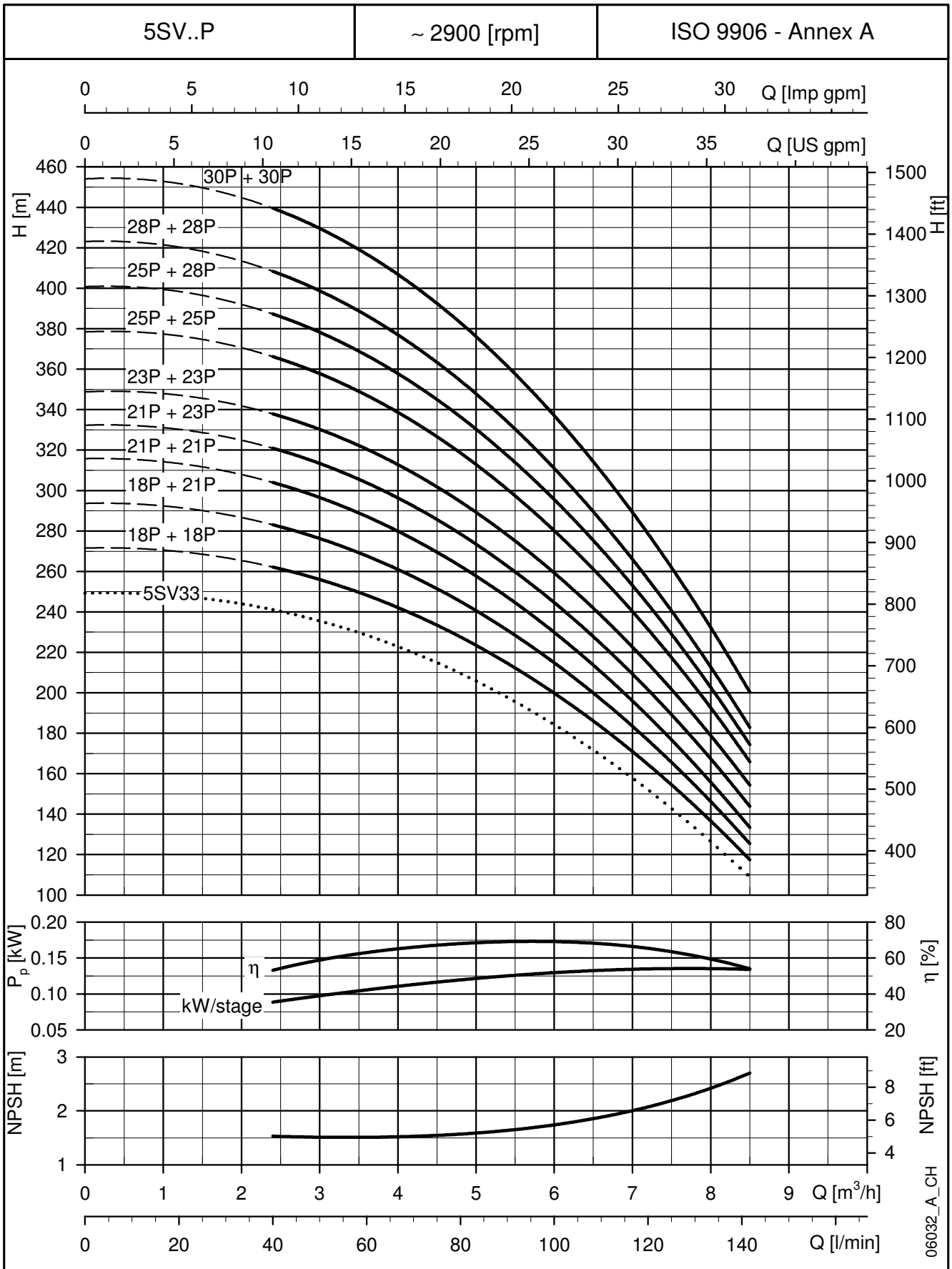

HIGH PRESSURE 50HZ

These performances are valid for liquids with density $\rho = 1.0 \text{ Kg/dm}^3$ and kinematic viscosity $\nu = 1 \text{ mm}^2/\text{sec}$.

10SV..P SERIES - HIGH PRESSURE DIMENSIONS AND WEIGHTS AT 50 Hz, 2-POLE

HIGH PRESSURE 50Hz

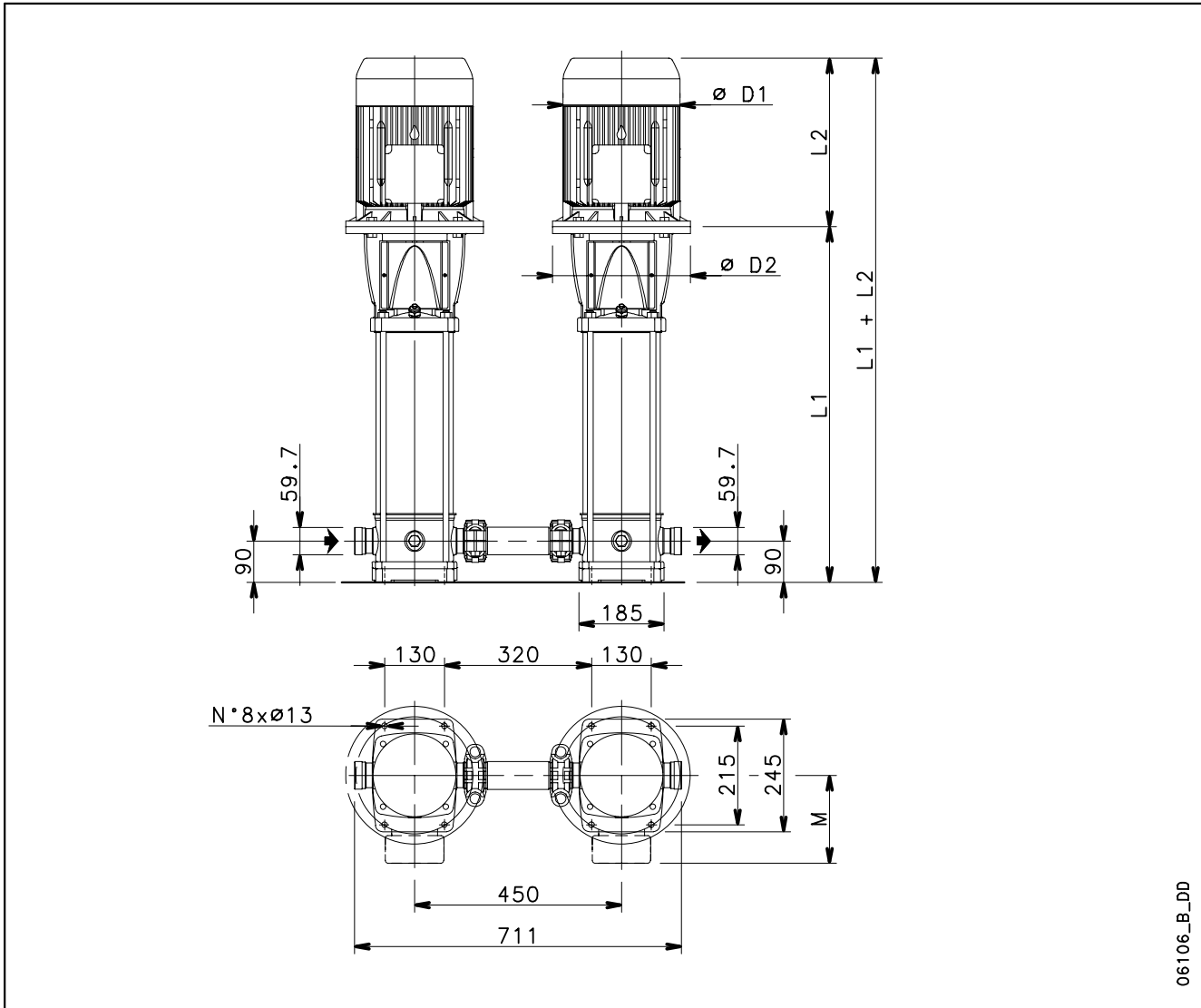

06106_B_DD

PUMP TYPE	MOTOR		DIMENSIONS (mm)					WEIGHT (Kg)	
	kW	Size	L1	L2	M	D1	D2	PUMP	ELECTRIC PUMP
10SV11P..	4	112	675	319	154	197	160	27,5	54
10SV13P..	5,5	132	806	375	168	214	300	35,8	74
10SV15P..	5,5	132	870	375	168	214	300	38,1	76
10SV17P..	7,5	132	934	367	191	256	300	40,4	97
10SV18P..	7,5	132	966	367	191	256	300	41,5	98
10SV20P..	7,5	132	1030	367	191	256	300	43,8	100

Dimensions and weights are related to one electric pump.

10sv-p-2p50-en_c_td

**10SV..P SERIES - HIGH PRESSURE
OPERATING CHARACTERISTICS AT 50 Hz, 2-POLE**

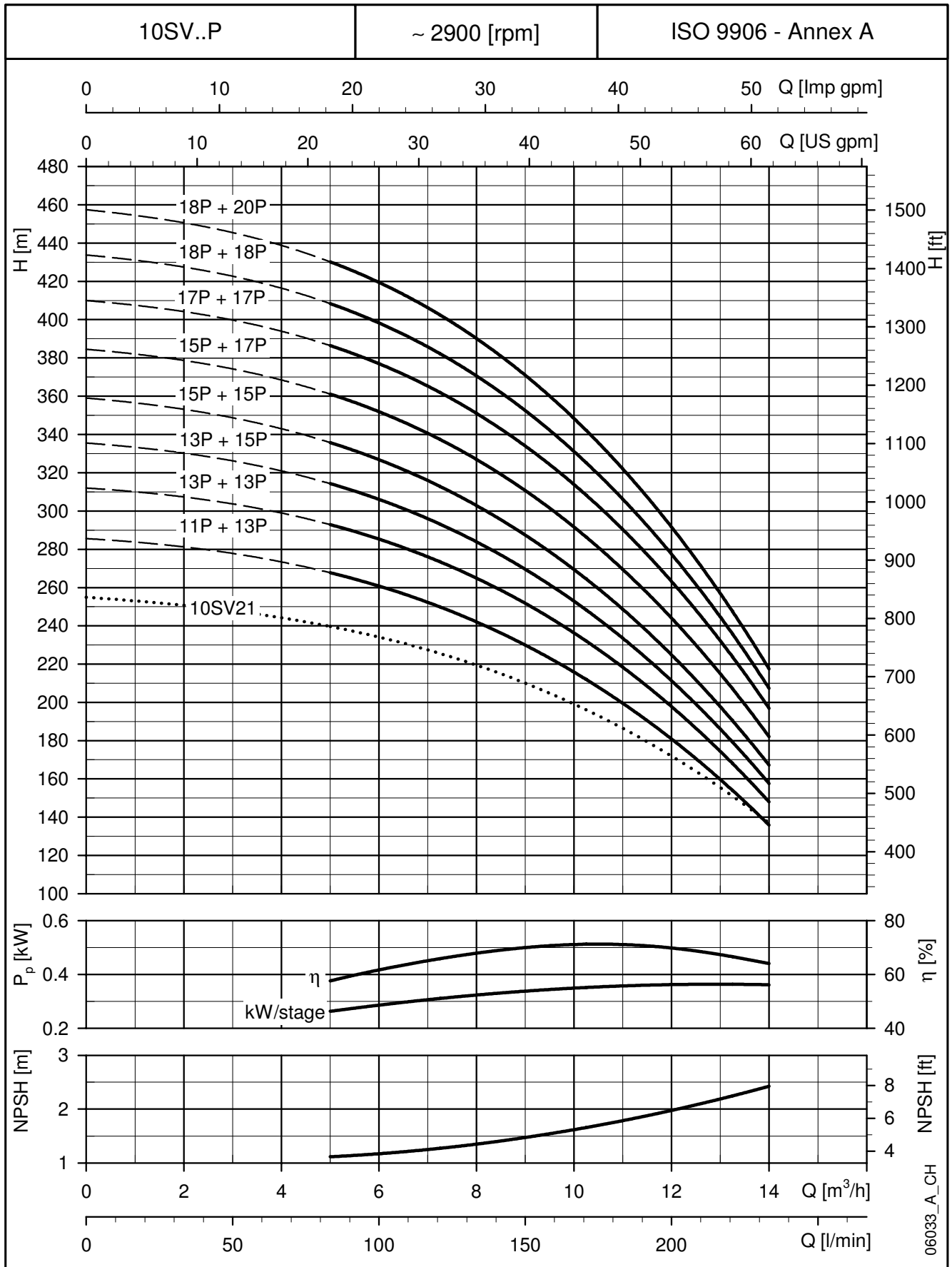

HIGH PRESSURE 50HZ

These performances are valid for liquids with density $\rho = 1.0 \text{ Kg/dm}^3$ and kinematic viscosity $\nu = 1 \text{ mm}^2/\text{sec}$.

15SV..P SERIES - HIGH PRESSURE DIMENSIONS AND WEIGHTS AT 50 Hz, 2-POLE

HIGH PRESSURE 50Hz

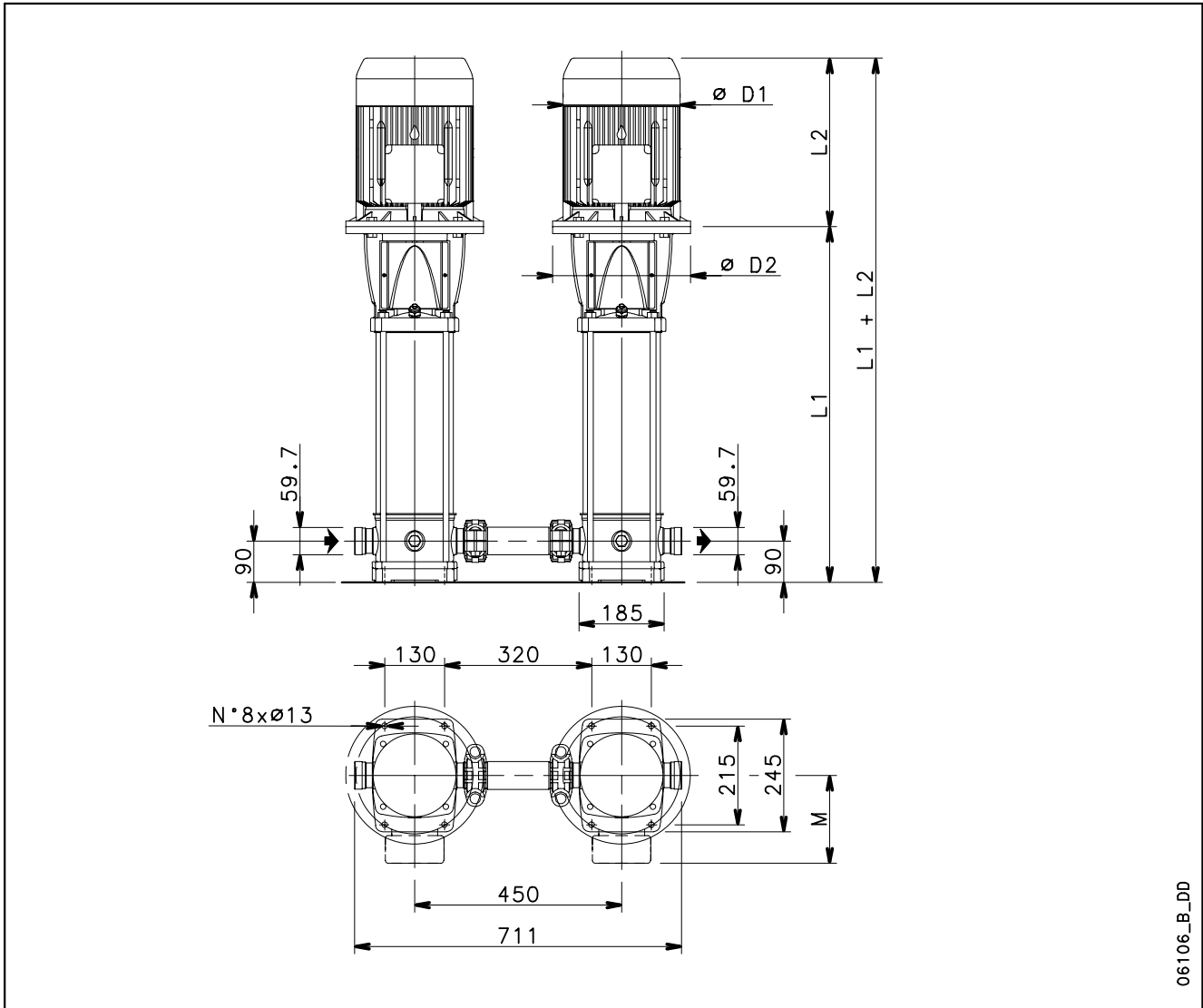

06106_B_DD

PUMP TYPE	MOTOR		DIMENSIONS (mm)					WEIGHT (Kg)	
	kW	Size	L1	L2	M	D1	D2	PUMP	ELECTRIC PUMP
15SV08P..	7,5	132	774	367	191	256	300	34	90
15SV09P..	7,5	132	822	367	191	256	300	35,6	92
15SV10P..	11	160	900	428	191	256	350	40,1	111
15SV11P..	11	160	948	428	191	256	350	41,7	113
15SV13P..	11	160	1044	428	191	256	350	45	116
15SV15P..	15	160	1140	494	240	313	350	48,4	151
15SV17P..	15	160	1236	494	240	313	350	52	154

Dimensions and weights are related to one electric pump.

15sv-p-2p50-en_b_td

**15SV..P SERIES - HIGH PRESSURE
OPERATING CHARACTERISTICS AT 50 Hz, 2-POLE**

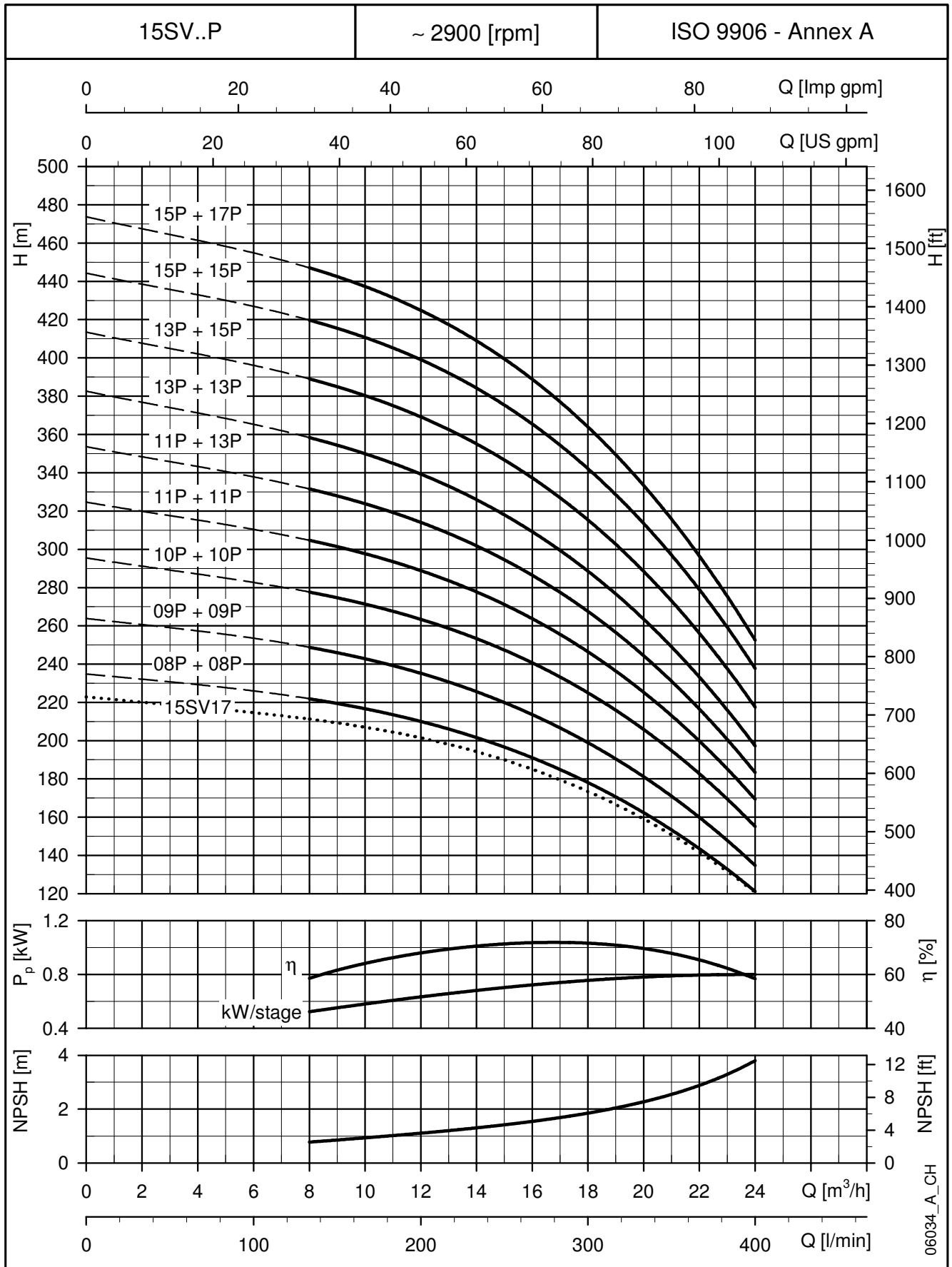

HIGH PRESSURE 50HZ

These performances are valid for liquids with density $\rho = 1.0 \text{ Kg/dm}^3$ and kinematic viscosity $\nu = 1 \text{ mm}^2/\text{sec}$.

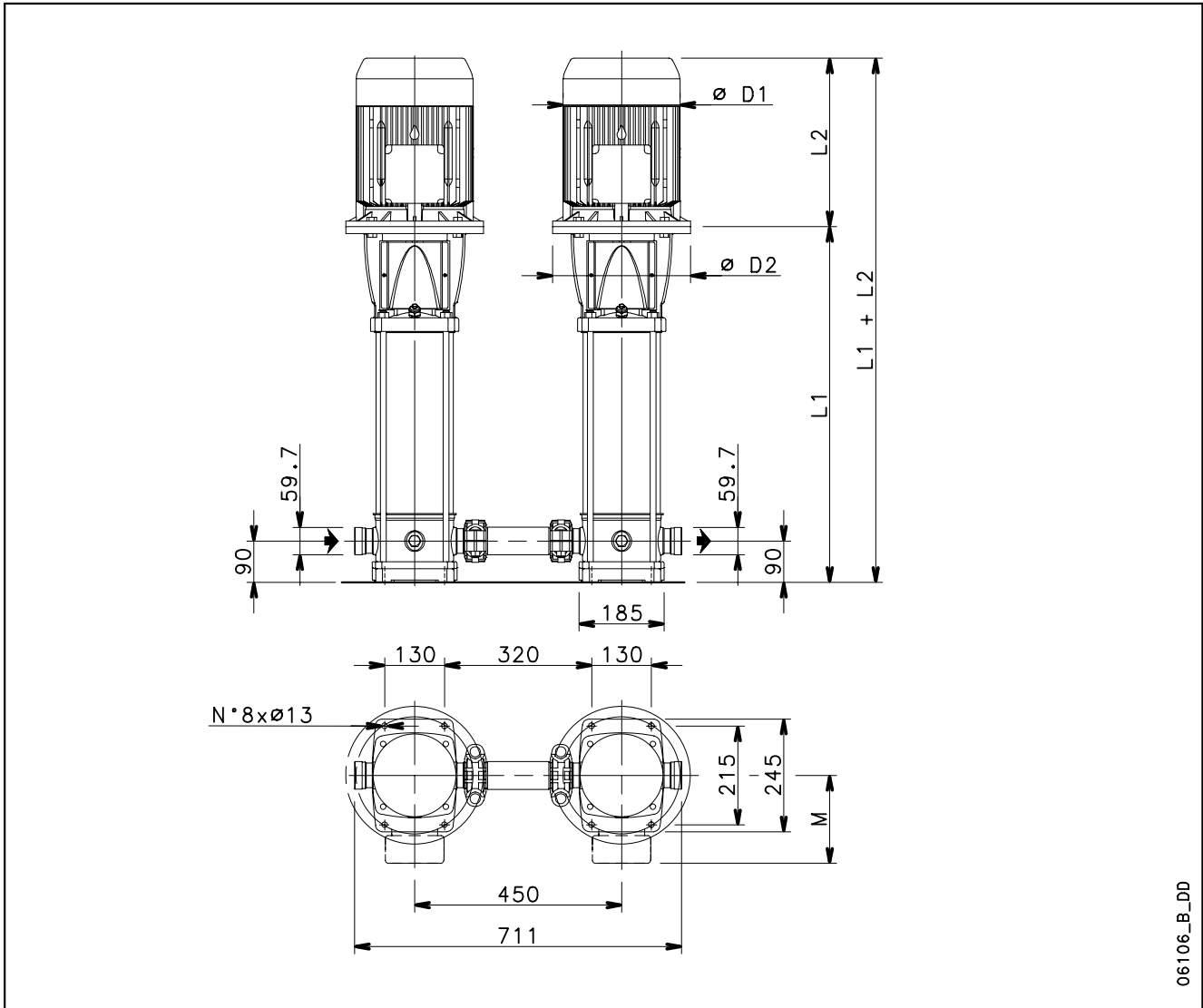
**22SV..P SERIES - HIGH PRESSURE
 DIMENSIONS AND WEIGHTS AT 50 Hz, 2-POLE**
**HIGH
 PRESSURE
 50Hz**

06106_B_DD

PUMP TYPE	MOTOR		DIMENSIONS (mm)					WEIGHT (Kg)	
	kW	Size	L1	L2	M	D1	D2	PUMP	ELECTRIC PUMP
22SV09P..	11	160	852	428	191	256	350	37,2	108
22SV10P..	11	160	900	428	191	256	350	40	111
22SV12P..	15	160	996	494	240	313	350	42,2	145
22SV14P..	15	160	1092	494	240	313	350	45,5	148

Dimensions and weights are related to one electric pump.

22sv-p-2p50-en_b_td

**22SV..P SERIES - HIGH PRESSURE
OPERATING CHARACTERISTICS AT 50 Hz, 2-POLE**

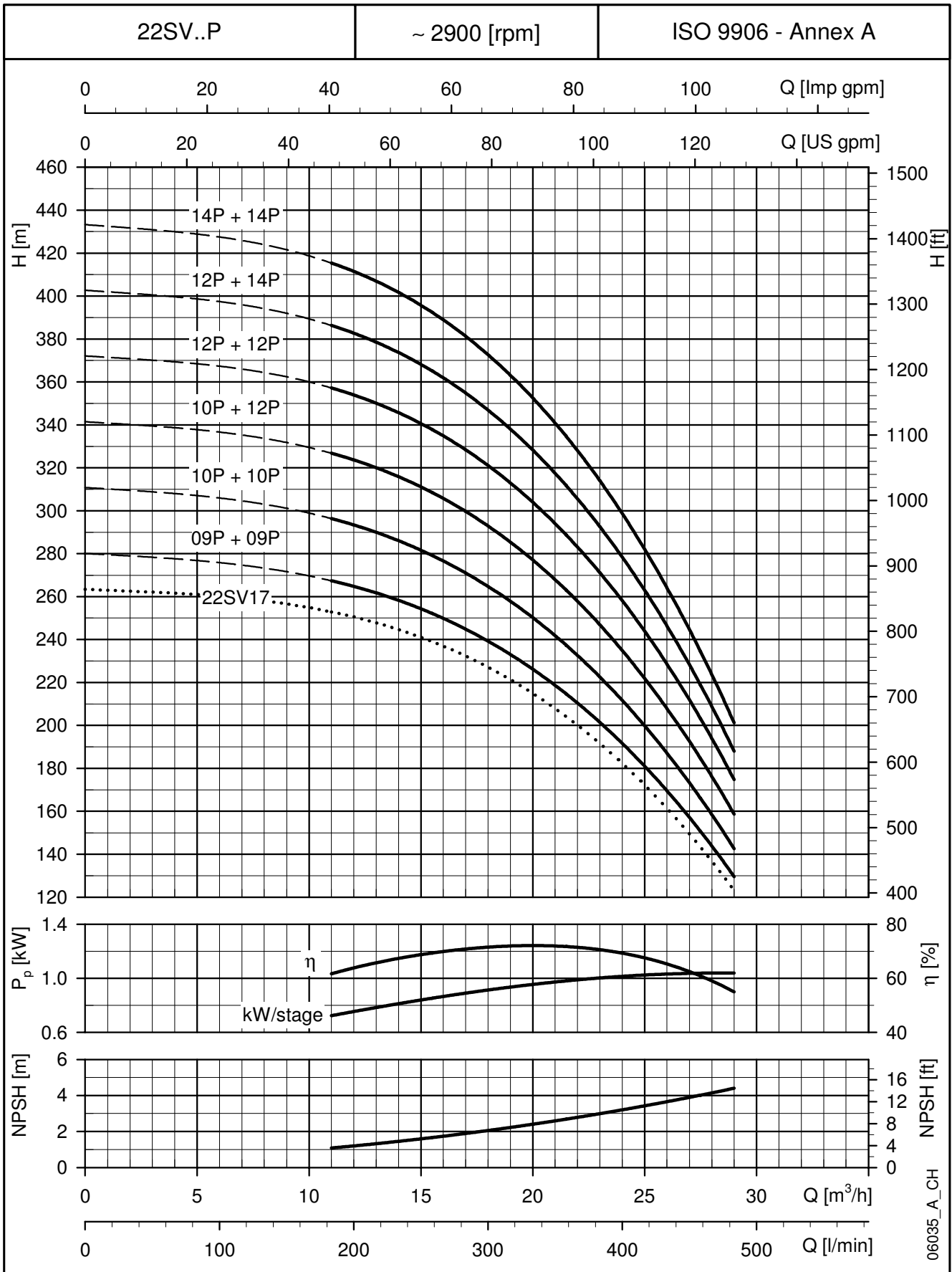

HIGH PRESSURE 50HZ

These performances are valid for liquids with density $\rho = 1.0 \text{ Kg/dm}^3$ and kinematic viscosity $\nu = 1 \text{ mm}^2/\text{sec}$.

**33SV..P SERIES - HIGH PRESSURE
DIMENSIONS AND WEIGHTS AT 50 Hz, 2-POLE**

**HIGH
PRESSURE
50Hz**

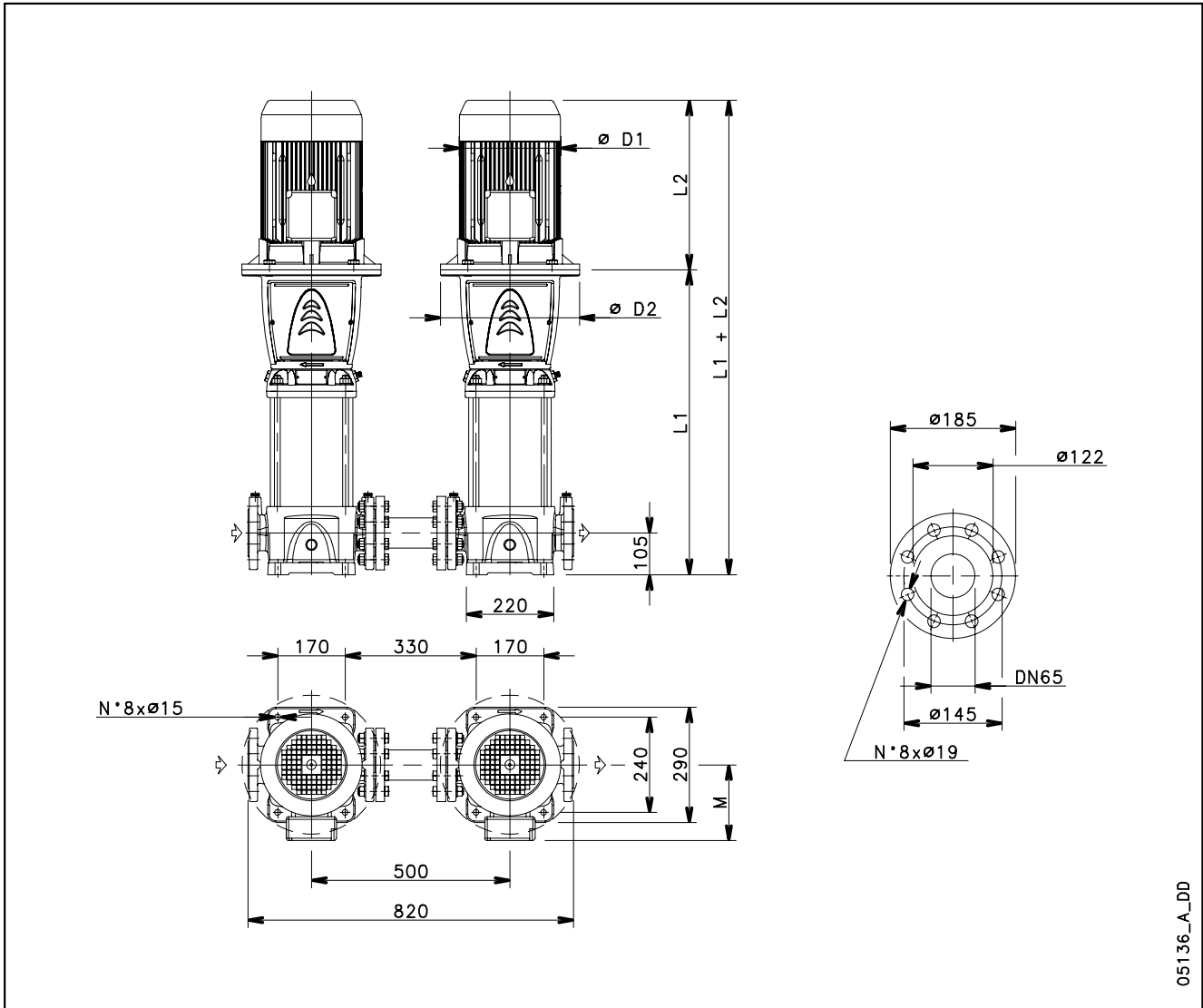

05136_A_DD

PUMP TYPE	MOTOR		DIMENSION (mm)					WEIGHT (Kg)	
	kW	Size	L1	L2	M	D1	D2	PUMP	ELECTRIC PUMP
33SV7/2AP..	15	160	994	494	240	313	350	88	190
33SV8/1AP..	18,5	160	1069	494	240	313	350	93	204
33SV9P..	22	180	1144	494	240	313	350	98	219
33SV10/2AP..	22	180	1219	494	240	313	350	103	224

Dimensions and weights are related to one electric pump.

33sv-p-2p50-en_b_td

33SV..P SERIES - HIGH PRESSURE OPERATING CHARACTERISTICS AT 50 Hz, 2-POLE

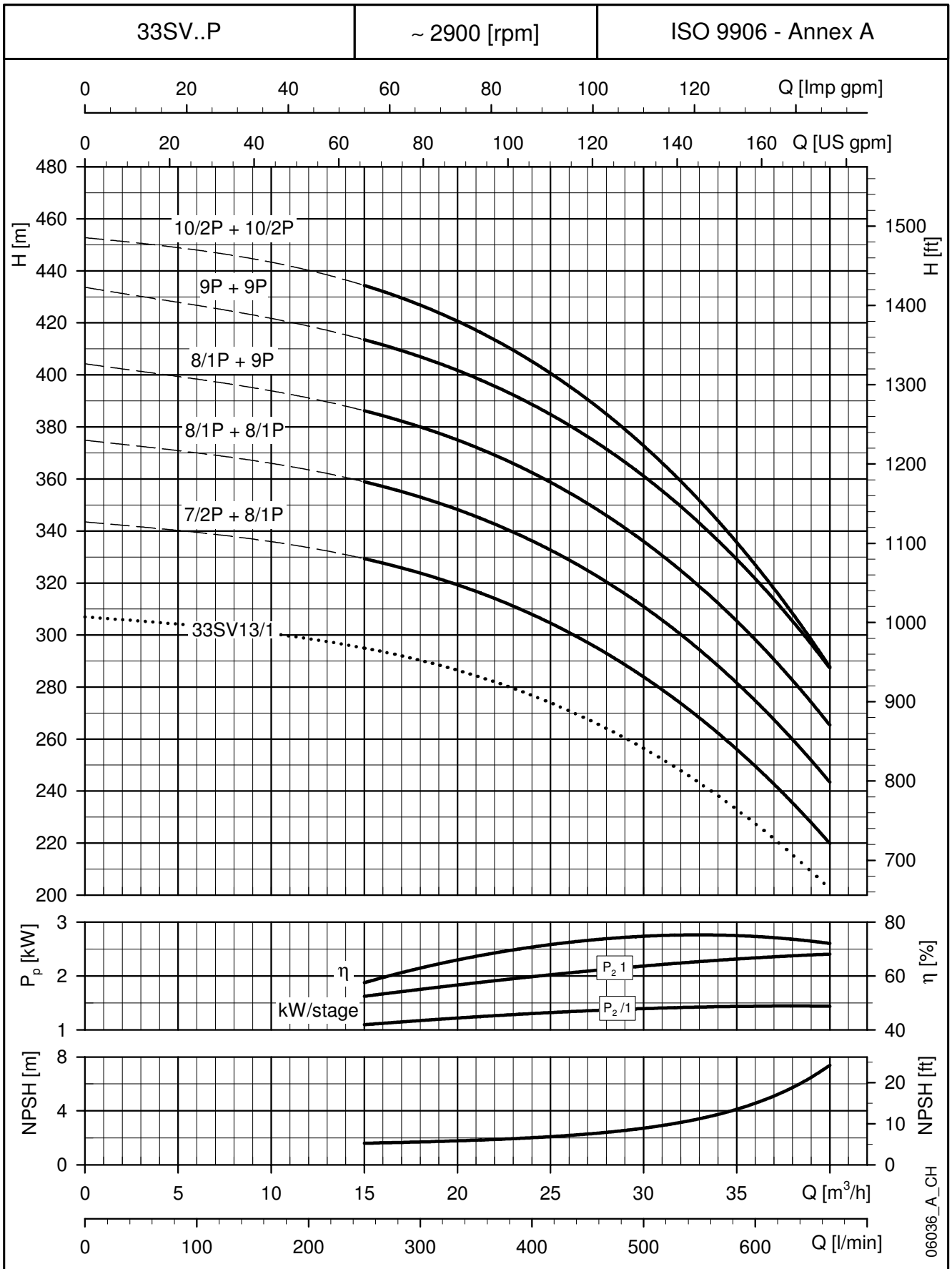

HIGH PRESSURE 50HZ

These performances are valid for liquids with density $\rho = 1.0 \text{ Kg/dm}^3$ and kinematic viscosity $\nu = 1 \text{ mm}^2/\text{sec}$.

46SV..P SERIES - HIGH PRESSURE DIMENSIONS AND WEIGHTS AT 50 Hz, 2-POLE

HIGH PRESSURE 50HZ

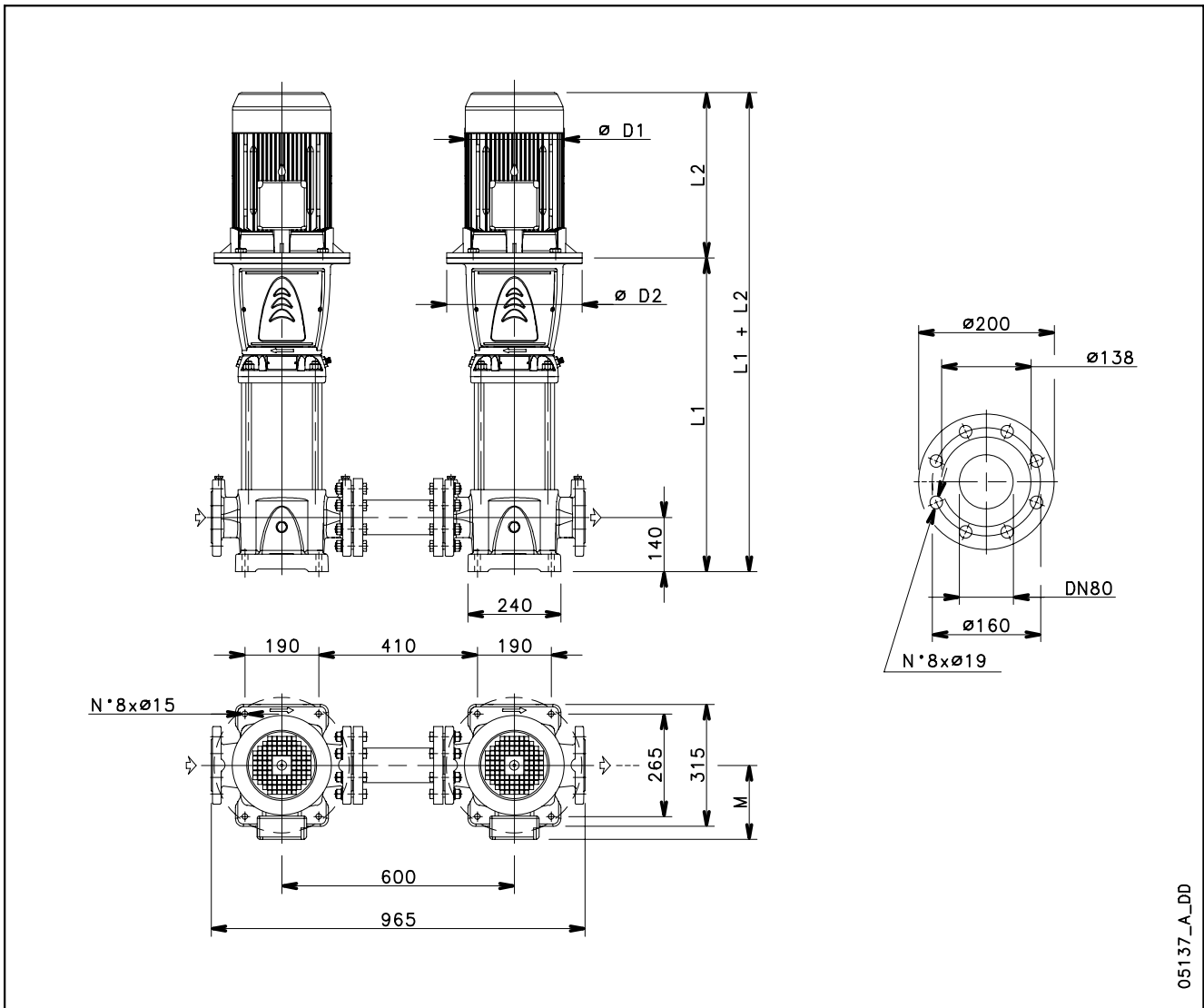

05137_A_DD

PUMP TYPE	MOTOR		DIMENSION (mm)					WEIGHT (Kg)	
	kW	Size	L1	L2	M	D1	D2	PUMP	ELECTRIC PUMP
46SV6P..	22	180	959	494	240	313	350	91	212
46SV7P..	30	200	1034	657	317	402	400	101	327
46SV8P..	30	200	1109	657	317	402	400	106	332
46SV9/2AP..	30	200	1184	657	317	402	400	110	336

Dimensions and weights are related to one electric pump.

46sv-p-2p50-en_b_td

**46SV..P SERIES - HIGH PRESSURE
OPERATING CHARACTERISTICS AT 50 Hz, 2-POLE**

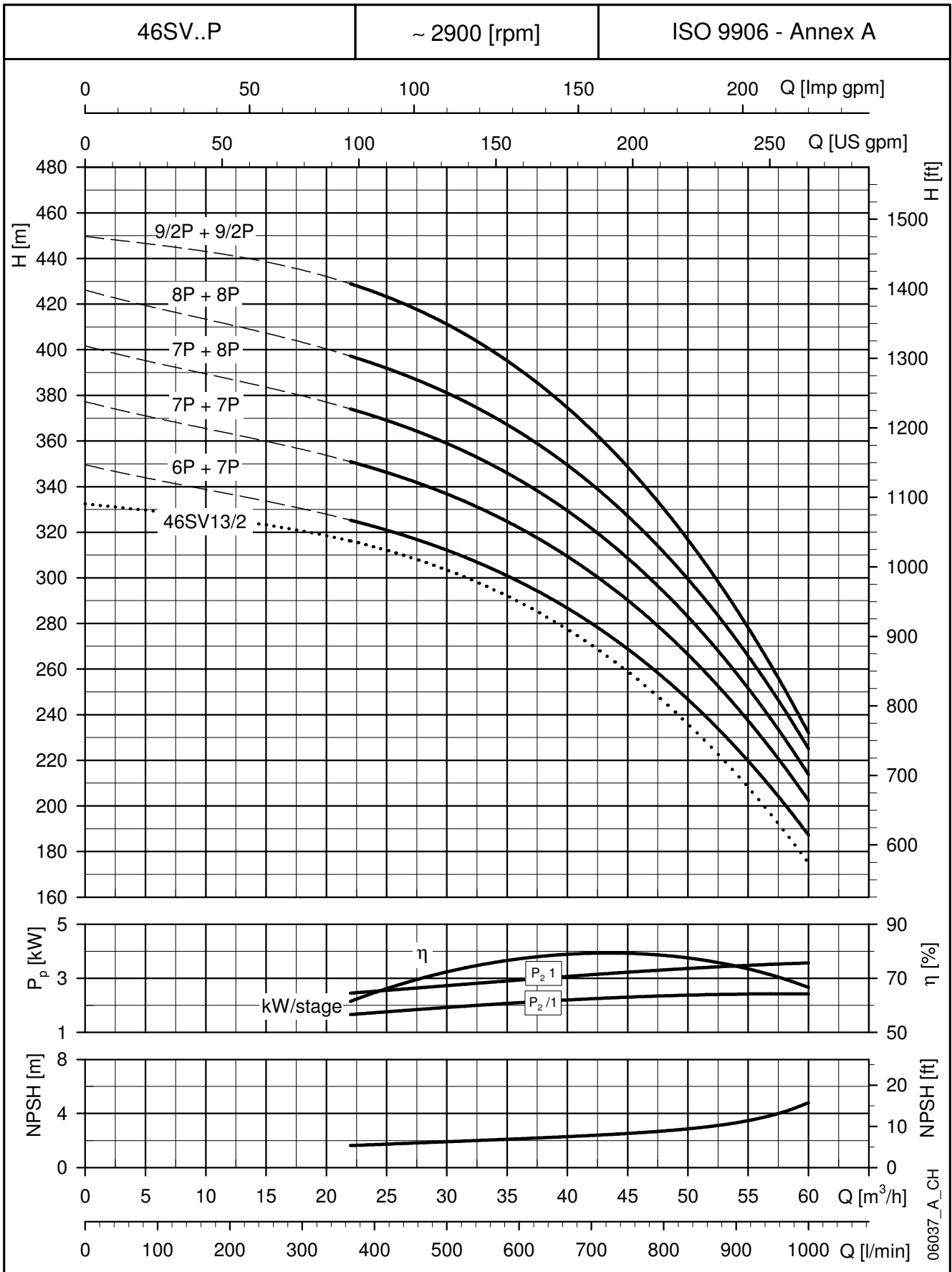

HIGH PRESSURE 50HZ

These performances are valid for liquids with density ρ = 1.0 Kg/dm³ and kinematic viscosity ν = 1 mm²/sec.

**66SV..P SERIES - HIGH PRESSURE
DIMENSIONS AND WEIGHTS AT 50 Hz, 2-POLE**

**HIGH
PRESSURE
50Hz**

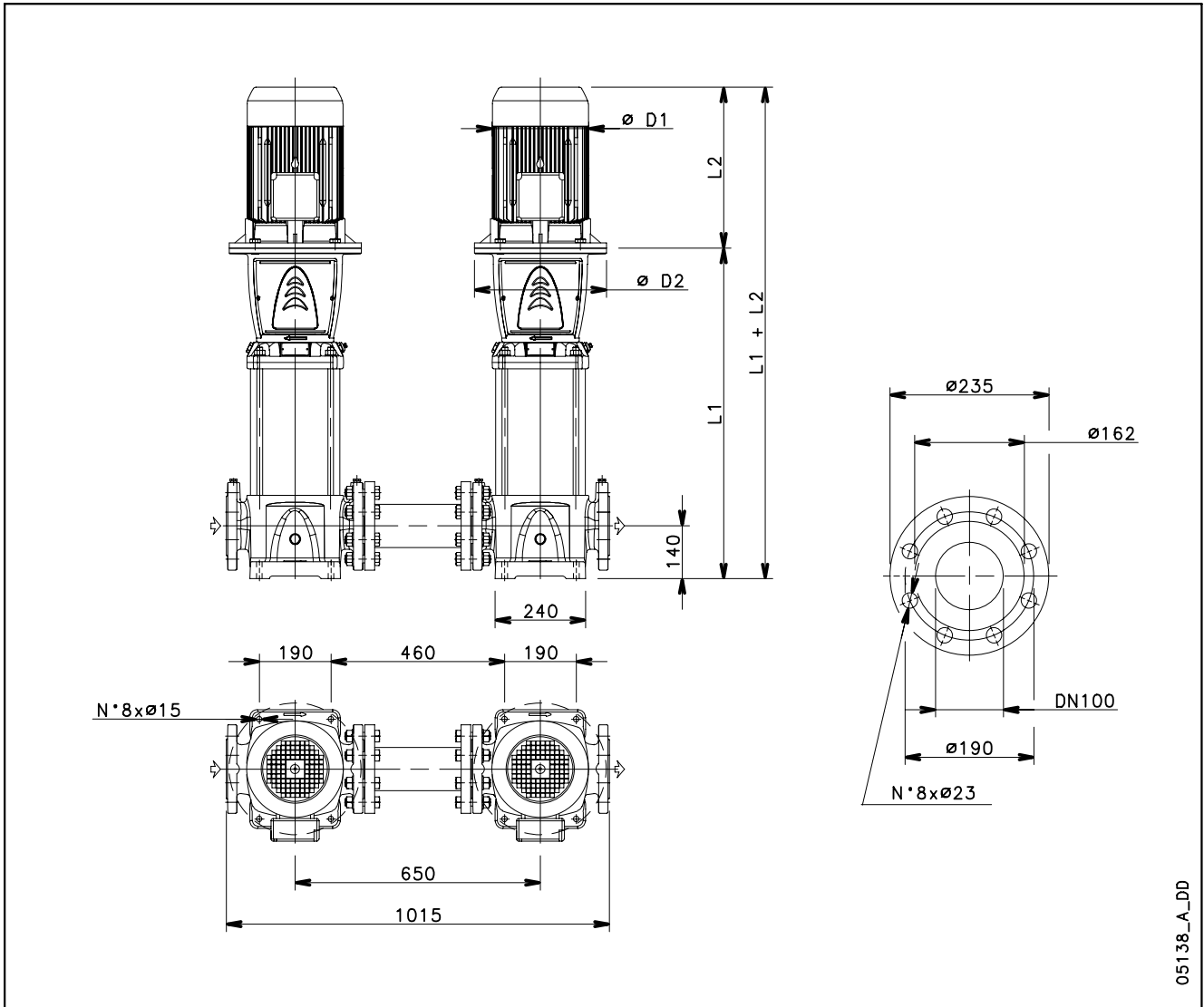

05138_A_DD

PUMP TYPE	MOTOR		DIMENSION (mm)					WEIGHT (Kg)	
	kW	Size	L1	L2	M	D1	D2	PUMP	ELECTRIC PUMP
66SV4P..	22	180	879	494	240	313	350	97	218
66SV5P..	30	200	969	657	317	402	400	110	336
66SV6/1AP..	30	200	1059	657	317	402	400	119	345
66SV7/1AP..	37	200	1149	657	317	402	400	125	380
66SV8P..	45	225	1239	746	384	455	450	135	491

Dimensions and weights are related to one electric pump.

66sv-p-2p50-en_b_td

66SV..P SERIES - HIGH PRESSURE OPERATING CHARACTERISTICS AT 50 Hz, 2-POLE

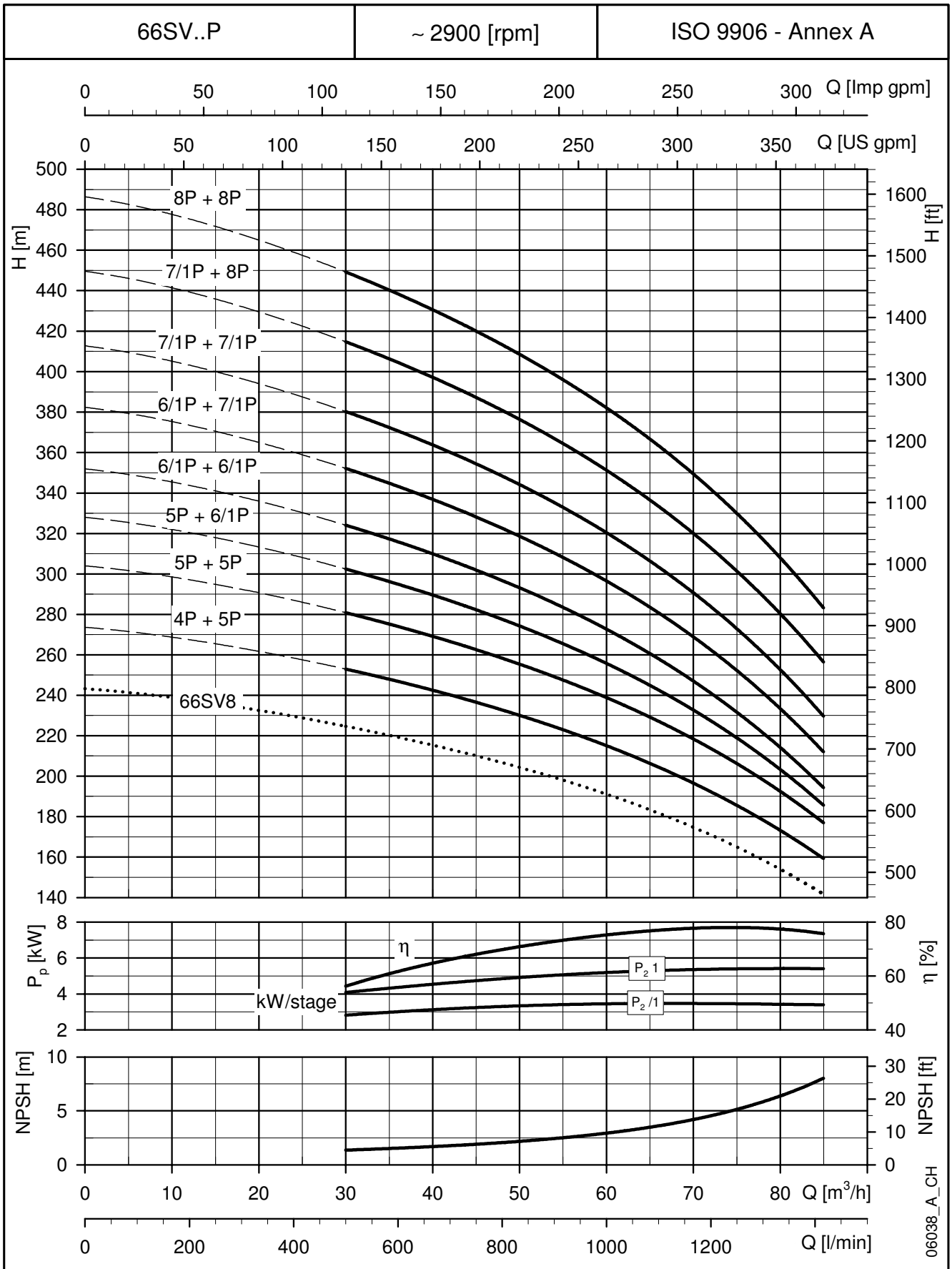

HIGH PRESSURE 50HZ

06038_A_CH

These performances are valid for liquids with density $\rho = 1.0 \text{ Kg/dm}^3$ and kinematic viscosity $\nu = 1 \text{ mm}^2/\text{sec}$.

**92SV..P SERIES - HIGH PRESSURE
DIMENSIONS AND WEIGHTS AT 50 Hz, 2-POLE**

**HIGH
PRESSURE
50Hz**

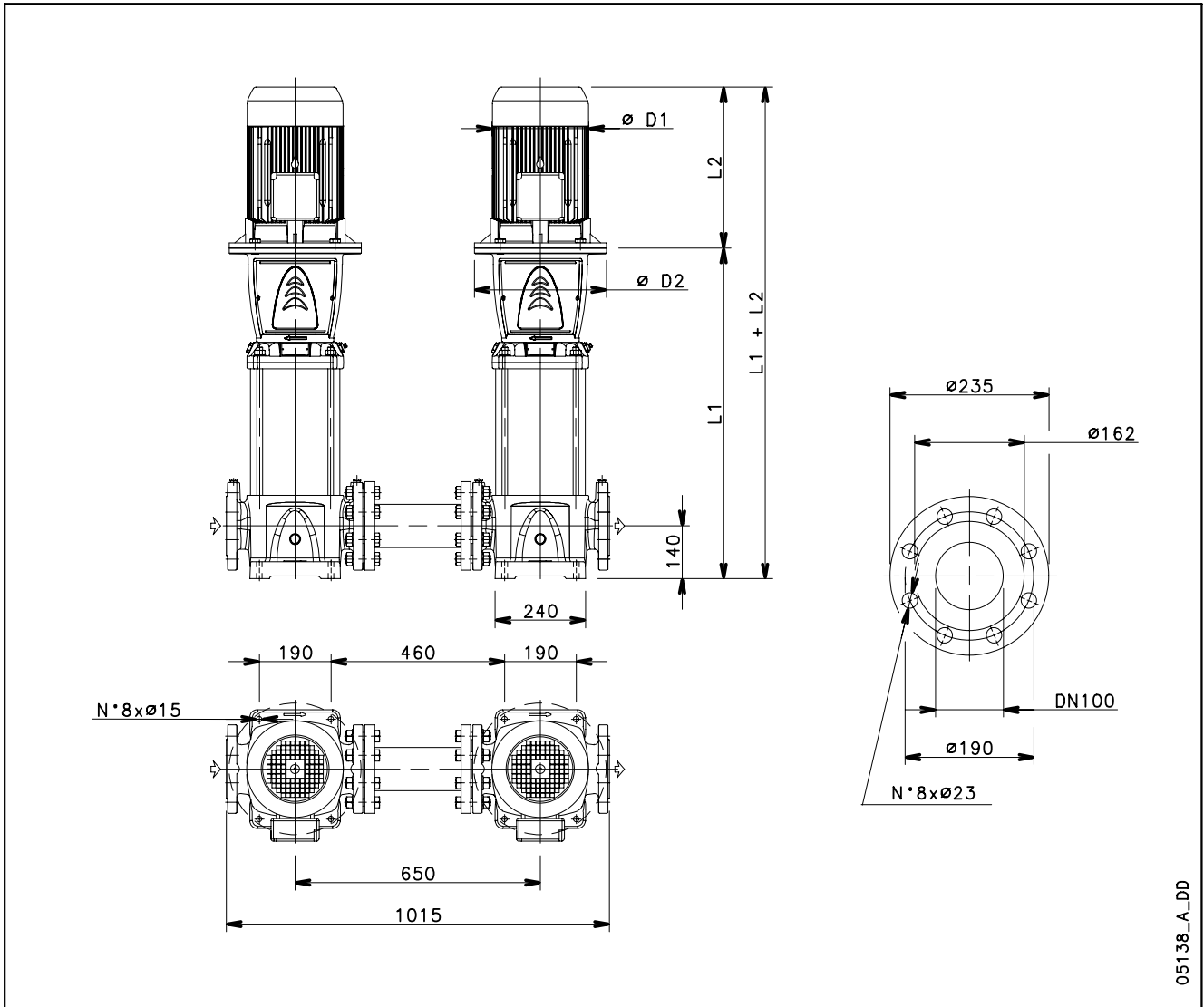

PUMP TYPE	MOTOR		DIMENSION (mm)					WEIGHT (Kg)	
	kW	Size	L1	L2	M	D1	D2	PUMP	ELECTRIC PUMP
92SV4/2AP..	30	200	879	657	317	402	400	103	329
92SV4P..	30	200	879	657	317	402	400	103	329
92SV5P..	37	200	969	657	317	402	400	112	367
92SV6P..	45	225	1059	746	384	455	450	122	478
92SV7/2AP..	45	225	1149	746	384	455	450	128	484

Dimensions and weights are related to one electric pump.

92sv-p-2p50-en_b_td

92SV..P SERIES - HIGH PRESSURE OPERATING CHARACTERISTICS AT 50 Hz, 2-POLE

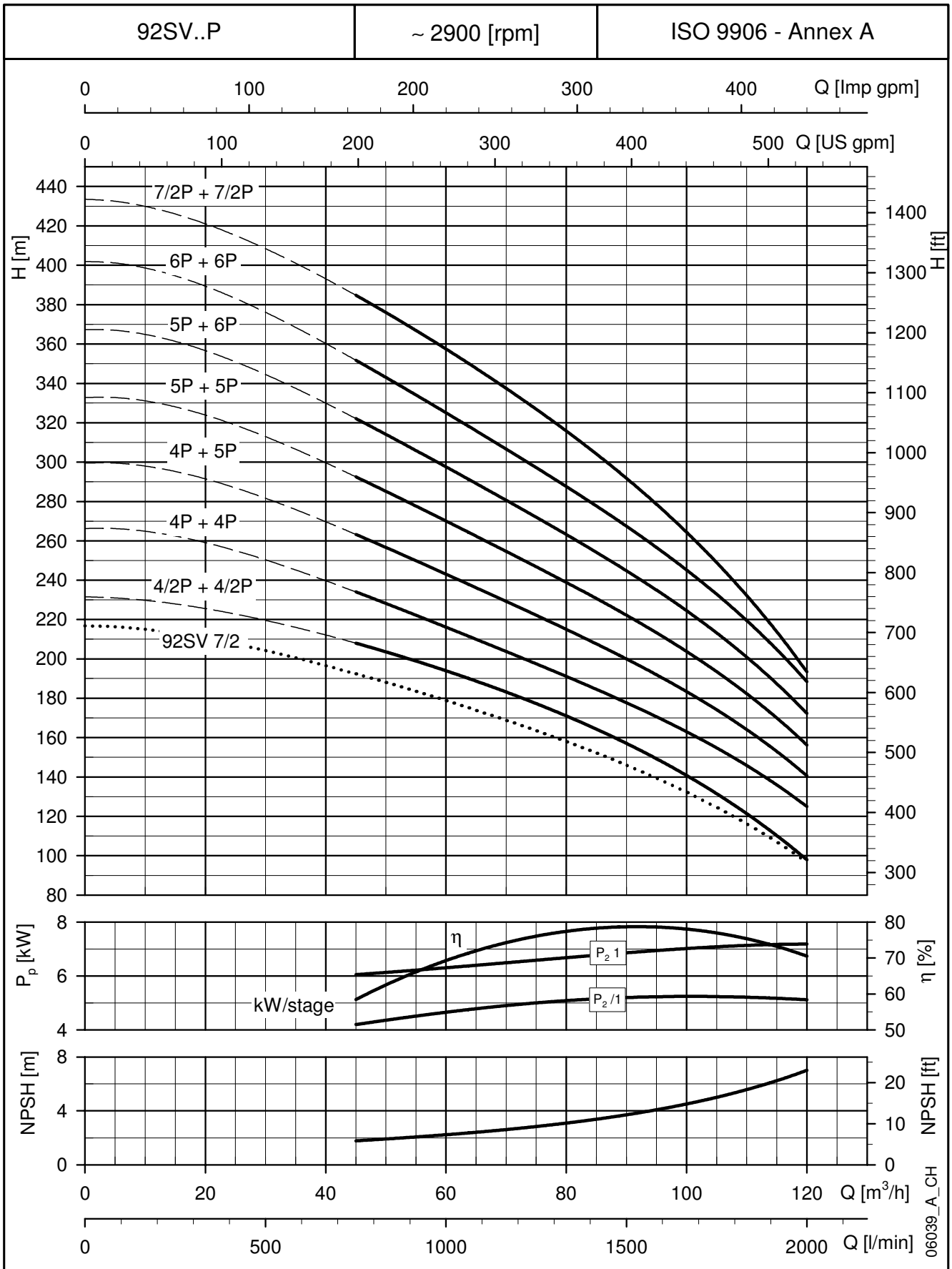

HIGH PRESSURE 50HZ

These performances are valid for liquids with density $\rho = 1.0 \text{ Kg/dm}^3$ and kinematic viscosity $\nu = 1 \text{ mm}^2/\text{sec}$.

125SV..P SERIES - HIGH PRESSURE DIMENSIONS AND WEIGHTS AT 50 Hz, 2-POLE

HIGH PRESSURE 50Hz

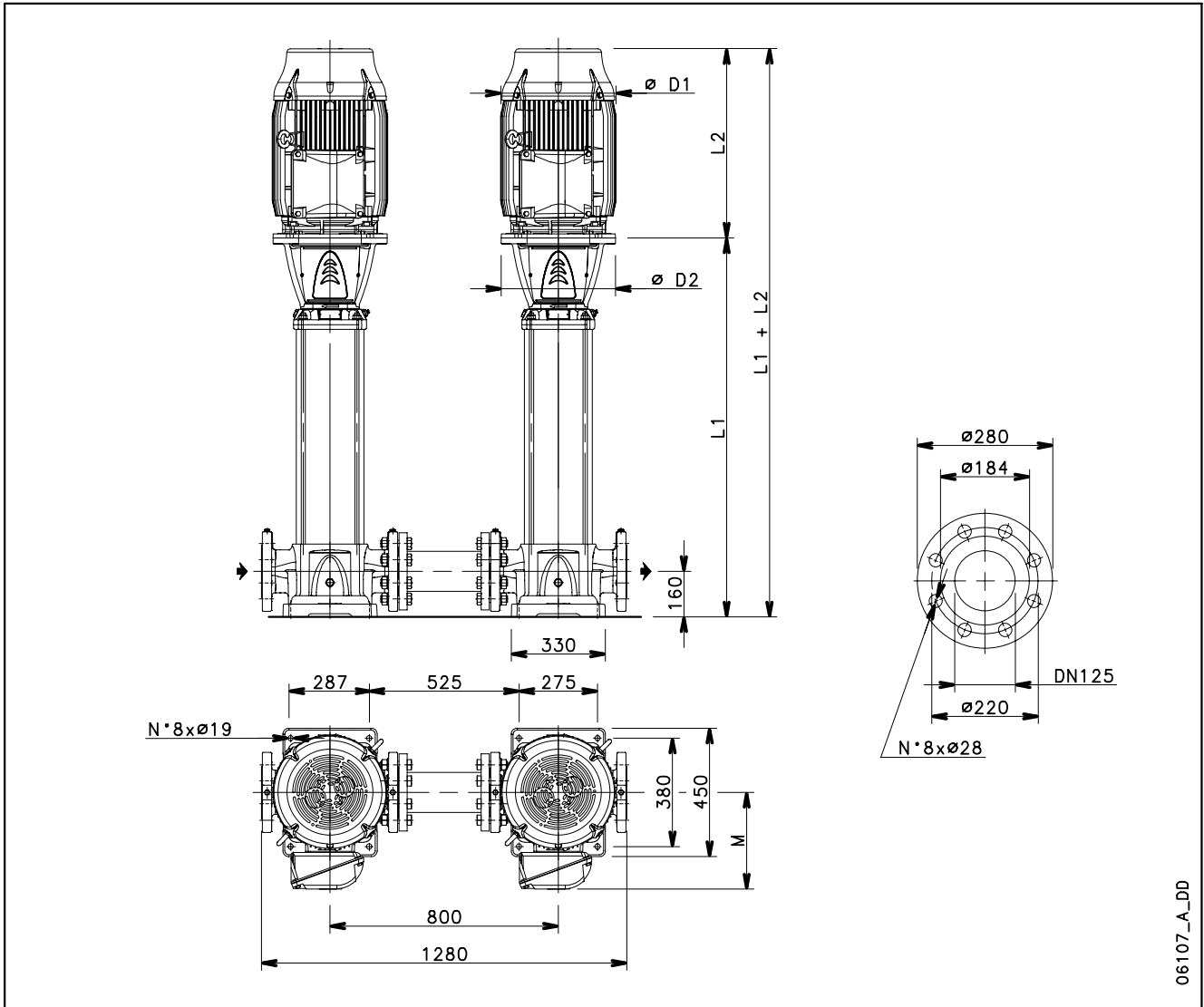

06107_A_DD

PUMP TYPE	MOTOR		DIMENSION (mm)					WEIGHT (Kg)	
	kW	Size	L1	L2	M	D1	D2	PUMP	ELECTRIC PUMP
125SV4P..	30	200	1178	657	317	402	400	168	394
125SV5P..	37	200	1328	657	317	402	400	181	436
125SV6P..	45	225	1478	746	384	455	450	198	554
125SV7P..	55	250	1658	825	402	486	550	228	641

Dimensions and weights are related to one electric pump.

125sv-p-2p50-en_b_td

**125SV..P SERIES - HIGH PRESSURE
OPERATING CHARACTERISTICS AT 50 Hz, 2-POLE**

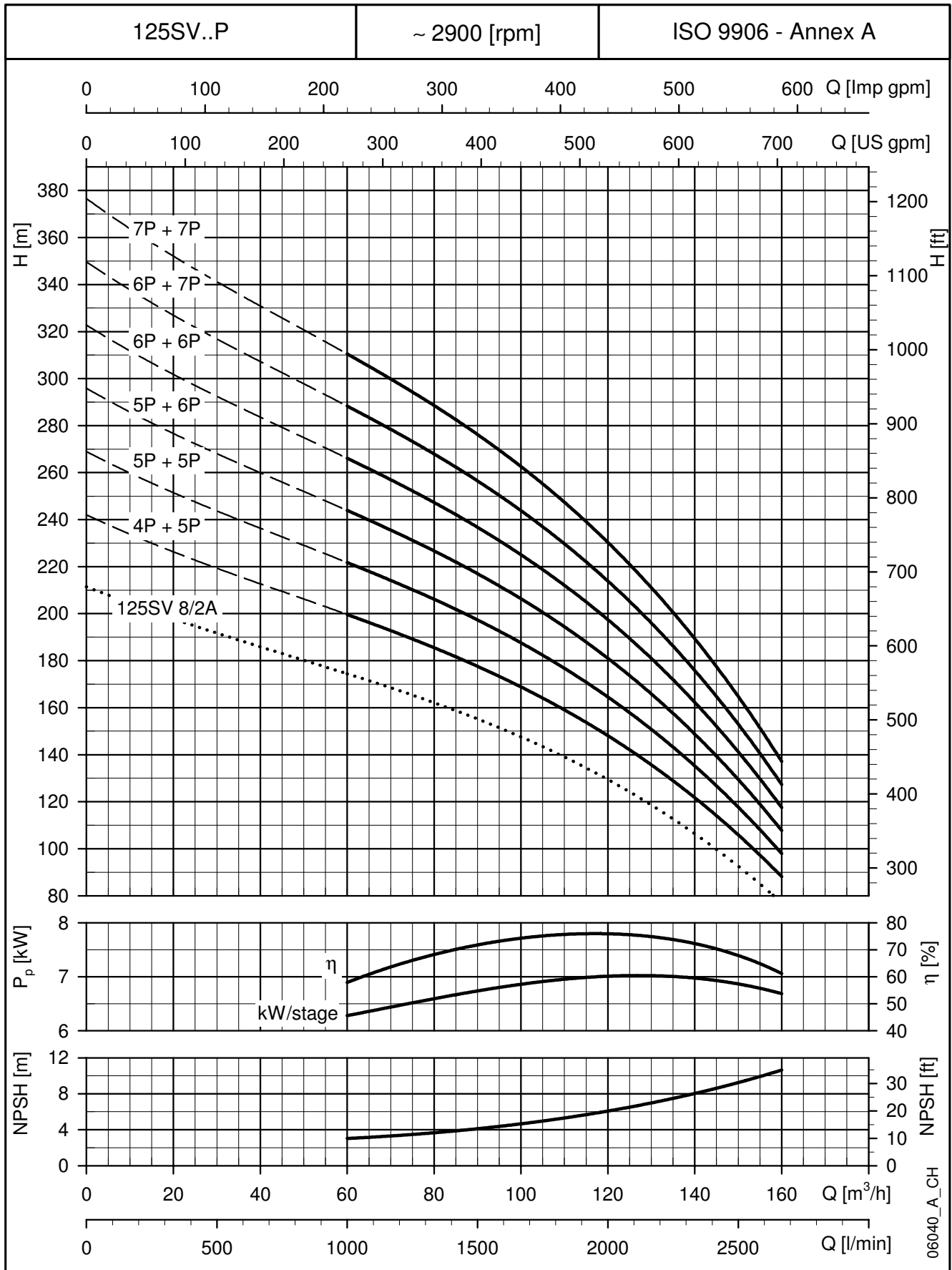

HIGH PRESSURE 50HZ

These performances are valid for liquids with density $\rho = 1.0 \text{ Kg/dm}^3$ and kinematic viscosity $\nu = 1 \text{ mm}^2/\text{sec}$.

1SV..P SERIES - HIGH PRESSURE DIMENSIONS AND WEIGHTS AT 60 Hz, 2-POLE

HIGH PRESSURE 60Hz

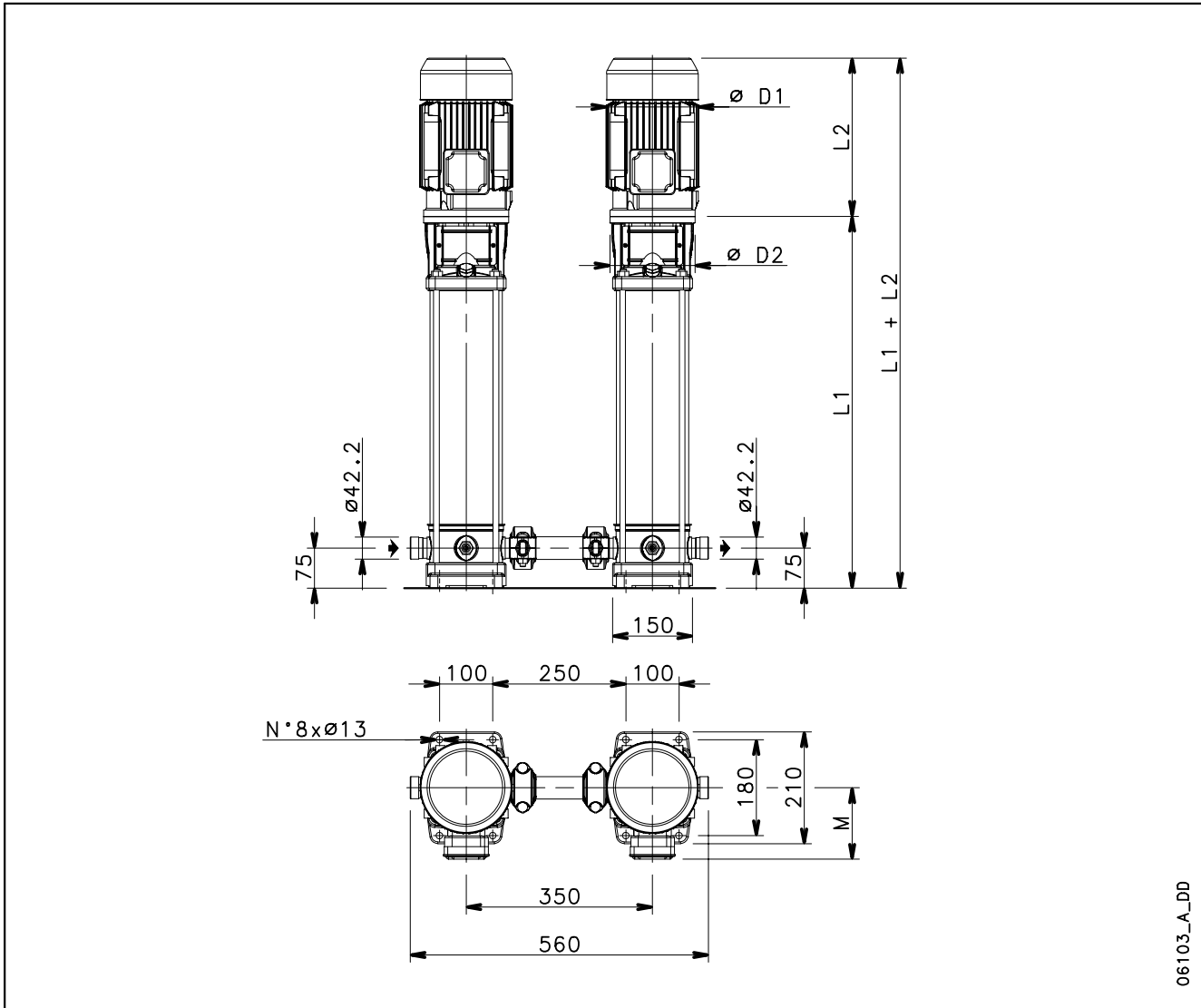

06103_A_DD

PUMP TYPE	MOTOR		DIMENSIONS (mm)					WEIGHT (Kg)	
	kW	Size	L1	L2	M	D1	D2	PUMP	ELECTRIC PUMP
1SV15P../D	1,5	90	558	263	129	155	140	15,8	28,8
1SV17P../D	1,5	90	598	263	129	155	140	16,8	28,8
1SV18P..	2,2	90	618	298	134	174	140	17,2	35,4
1SV20P..	2,2	90	658	298	134	174	140	18,2	36,4
1SV22P..	2,2	90	698	298	134	174	140	19,2	37,4
1SV24P..	2,2	90	738	298	134	174	140	20,1	38,3
1SV26P..	2,2	90	778	298	134	174	140	21,1	39,3

Dimensions and weights are related to one electric pump.

1sv-p-2p60-en_c_td

**1SV..P SERIES - HIGH PRESSURE
OPERATING CHARACTERISTICS AT 60 Hz, 2-POLE**

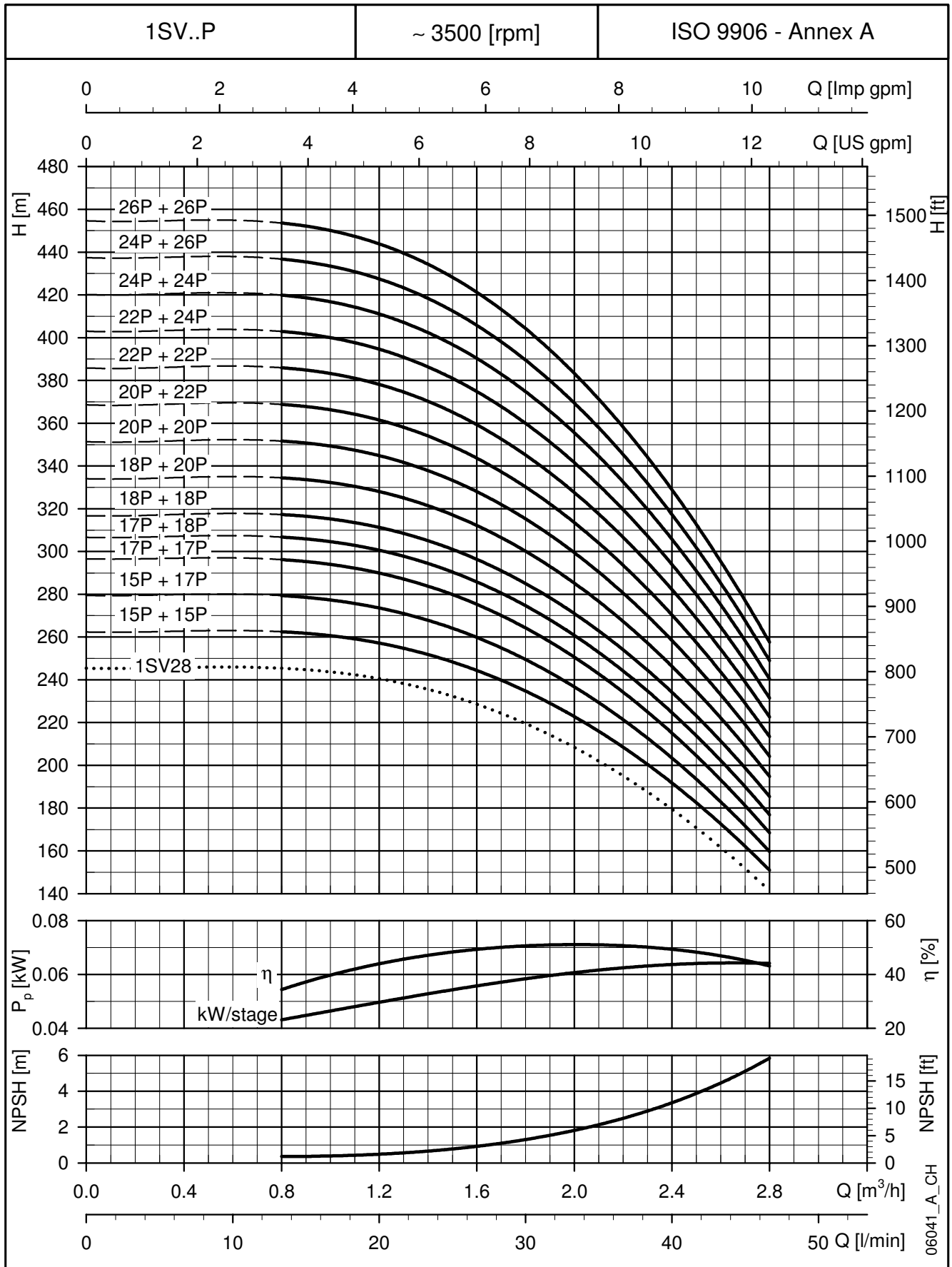

HIGH PRESSURE 60HZ

These performances are valid for liquids with density $\rho = 1.0 \text{ Kg/dm}^3$ and kinematic viscosity $\nu = 1 \text{ mm}^2/\text{sec}$.

3SV..P SERIES - HIGH PRESSURE DIMENSIONS AND WEIGHTS AT 60 Hz, 2-POLE

HIGH PRESSURE 60Hz

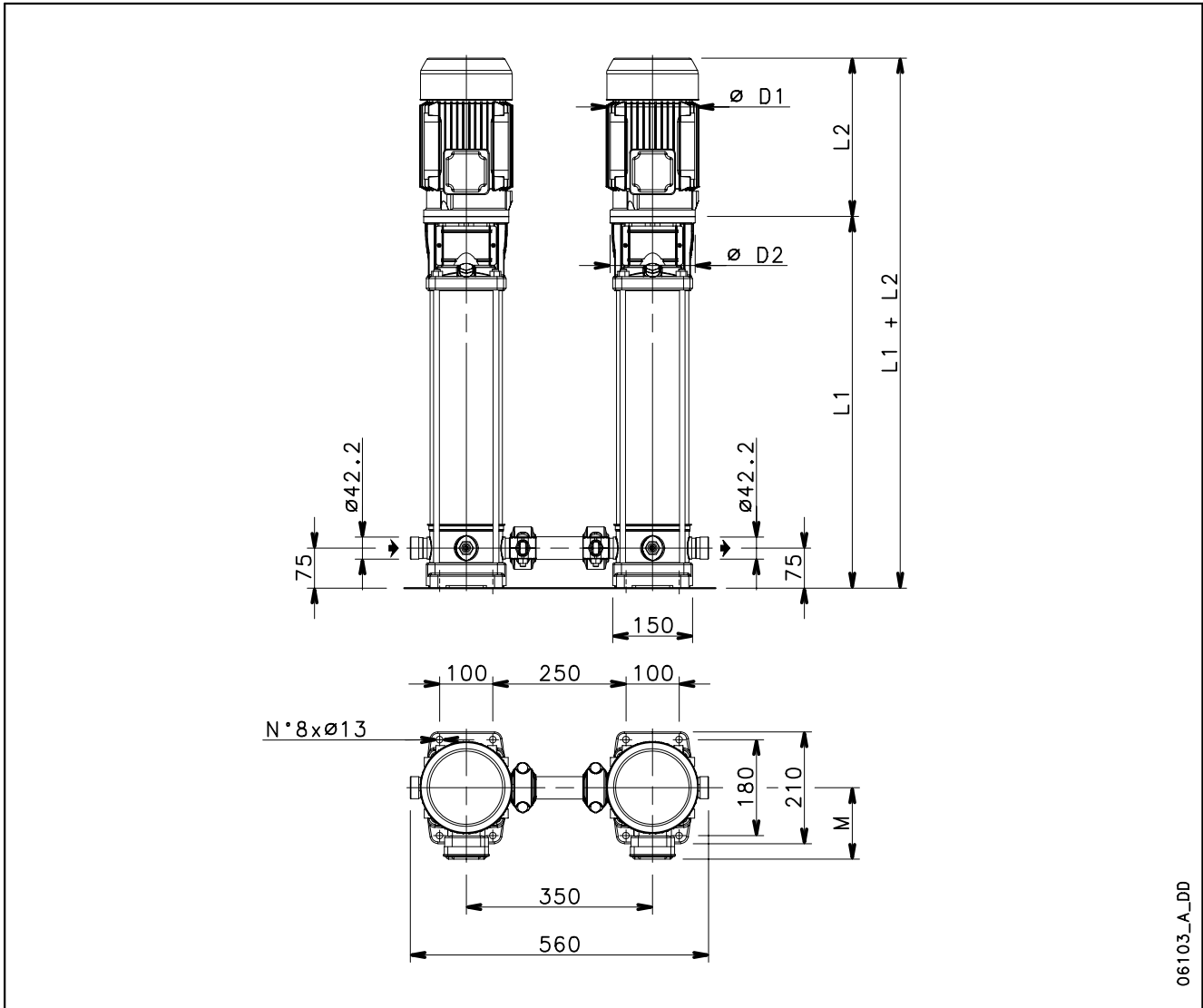

06103_A_DD

PUMP TYPE	MOTOR		DIMENSIONS (mm)					WEIGHT (Kg)	
	kW	Size	L1	L2	M	D1	D2	PUMP	ELECTRIC PUMP
3SV12P..	2,2	90	498	298	134	174	140	14,2	32,4
3SV13P..	2,2	90	518	298	134	174	140	14,7	32,9
3SV14P..	2,2	90	538	298	134	174	140	15,2	33,4
3SV15P..	3	100	568	298	134	174	160	16,1	37,1
3SV17P..	3	100	608	298	134	174	160	17	38
3SV19P..	3	100	648	298	134	174	160	18	39
3SV21P..	4	112	688	319	154	197	160	19	45,4

Dimensions and weights are related to one electric pump.

3sv-p-2p60-en_c_td

**3SV..P SERIES - HIGH PRESSURE
OPERATING CHARACTERISTICS AT 60 Hz, 2-POLE**

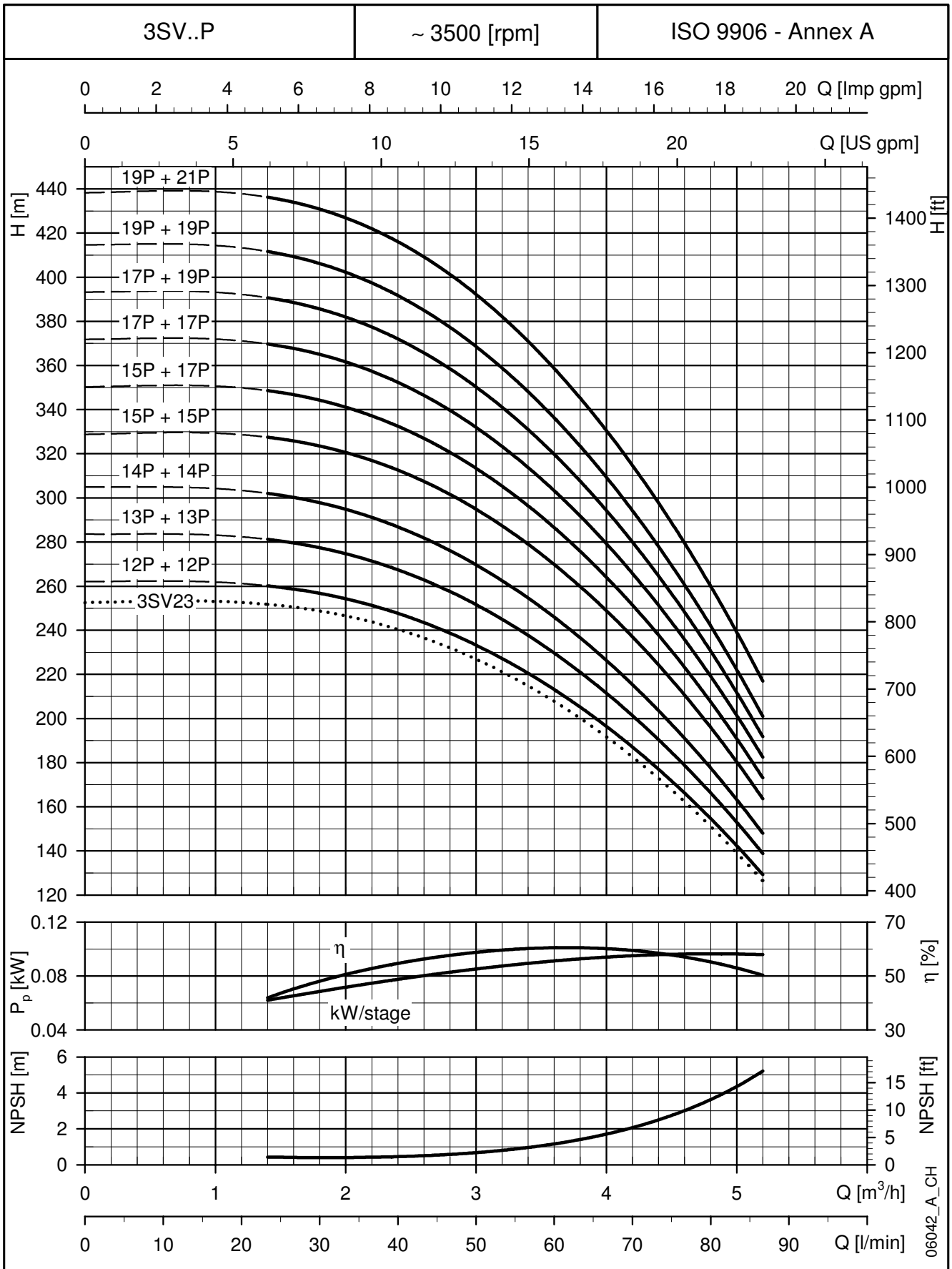

HIGH PRESSURE 60HZ

These performances are valid for liquids with density $\rho = 1.0 \text{ Kg/dm}^3$ and kinematic viscosity $\nu = 1 \text{ mm}^2/\text{sec}$.

5SV..P SERIES - HIGH PRESSURE DIMENSIONS AND WEIGHTS AT 60 Hz, 2-POLE

HIGH PRESSURE 60Hz

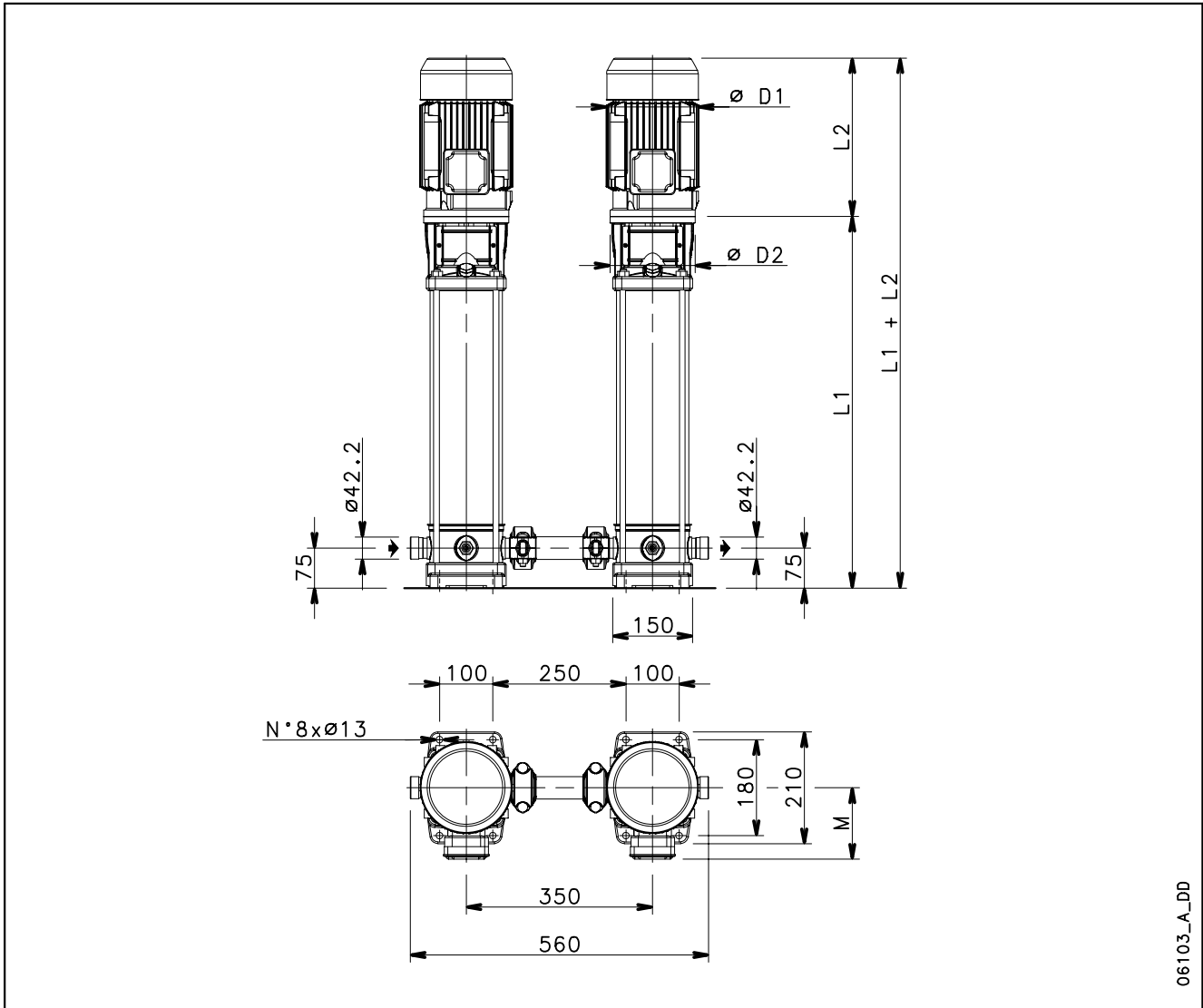

06103_A_DD

PUMP TYPE	MOTOR		DIMENSIONS (mm)					WEIGHT (Kg)	
	kW	Size	L1	L2	M	D1	D2	PUMP	ELECTRIC PUMP
5SV12P..	3	100	573	298	134	174	160	16,2	37,2
5SV13P..	4	112	598	319	154	197	160	16,8	43,2
5SV14P..	4	112	623	319	154	197	160	17,3	43,7
5SV15P..	4	112	648	319	154	197	160	17,9	44,3
5SV16P..	4	112	673	319	154	197	160	18,5	44,9
5SV17P..	5,5	132	718	375	168	214	300	23	61
5SV19P..	5,5	132	768	375	168	214	300	24	62
5SV21P..	5,5	132	818	375	168	214	300	25,3	63

Dimensions and weights are related to one electric pump.

5sv-p-2p60-en_c_td

**5SV..P SERIES - HIGH PRESSURE
OPERATING CHARACTERISTICS AT 60 Hz, 2-POLE**

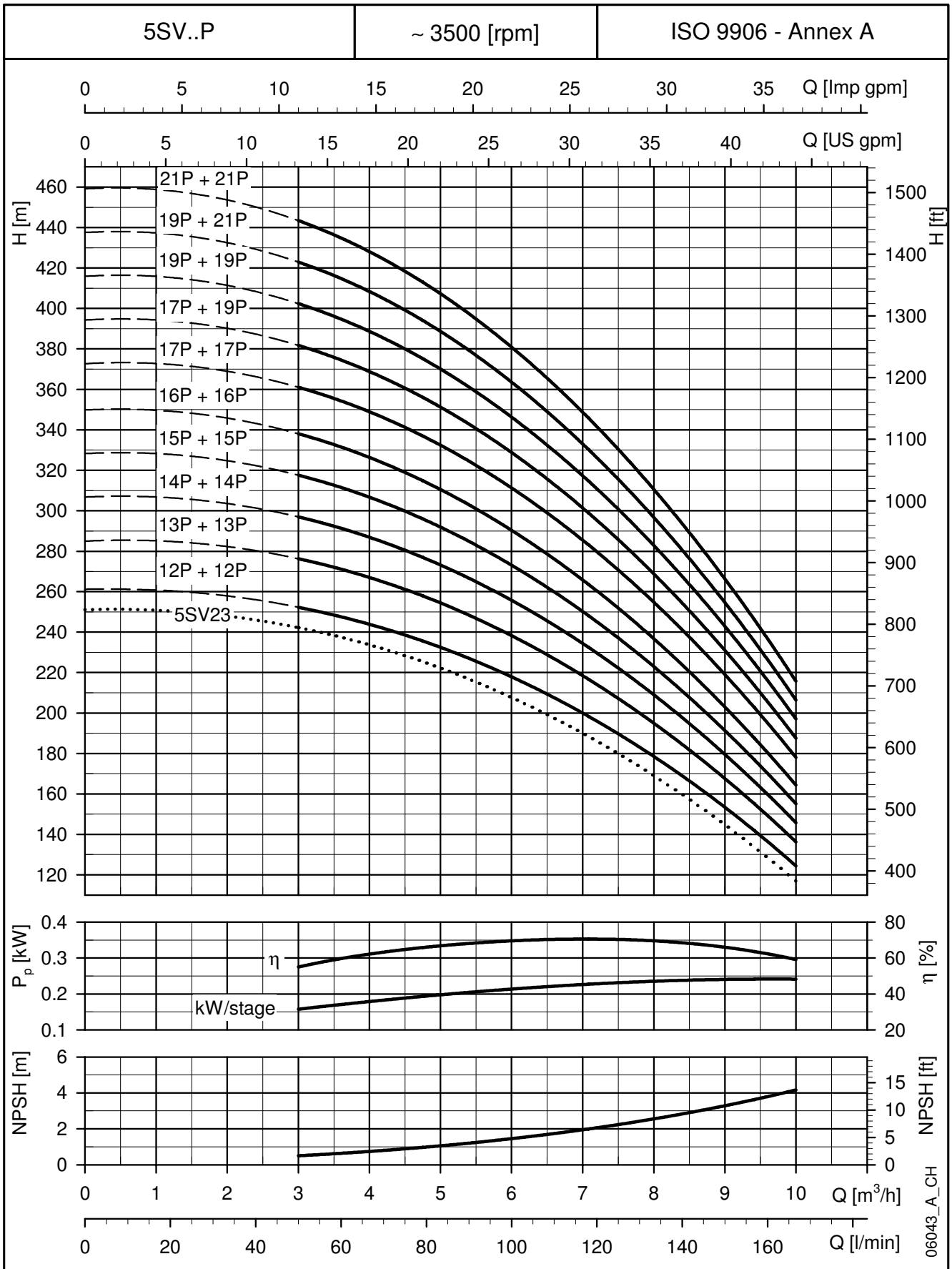

HIGH PRESSURE 60HZ

These performances are valid for liquids with density $\rho = 1.0 \text{ Kg/dm}^3$ and kinematic viscosity $\nu = 1 \text{ mm}^2/\text{sec}$.

10SV..P SERIES - HIGH PRESSURE DIMENSIONS AND WEIGHTS AT 60 Hz, 2-POLE

**HIGH
 PRESSURE
 60Hz**

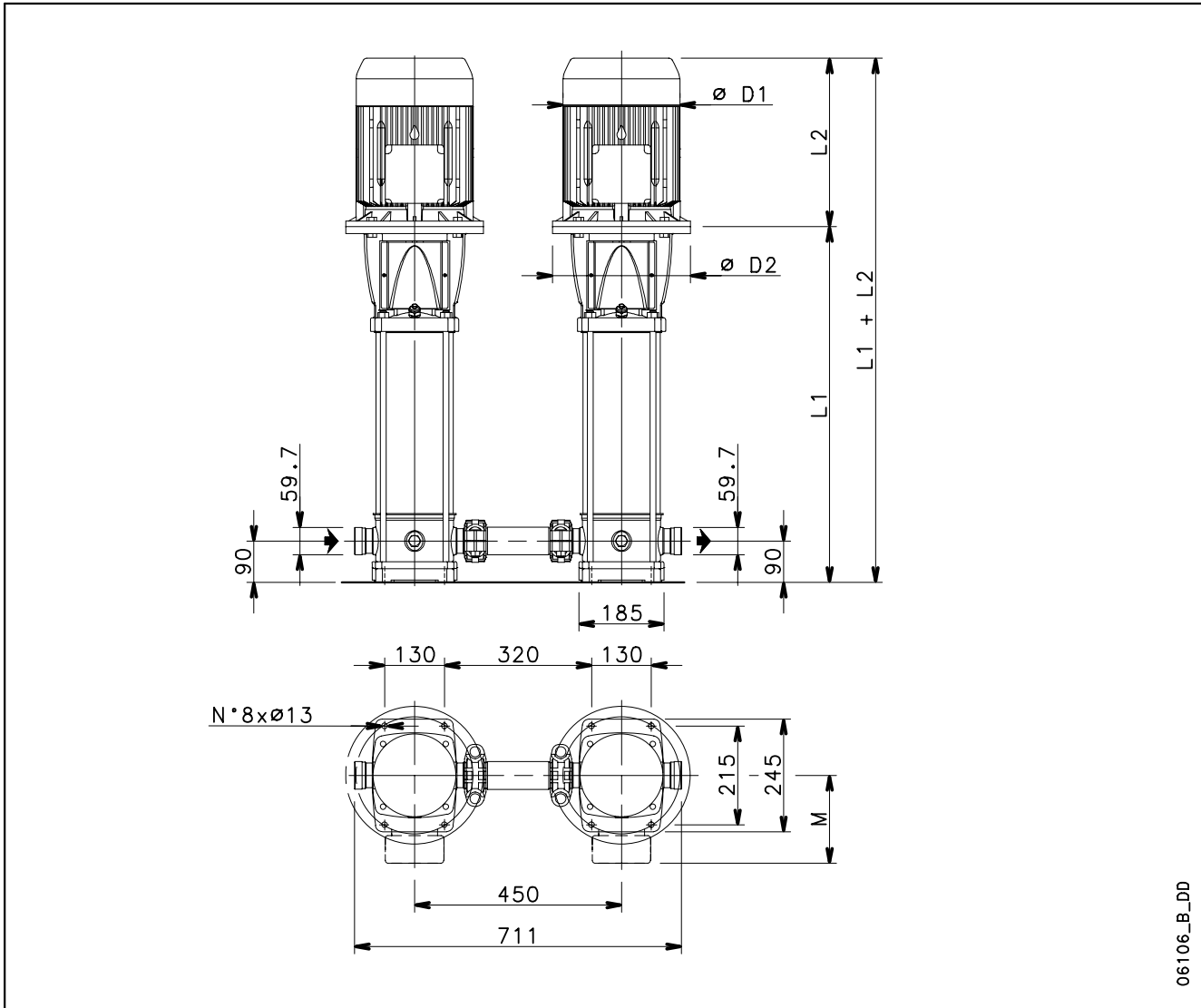

06106_B_DD

PUMP TYPE	MOTOR		DIMENSIONS (mm)					WEIGHT (Kg)	
	kW	Size	L1	L2	M	D1	D2	PUMP	ELECTRIC PUMP
10SV08P..	5,5	132	646	375	168	214	300	28,6	66
10SV09P..	7,5	132	678	367	191	256	300	29,8	86
10SV10P..	7,5	132	710	367	191	256	300	30,9	87
10SV11P..	7,5	132	742	367	191	256	300	32	88
10SV13P..	11	160	836	428	191	256	350	37,1	108

Dimensions and weights are related to one electric pump.

10sv-p-2p60-en_c_td

**10SV..P SERIES - HIGH PRESSURE
OPERATING CHARACTERISTICS AT 60 Hz, 2-POLE**

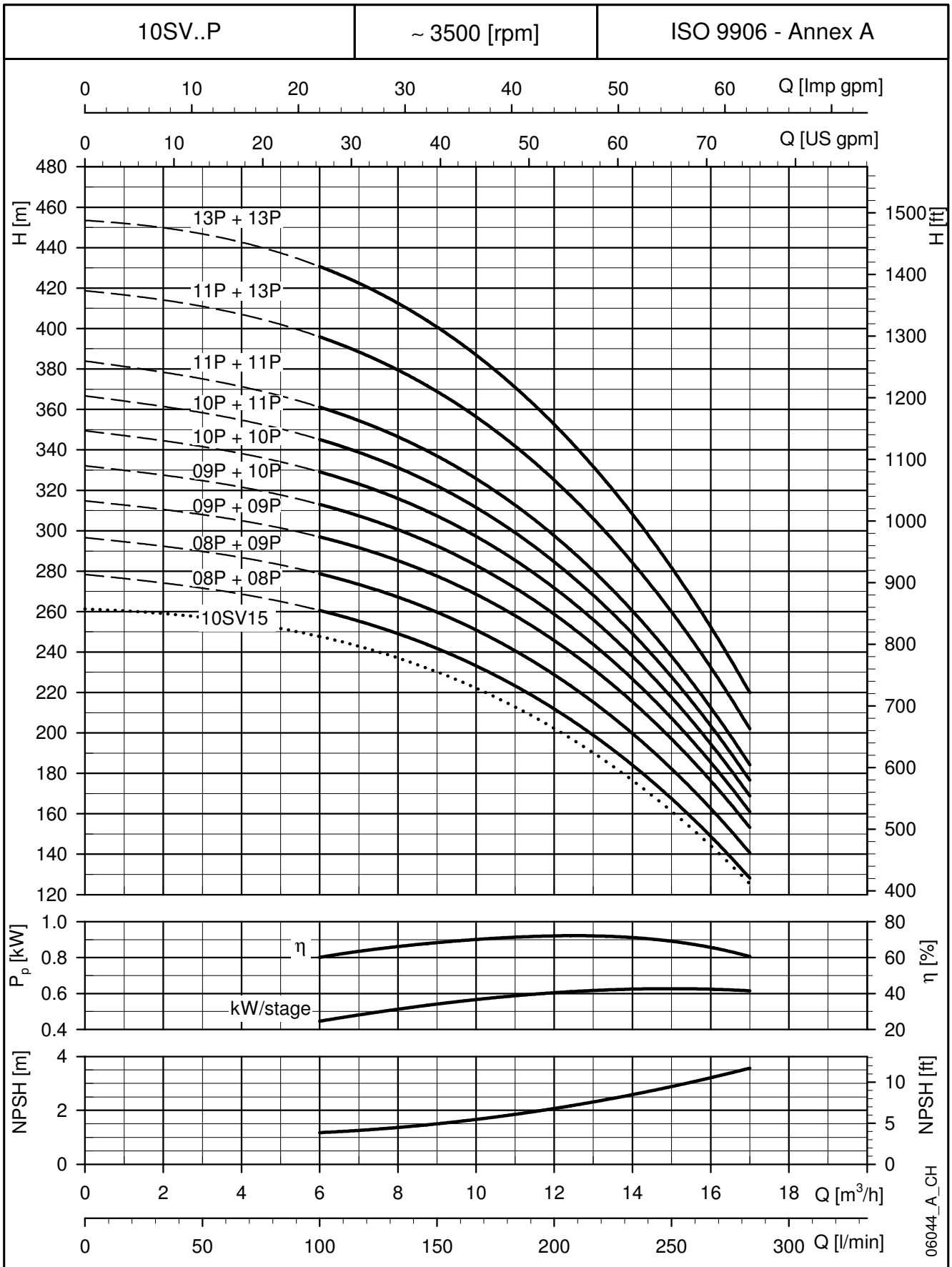

HIGH PRESSURE 60HZ

These performances are valid for liquids with density $\rho = 1.0 \text{ Kg/dm}^3$ and kinematic viscosity $\nu = 1 \text{ mm}^2/\text{sec}$.

15SV..P SERIES - HIGH PRESSURE DIMENSIONS AND WEIGHTS AT 60 Hz, 2-POLE

HIGH PRESSURE 60Hz

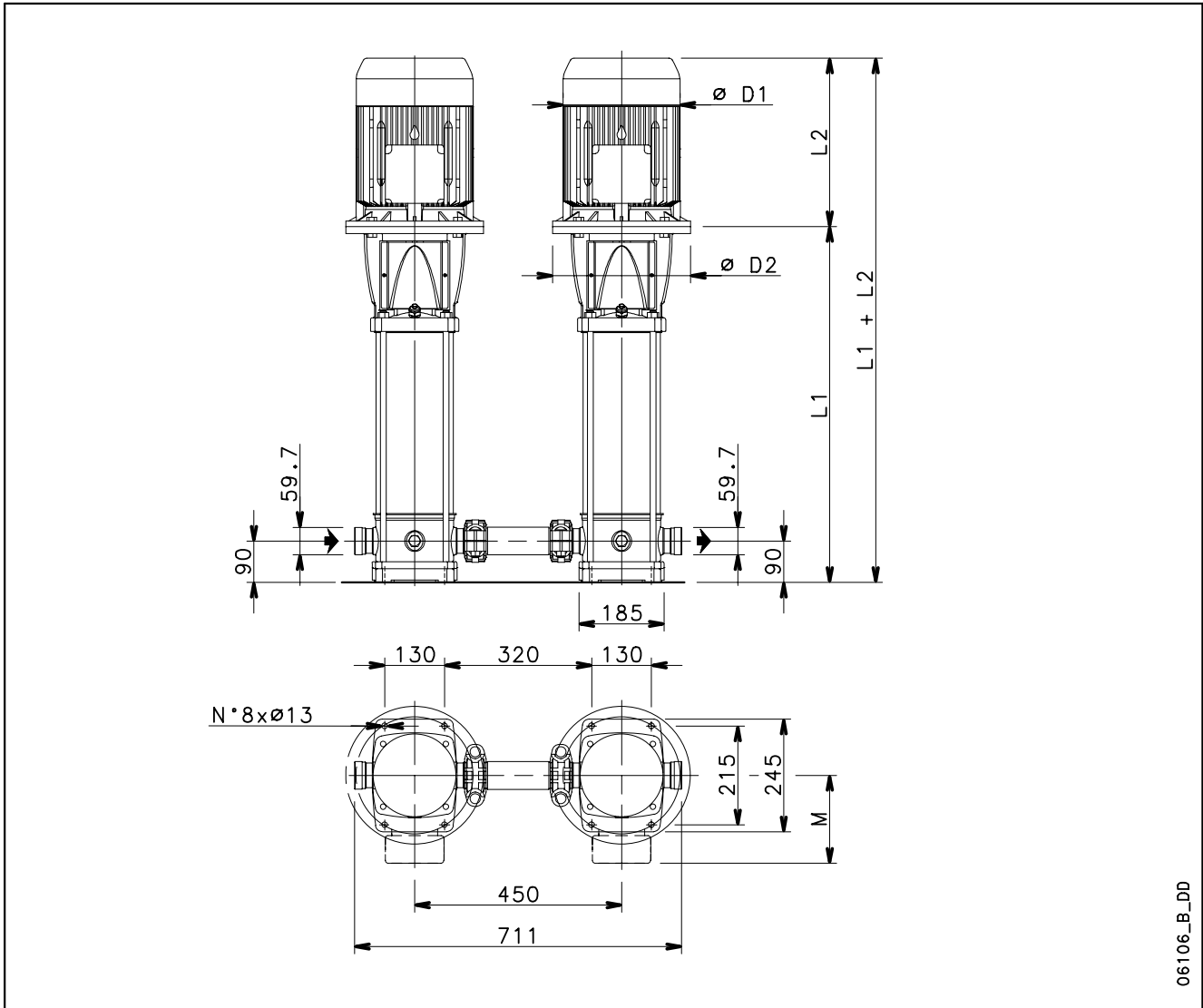

06106_B_DD

PUMP TYPE	MOTOR		DIMENSIONS (mm)					WEIGHT (Kg)	
	kW	Size	L1	L2	M	D1	D2	PUMP	ELECTRIC PUMP
15SV06P..	11	160	708	428	191	256	350	32,5	103
15SV07P..	11	160	756	428	191	256	350	34,5	105
15SV08P..	15	160	804	494	240	313	350	36	139
15SV09P..	15	160	852	494	240	313	350	37,5	140
15SV10P..	15	160	900	494	240	313	350	39,5	141
15SV11P..	18,5	160	948	494	240	313	350	41	152

Dimensions and weights are related to one electric pump.

15sv-p-2p60-en_b_td

**15SV.P SERIES - HIGH PRESSURE
OPERATING CHARACTERISTICS AT 60 Hz, 2-POLE**

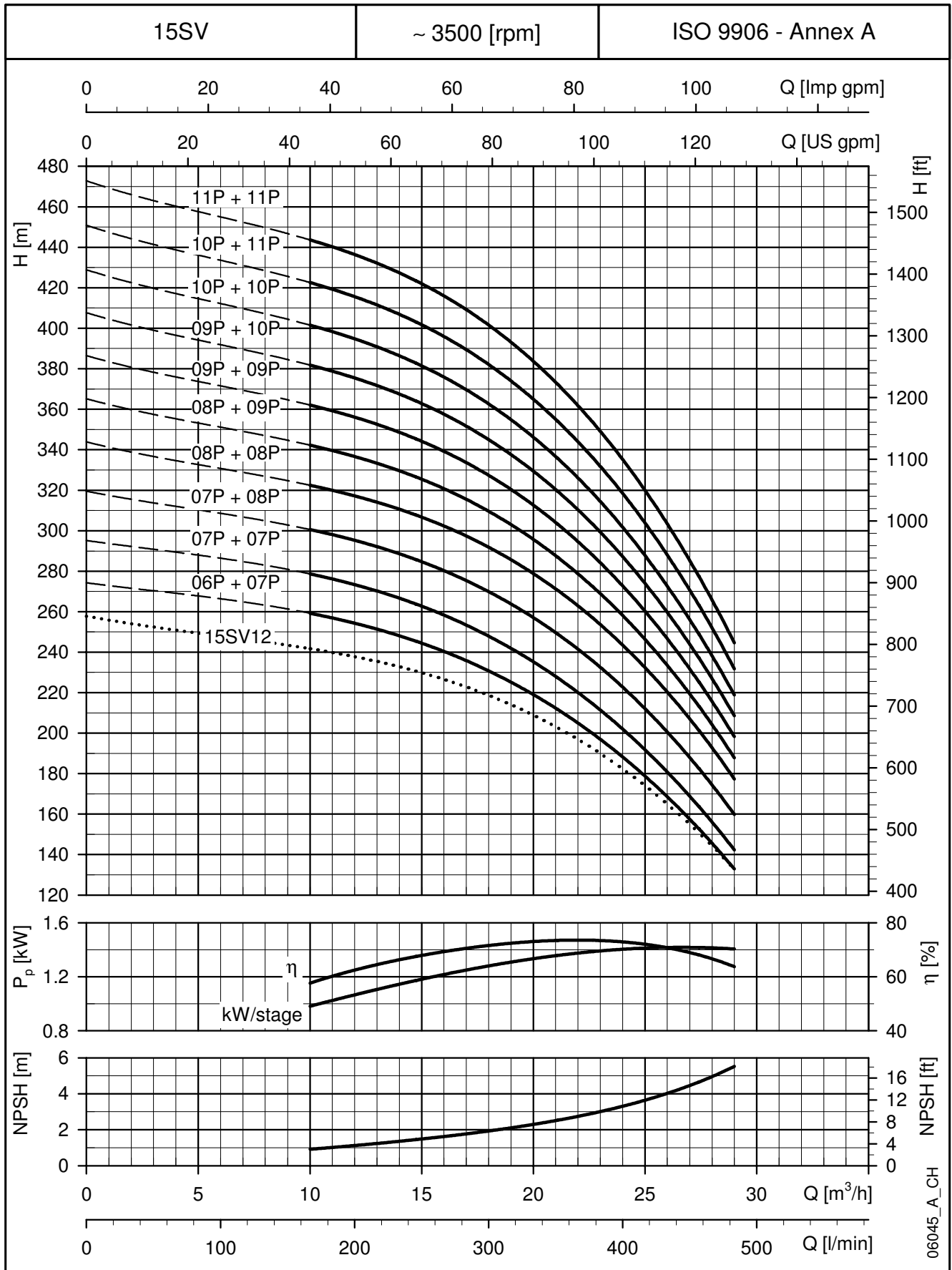

HIGH PRESSURE 60HZ

These performances are valid for liquids with density $\rho = 1.0 \text{ Kg/dm}^3$ and kinematic viscosity $\nu = 1 \text{ mm}^2/\text{sec}$.

22SV..P SERIES - HIGH PRESSURE DIMENSIONS AND WEIGHTS AT 60 Hz, 2-POLE

HIGH PRESSURE 60Hz

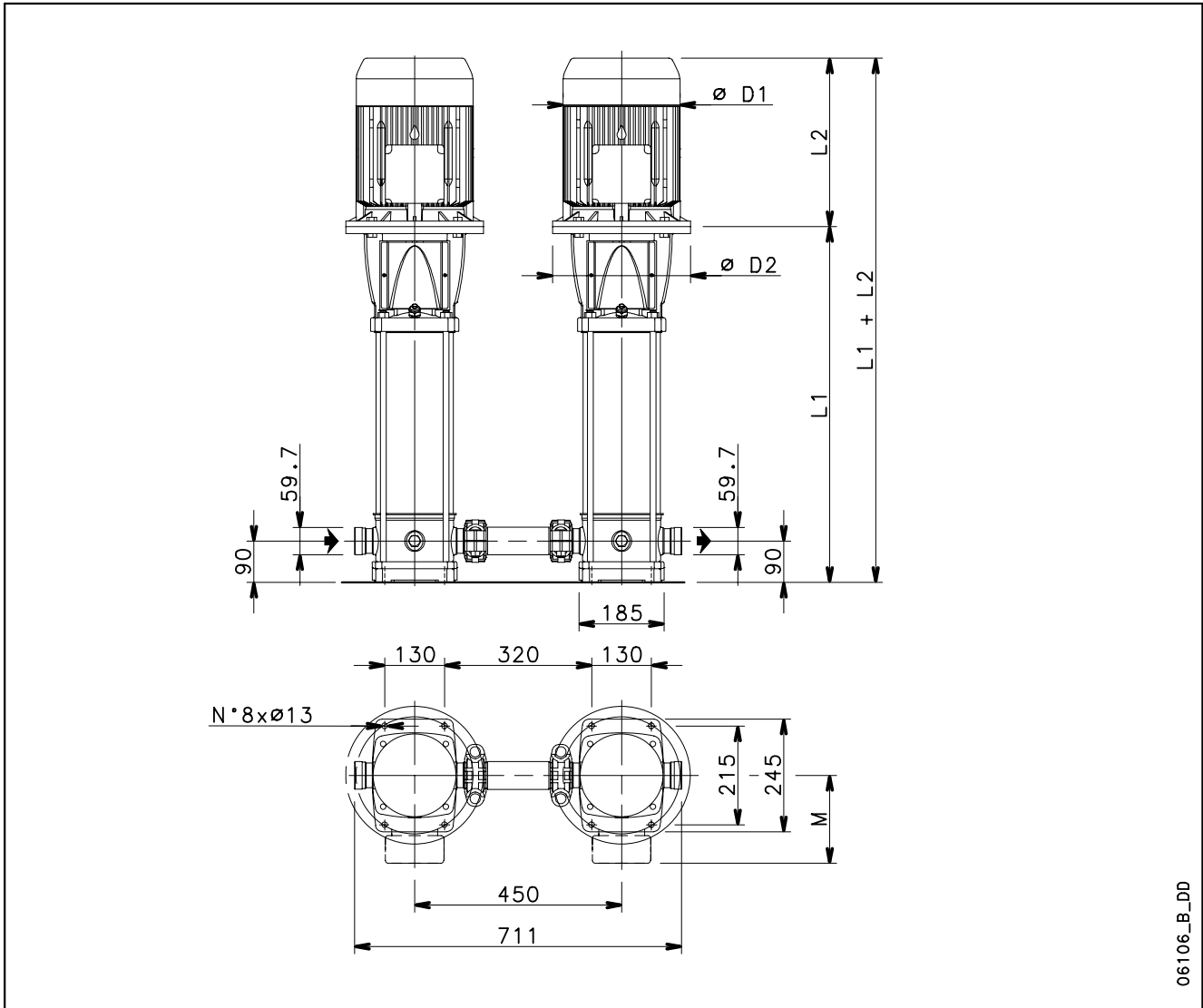

06106_B_DD

PUMP TYPE	MOTOR		DIMENSIONS (mm)					WEIGHT (Kg)	
	kW	Size	L1	L2	M	D1	D2	PUMP	ELECTRIC PUMP
22SV05P..	11	160	660	428	191	256	350	31,5	102
22SV06P..	11	160	708	428	191	256	350	33	104
22SV07P..	15	160	756	494	240	313	350	35	137
22SV08P..	15	160	804	494	240	313	350	36,5	139
22SV09P..	18,5	160	852	494	240	313	350	38	149
22SV10P..	18,5	160	900	494	240	313	350	39,5	151

Dimensions and weights are related to one electric pump.

22sv-p-2p60-en_b_td

**22SV..P SERIES - HIGH PRESSURE
OPERATING CHARACTERISTICS AT 60 Hz, 2-POLE**

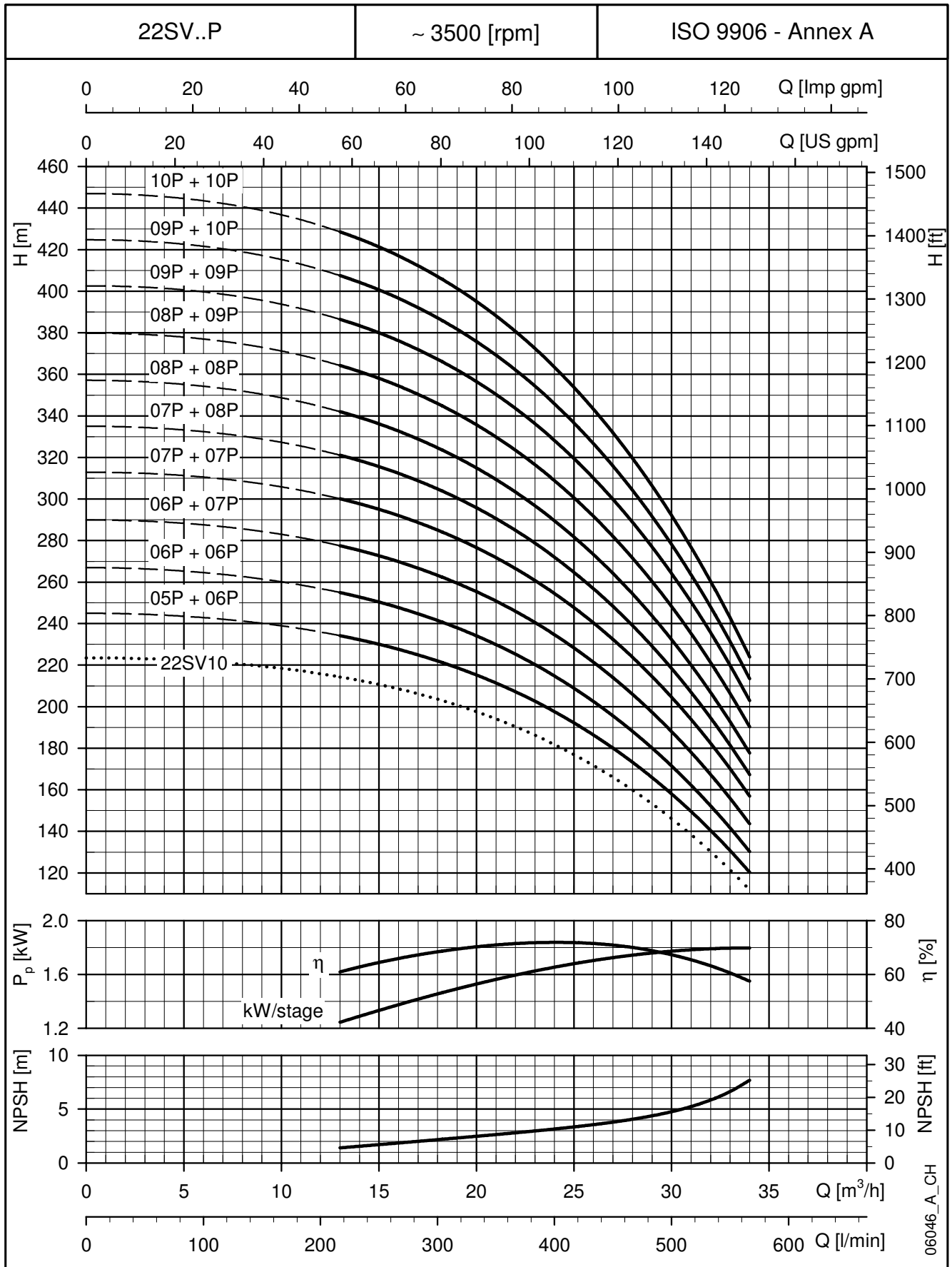

HIGH PRESSURE 60HZ

These performances are valid for liquids with density $\rho = 1.0 \text{ Kg/dm}^3$ and kinematic viscosity $\nu = 1 \text{ mm}^2/\text{sec}$.

33SV..P SERIES - HIGH PRESSURE DIMENSIONS AND WEIGHTS AT 60 Hz, 2-POLE

HIGH PRESSURE 60Hz

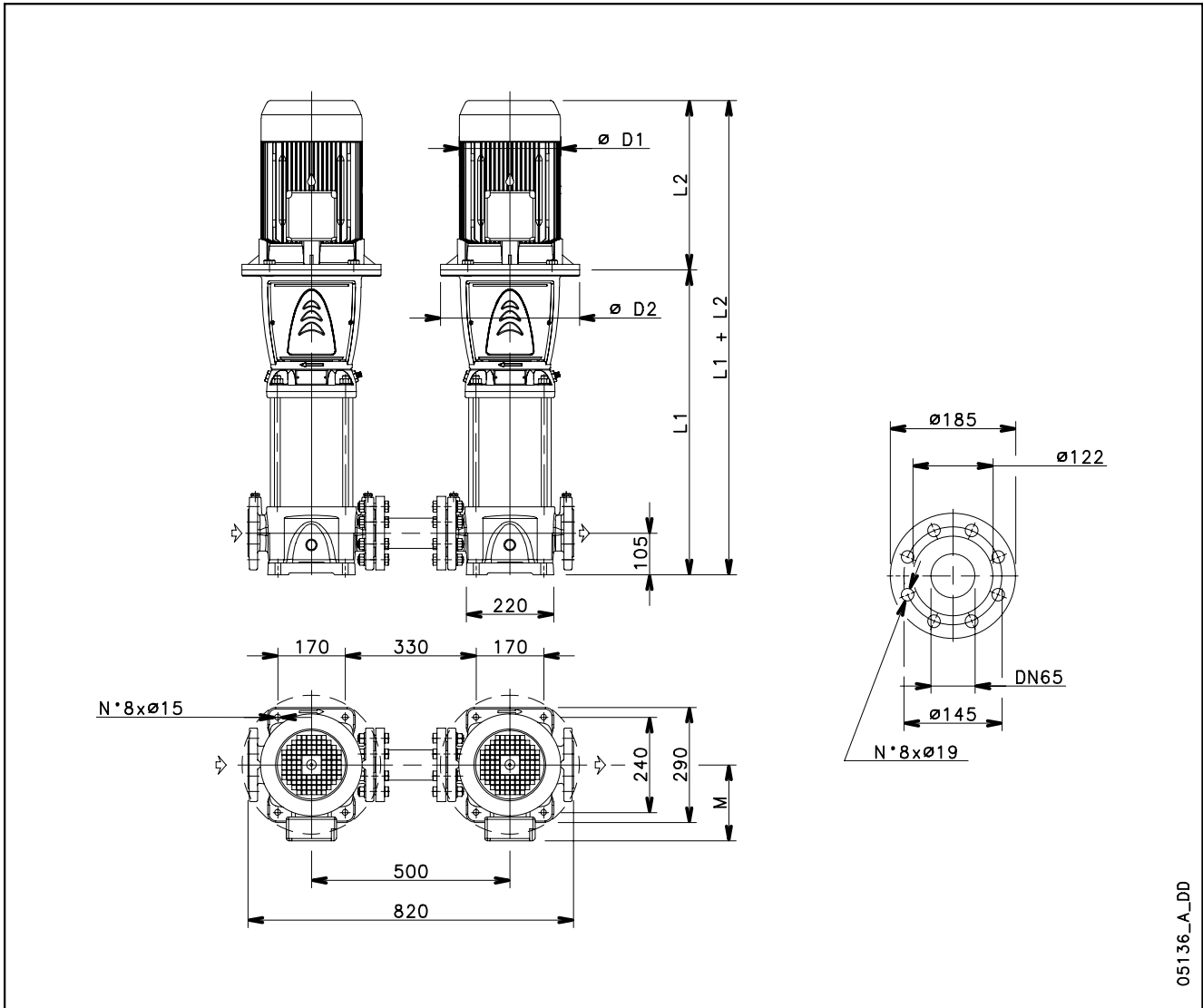

05136_A_DD

PUMP TYPE	MOTOR		DIMENSIONS (mm)					WEIGHT (Kg)	
	kW	Size	L1	L2	M	D1	D2	PUMP	ELECTRIC PUMP
33SV5/2AP..	18,5	160	844	494	240	313	350	80	191
33SV6/2AP..	22	180	919	494	240	313	350	86	208
33SV7/2AP..	30	200	994	657	317	402	400	96	322
33SV7P..	30	200	994	657	317	402	400	96	322

Dimensions and weights are related to one electric pump.

33sv-p-2p60-en_b_td

33SV..P SERIES - HIGH PRESSURE OPERATING CHARACTERISTICS AT 60 Hz, 2-POLE

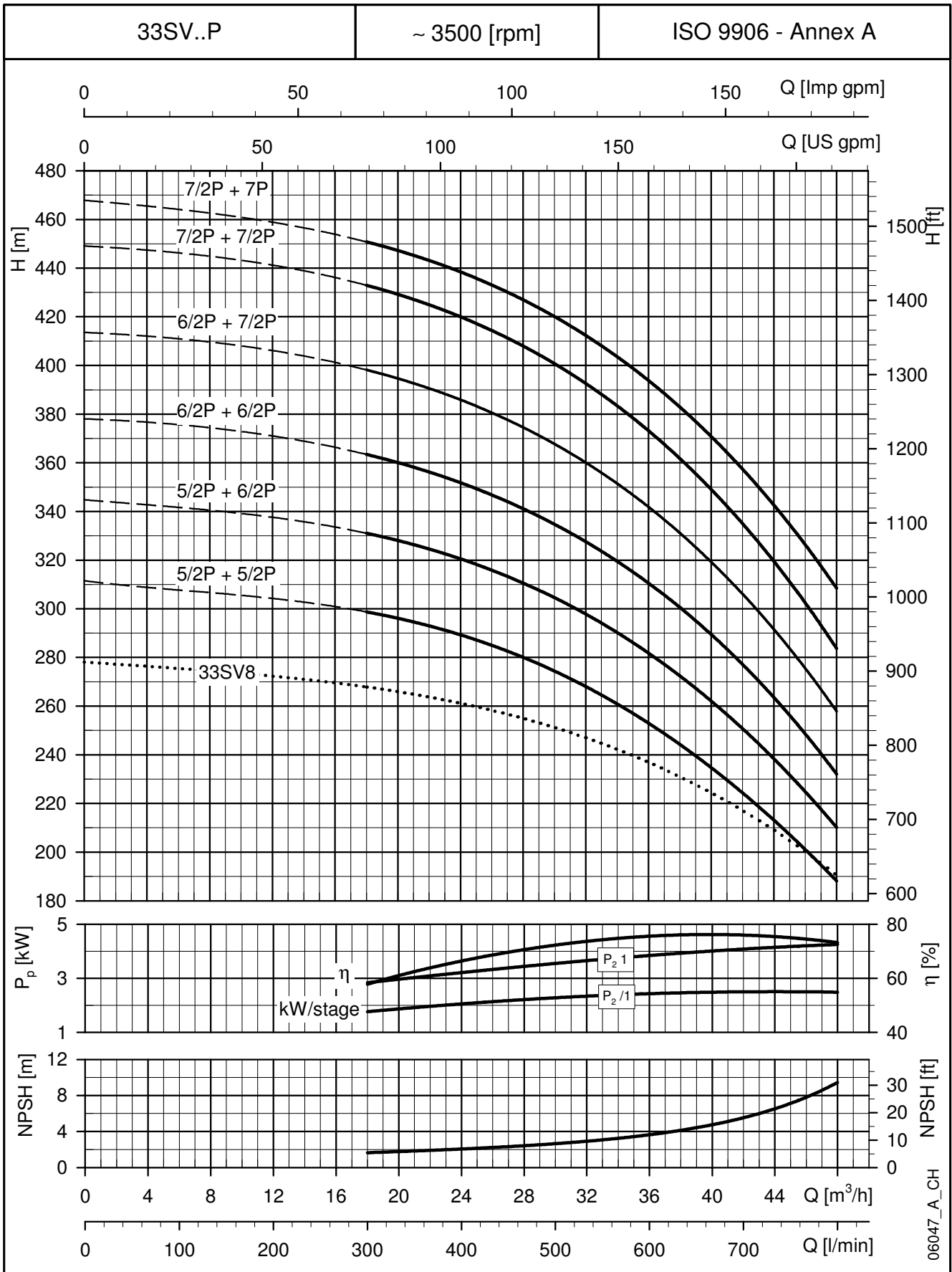

HIGH PRESSURE 60HZ

These performances are valid for liquids with density $\rho = 1.0 \text{ Kg/dm}^3$ and kinematic viscosity $\nu = 1 \text{ mm}^2/\text{sec}$.

**46SV..P SERIES - HIGH PRESSURE
DIMENSIONS AND WEIGHTS AT 60 Hz, 2-POLE**

**HIGH
PRESSURE
60Hz**

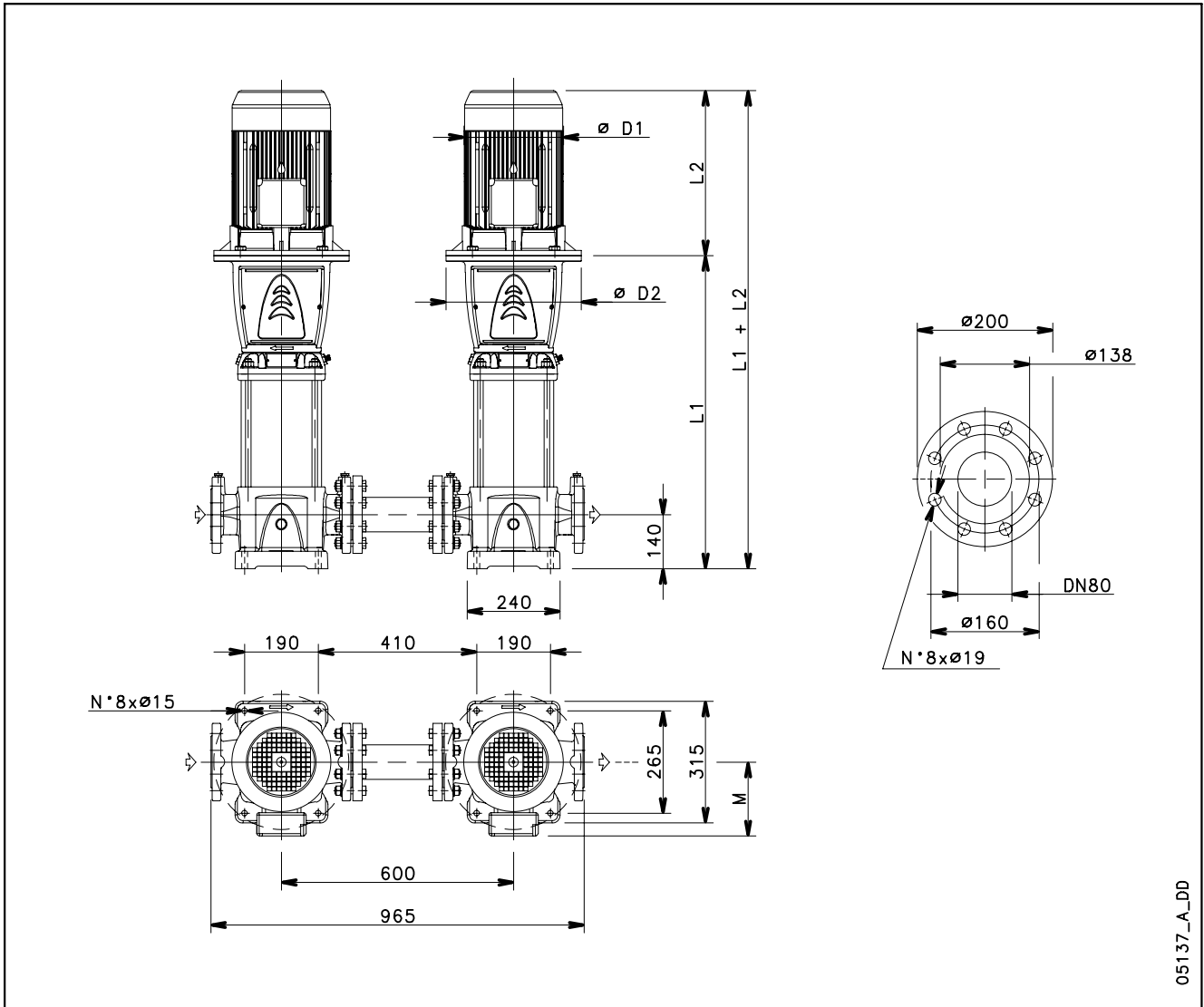

05137_A_DD

PUMP TYPE	MOTOR		DIMENSIONS (mm)					WEIGHT (Kg)	
	kW	Size	L1	L2	M	D1	D2	PUMP	ELECTRIC PUMP
46SV4P..	30	200	809	657	317	402	400	88	314
46SV5/1AP..	30	200	884	657	317	402	400	93	319
46SV6/2AP..	37	200	959	657	317	402	400	98	353
46SV6P..	37	200	959	657	317	402	400	98	353

Dimensions and weights are related to one electric pump.

46sv-p-2p60-en_b_td

46SV..P SERIES - HIGH PRESSURE OPERATING CHARACTERISTICS AT 60 Hz, 2-POLE

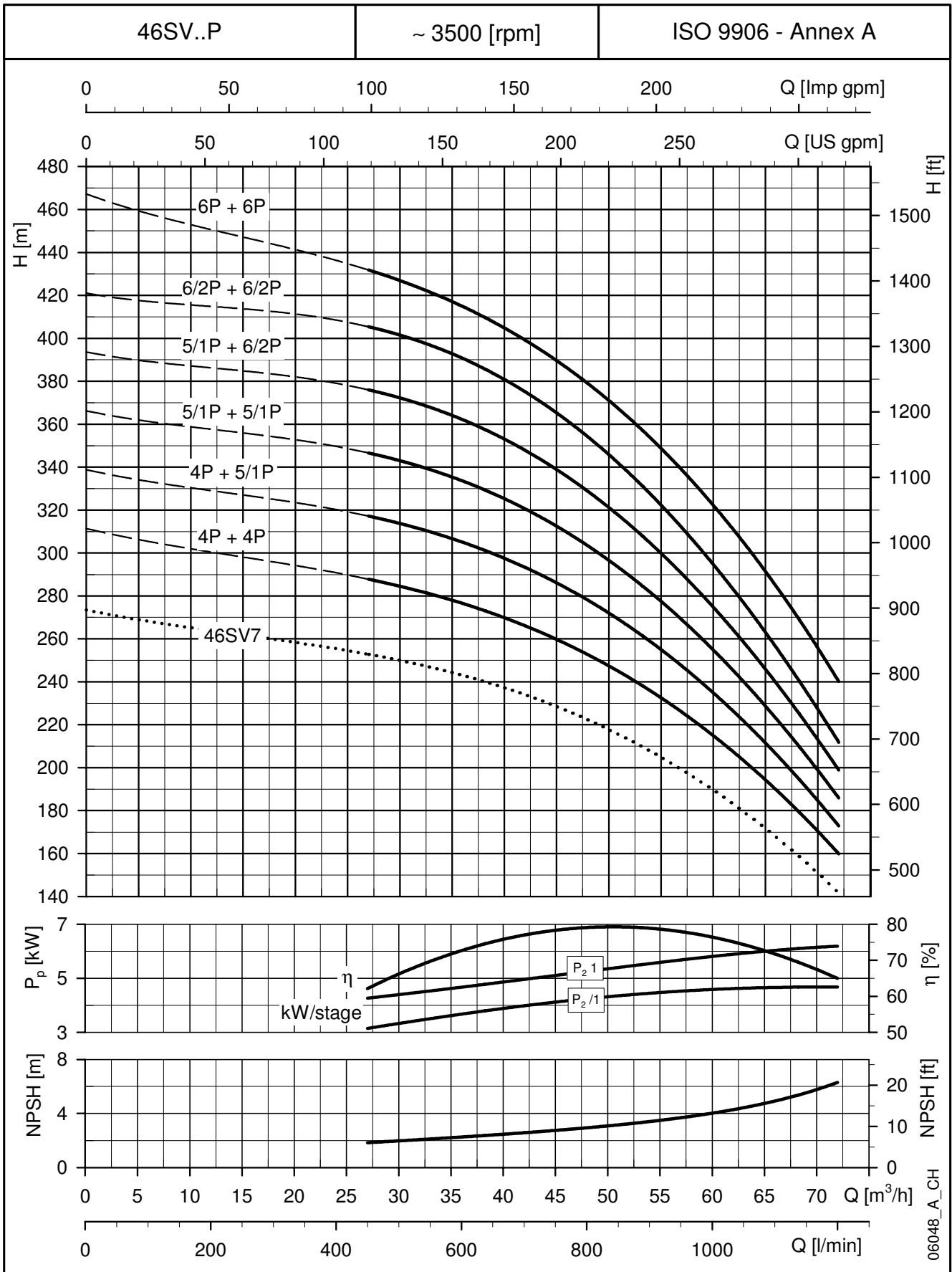

These performances are valid for liquids with density $\rho = 1.0 \text{ Kg/dm}^3$ and kinematic viscosity $\nu = 1 \text{ mm}^2/\text{sec}$.

**66SV..P SERIES - HIGH PRESSURE
DIMENSIONS AND WEIGHTS AT 60 Hz, 2-POLE**

HIGH PRESSURE 60Hz

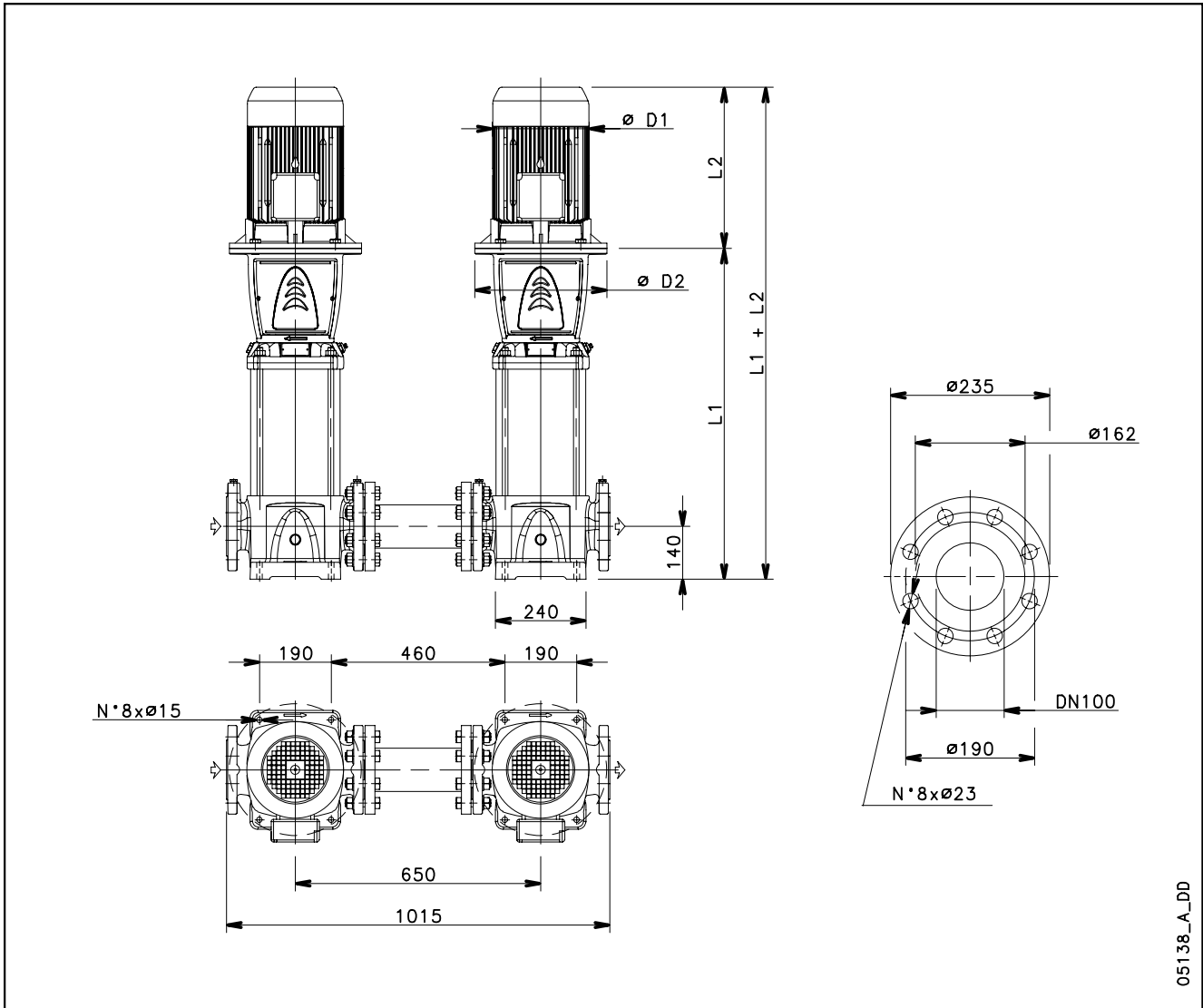

05138_A_DD

PUMP TYPE	MOTOR		DIMENSIONS (mm)					WEIGHT (Kg)	
	kW	Size	L1	L2	M	D1	D2	PUMP	ELECTRIC PUMP
66SV3/1AP..	30	200	789	657	317	402	400	97	323
66SV4/2AP..	37	200	879	657	317	402	400	104	359
66SV4P..	37	200	879	657	317	402	400	106	361
66SV5/2AP..	45	250	969	746	384	455	450	116	472
66SV5P..	45	250	969	746	384	455	450	116	472

Dimensions and weights are related to one electric pump.

66sv-p-2p60-en_b_td

**66SV..P SERIES - HIGH PRESSURE
OPERATING CHARACTERISTICS AT 60 Hz, 2-POLE**

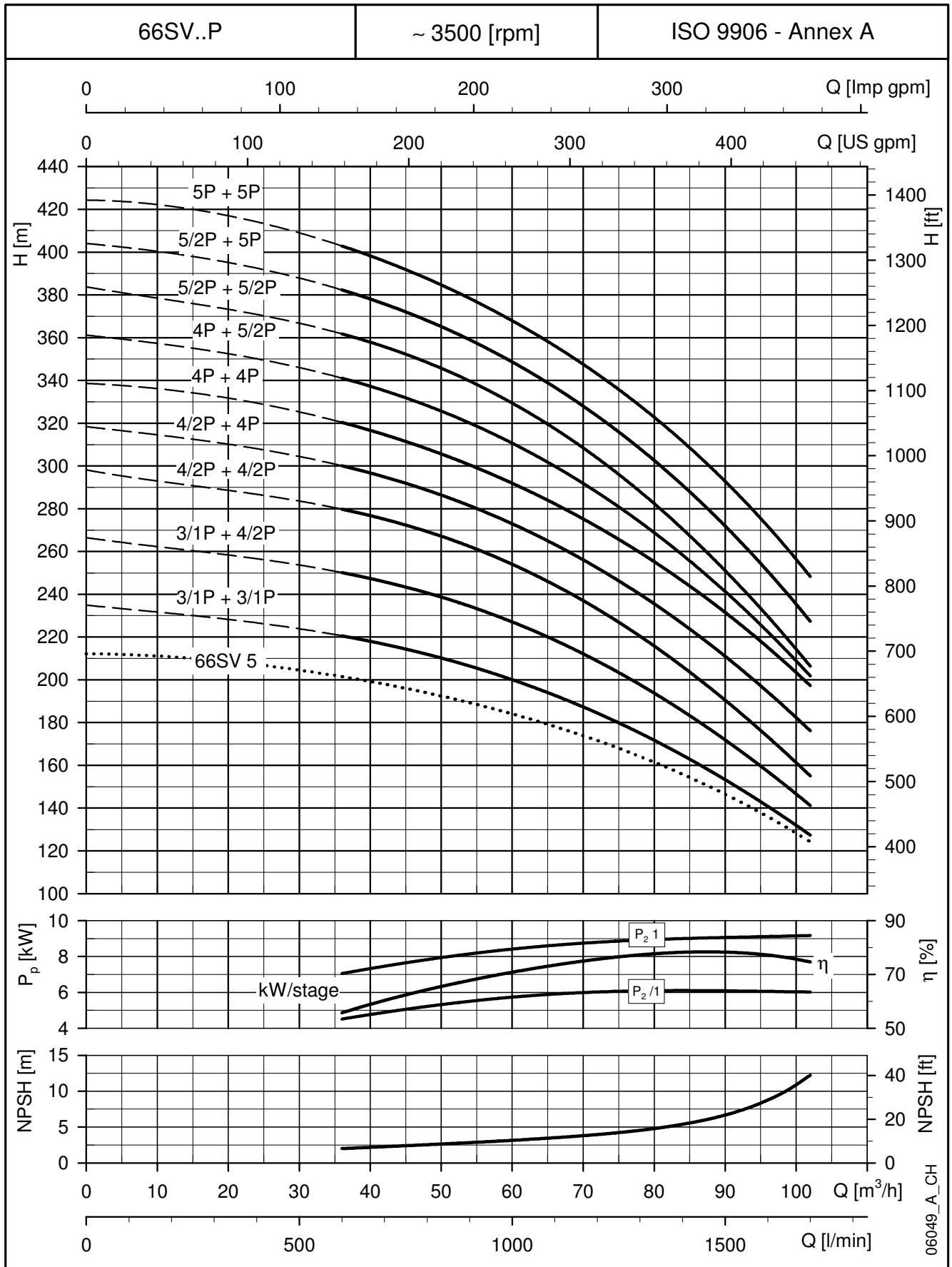

These performances are valid for liquids with density $\rho = 1.0 \text{ Kg/dm}^3$ and kinematic viscosity $\nu = 1 \text{ mm}^2/\text{sec}$.

92SV..P SERIES - HIGH PRESSURE DIMENSIONS AND WEIGHTS AT 60 Hz, 2-POLE

HIGH PRESSURE 60Hz

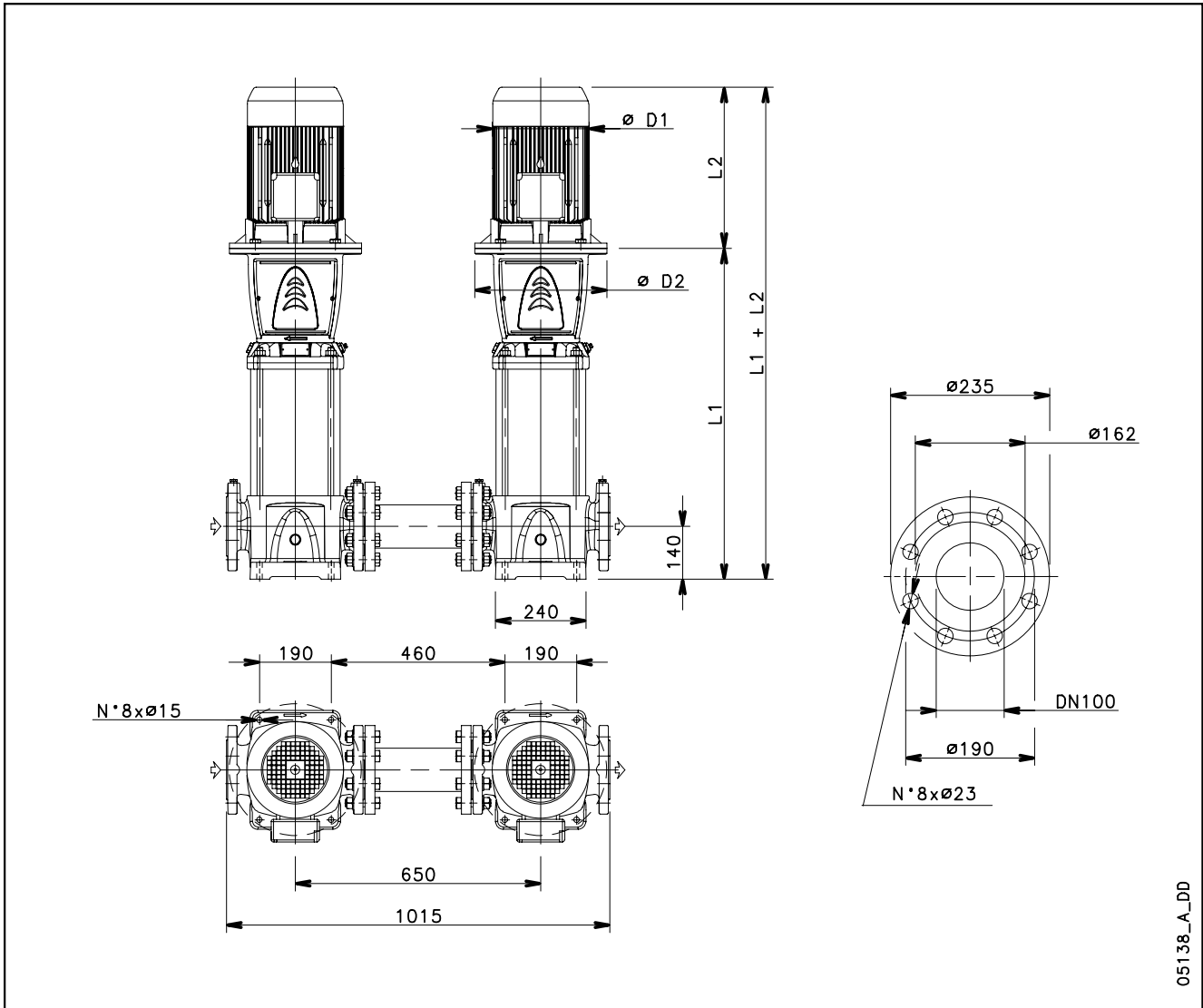

05138_A_DD

PUMP TYPE	MOTOR		DIMENSIONS (mm)					WEIGHT (Kg)	
	kW	Size	L1	L2	M	D1	D2	PUMP	ELECTRIC PUMP
92SV2P..	30	200	699	657	317	402	400	91	317
92SV3/2AP..	37	200	789	657	317	402	400	97	352
92SV3/1AP..	37	200	789	657	317	402	400	97	352
92SV3P..	45	250	789	746	384	455	450	100	456

Dimensions and weights are related to one electric pump.

92sv-p-2p60-en_b_td

92SV..P SERIES - HIGH PRESSURE OPERATING CHARACTERISTICS AT 60 Hz, 2-POLE

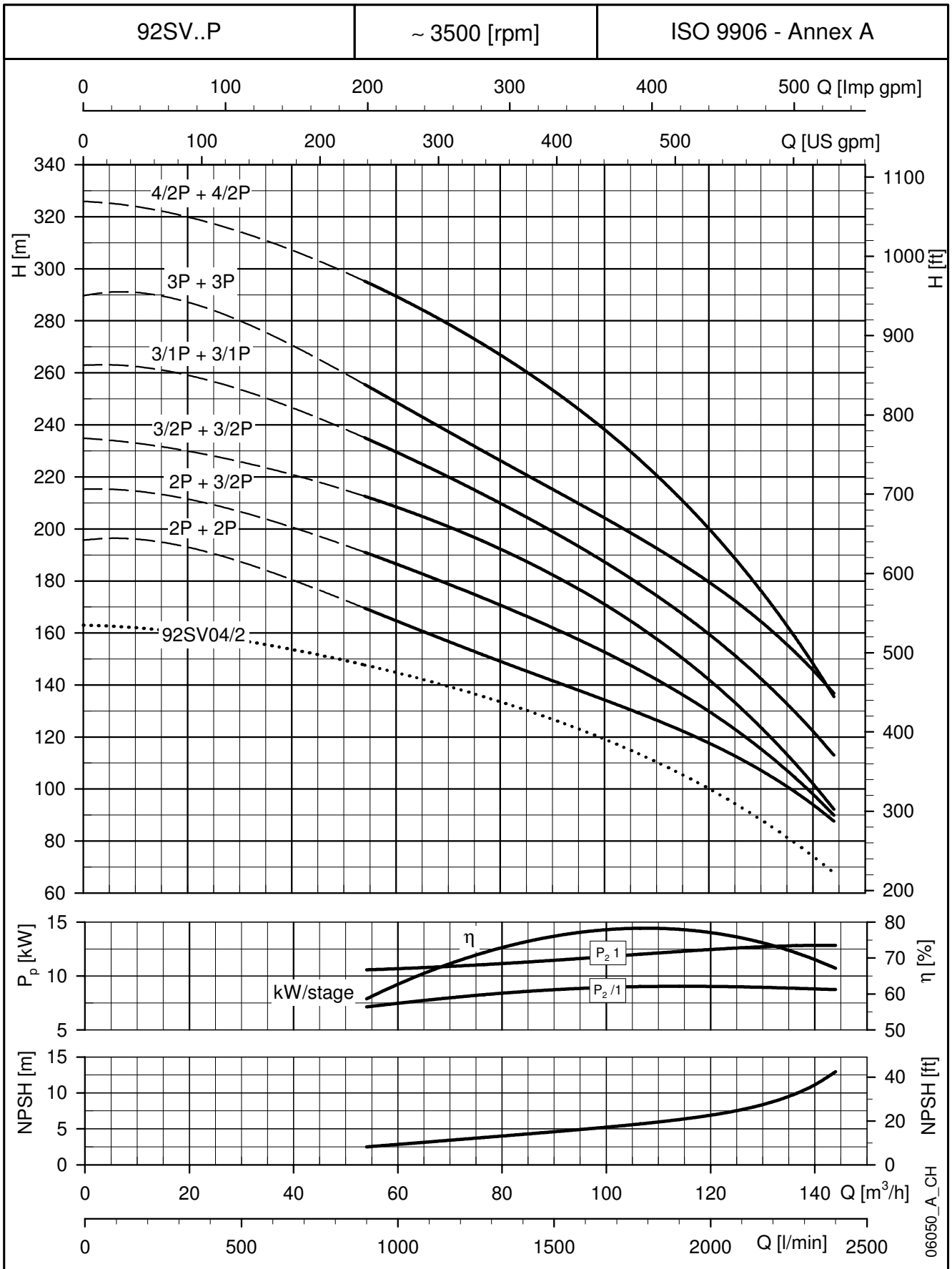

HIGH PRESSURE 60HZ

These performances are valid for liquids with density $\rho = 1.0 \text{ Kg/dm}^3$ and kinematic viscosity $\nu = 1 \text{ mm}^2/\text{sec}$.

**125SV..P SERIES - HIGH PRESSURE
DIMENSIONS AND WEIGHTS AT 60 Hz, 2-POLE**

**HIGH
PRESSURE
60Hz**

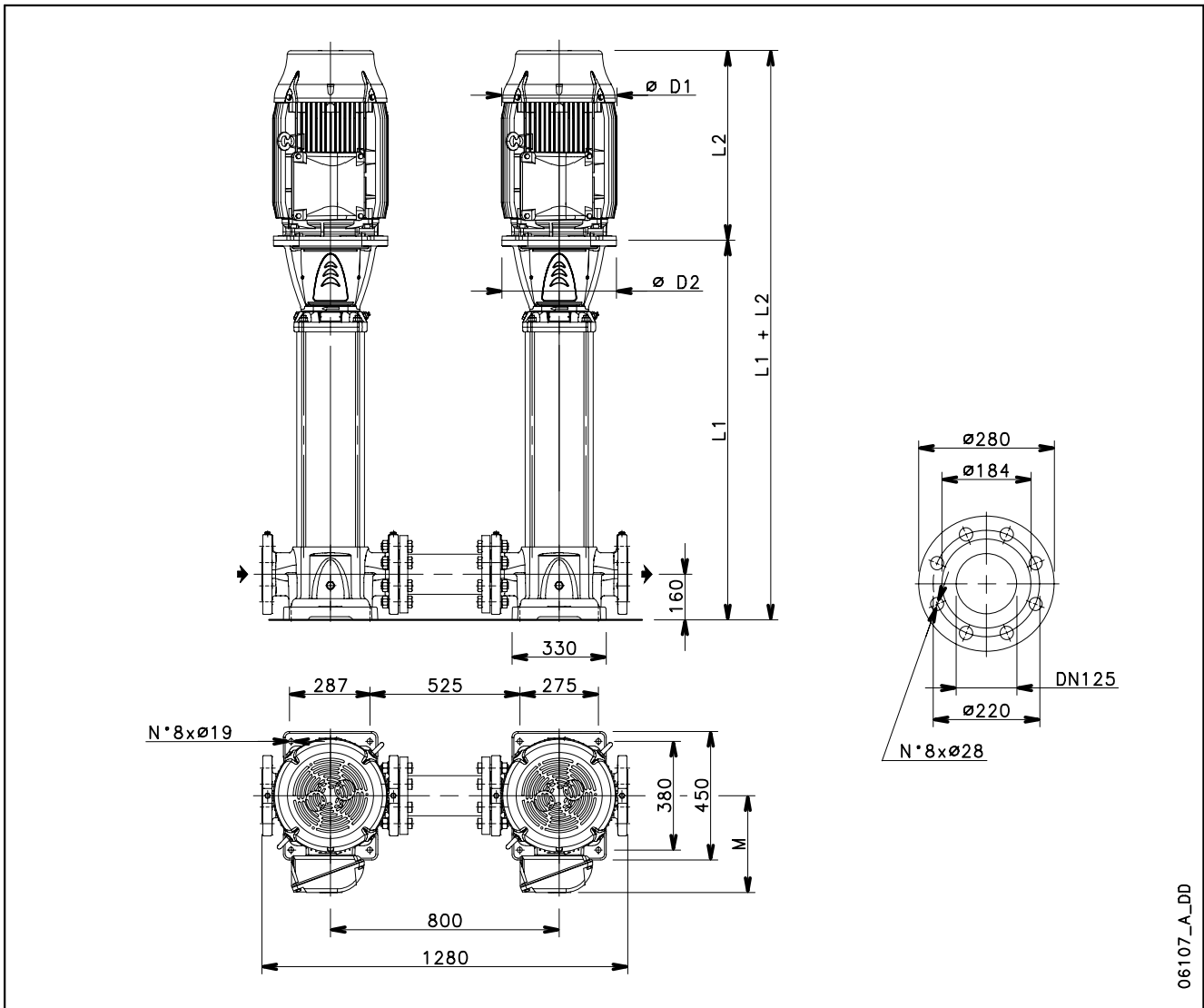

06107_A_DD

PUMP TYPE	MOTOR		DIMENSIONS (mm)					WEIGHT (Kg)	
	kW	Size	L1	L2	M	D1	D2	PUMP	ELECTRIC PUMP
125SV3/3BP..	30	200	1028	657	317	402	400	155	369
125SV3P..	37	200	1028	657	317	402	400	156	388
125SV4/4AP..	45	225	1178	746	384	455	450	172	534
125SV5/5AP..	55	250	1358	825	402	486	550	198	623

Dimensions and weights are related to one electric pump.

125sv-p-2p60-en_b_td

125SV..P SERIES - HIGH PRESSURE OPERATING CHARACTERISTICS AT 60 Hz, 2-POLE

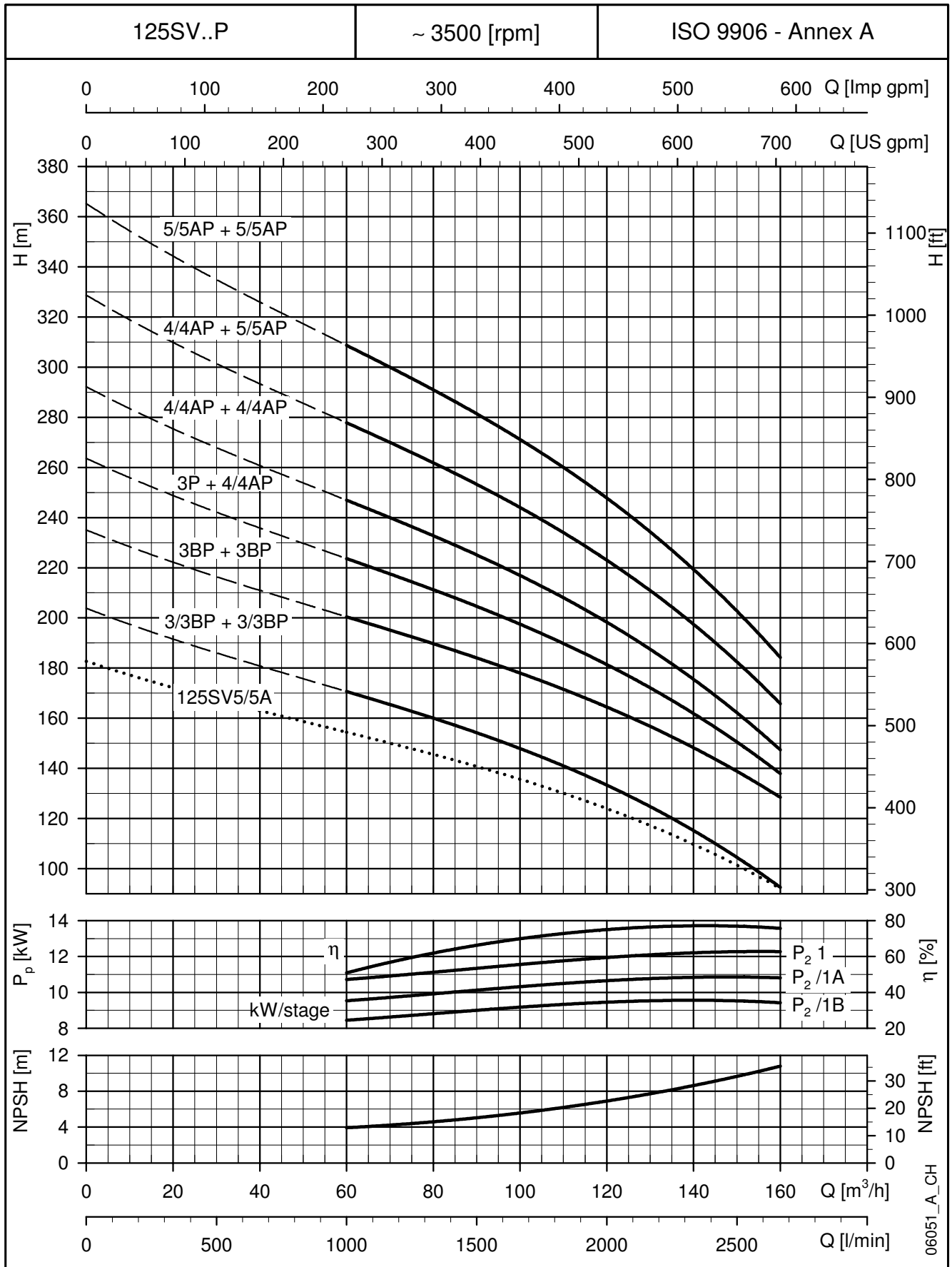

HIGH PRESSURE 60HZ

These performances are valid for liquids with density $\rho = 1.0 \text{ Kg/dm}^3$ and kinematic viscosity $\nu = 1 \text{ mm}^2/\text{sec}$.

LOW NPSH (50/60 Hz)

e-SV™ SERIES - LOW NPSH 50/60 Hz

Background and context

In industrial applications, often pumps are exposed to heavy duty installations and conditions, such as pumping high temperature liquids (boiler-feed), poor inlet pressure conditions or high flow rate applications. In these cases, constant and durable pump operation is often compromised by cavitation. Therefore Lowara has developed e-SV Low NPSH versions: a pump which delivers a definitive and valuable solution to solve cavitation issues in installation.

Benefits of e-SV™ Low NPSH

Consistent operation: the special design of the first initial stage together with a specific impeller design allows e-SV™ Low NPSH versions to improve its suction capacity. Even in critical suction conditions, the pump is able to deliver consistent and constant operation on the whole application range.

Long lasting performances: e-SV™ Low NPSH design ensures consistency in its operation. The specific design of e-SV™ Low NPSH versions saves the pump of the cavitation: the components in the pump are not submitted to stress, decreasing the need of repetitive maintenance and reducing the life cycle cost of the pump.

Easy installation: e-SV™ Low NPSH versions is easy to install and allows saving space. Where traditional pumps will need to have a tank to facilitate the suction conditions, the specific design of e-SV™ Low NPSH version allows installing the pumps without any additional accessories on the suction side. A compact design where reduced spaces are favored.

Code identification

e-SV™ Low NPSH design is identified with a "L" in the product codification of the whole e-SV™ range.

Example: 3SV13FL015T

L = Low NPSH version.



Special features / product benefits

- **Specific first stage design** to maximize suction conditions.
- **Easy-to-replace standard mechanical seal** (EN12756) on all models from 5,5 kW for easy maintenance **without removing the motor.**
- **Hard material intermediate bush bearing** (Tungsten Carbide) to improve life and ability to withstand heavy duty application on all sizes.
- **Balanced impeller design** (patent pending) to reduce axial thrust for longer standard motor bearing life.
- **Wide range of sizes to cover all requested duty points:** from 1SV to 66SV.
- **i-Alert device** to reduce life cycle costs by increasing Mean time between Failures (MTBF).

Special configurations

e-SV™ Low NPSH offers a wide range of configurations:

- Material execution. See Material section.
- Mechanical seal and rubbers options. See Mechanical seal and rubber section.
- Motors options and configuration. See Motor section.
- Hydrovar® drive fitted. See e-SVH – Hydrovar® fitted section.

e-SV™ SERIES - LOW NPSH 50/60 Hz

Technical characteristics - Design

- 1: Specific initial impeller design to maximize suction abilities.
- 2: Specific initial stage design to enhance suction capabilities of the pump.

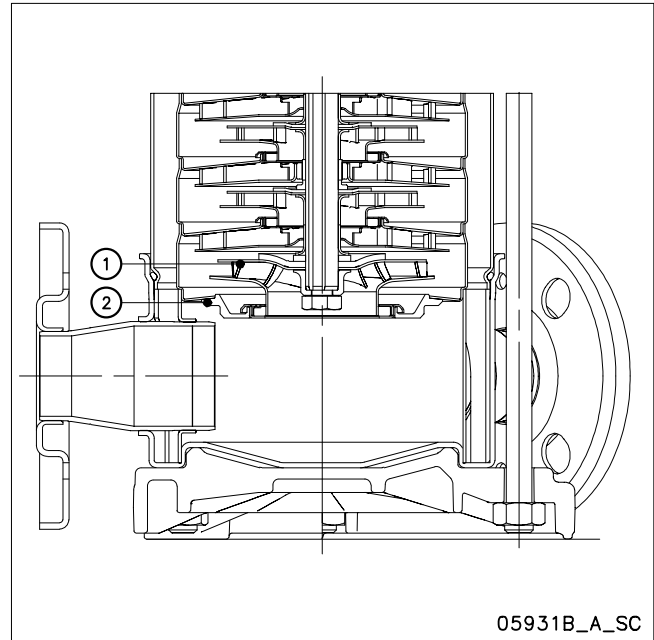

**LOW
NPSH**

TECHNICAL CHARACTERISTICS

L VERSIONS - 50 Hz	1SV	3SV	5SV	10SV	15SV	22SV	33SV	46SV	66SV
Max efficiency flow (m ³ /h)	1,7	3,3	5,9	10,5	18	20,5	33	44	75
Flow range (m ³ /h)	0,7÷2,4	1,2÷4,4	2,4÷8,5	5÷14	8÷24	11÷29	15÷40	22÷60	30÷85
Maximum pressure (bar)	23	25	25	25	25	25	31	32	24
Motor power (kW)	0,37÷2,2	0,37÷3	0,75÷5,5	1,5÷11	3÷15	3÷18,5	5,5÷37	7,5÷45	11÷45
Max η (%) of pump	50	62	67	71	70	71	77	76	78
Standard temperature of pumped liquid (°C)	-30 +120								
Standard ambient temp. (°C)	-15 +40								
Min/max NPSHr value (m)	0,4÷0,6	0,5÷0,9	0,4÷1,5	0,5÷1,3	1÷2	1,1÷2,6	1÷2,4	1,8÷2,5	1,5÷3,3
Material execution	No variation according to e-SV versions: F (AISI 304), G (AISI 304/Ghisa), N (AISI 316)								
Mechanical seal configuration	No variation according to e-SV series								
Flange configuration	Round flange (F, G, N versions)								

svL-50-en_a_tg

L VERSIONS - 60 Hz	1SV	3SV	5SV	10SV	15SV	22SV	33SV	46SV	66SV
Max efficiency flow (m ³ /h)	2,2	3,9	7	12,8	22	25	39	53	85
Flow range (m ³ /h)	0,8÷2,8	1,4÷5,2	3÷10	6÷17	10÷29	13÷34	18÷48	27÷72	36÷102
Maximum pressure (bar)	25	25	25	25	25	22	28	26	20
Motor power (kW)	0,37÷3	0,55÷4	1,1÷7,5	3÷11	4÷18,5	5,5÷22	7,5÷37	15÷45	18,5÷45
Max η (%) of pump	54	63	70	71	70	73	77	76	78
Standard temperature of pumped liquid (°C)	-30 +120								
Standard ambient temp. (°C)	-15 +40								
Min/max NPSHr value (m)	0,5÷0,7	0,8÷1,3	0,9÷2,1	0,8÷1,8	1,3÷2,9	1,6÷3,4	1,3÷3,2	2,2÷3,3	3÷4,3
Material execution	No variation according to e-SV versions: F (AISI 304), G (AISI 304/Ghisa), N (AISI 316)								
Mechanical seal configuration	No variation according to e-SV series								
Flange configuration	Round flange (F, G, N versions)								

svL-60-en_a_tg

1SV..L SERIES - LOW NPSH - 3 TO 15 STAGES DIMENSIONS AND WEIGHTS AT 50 Hz, 2-POLE

LOW
NPSH
50Hz

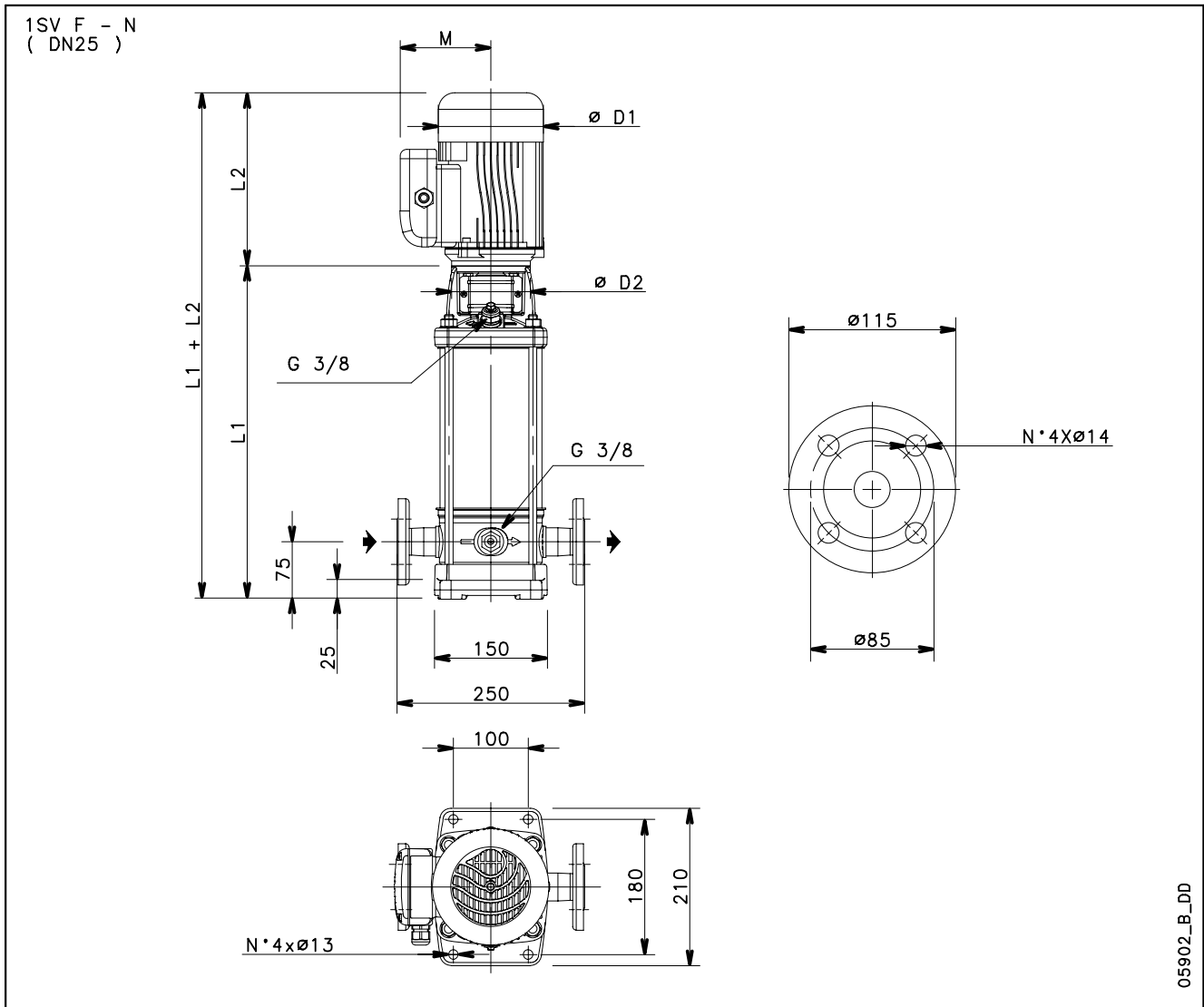

05902_B_DD

PUMP TYPE	MOTOR		DIMENSIONS (mm)								WEIGHT kg	
	kW	SIZE	L1	L2		M		D1		D2	PUMP	ELECTRIC
1SV03..L..	0,37	71	278	209	209	111	111	120	120	105	8,6	13,4
1SV04..L..	0,37	71	298	209	209	111	111	120	120	105	9	13,8
1SV05..L..	0,37	71	318	209	209	111	111	120	120	105	9,4	14,2
1SV06..L..	0,37	71	338	209	209	111	111	120	120	105	9,8	14,6
1SV07..L..	0,37	71	358	209	209	111	111	120	120	105	10,2	14,9
1SV08..L..	0,55	71	378	231	231	121	121	140	140	105	10,5	15,2
1SV09..L..	0,55	71	398	231	231	121	121	140	140	105	10,9	15,6
1SV10..L..	0,55	71	418	231	231	121	121	140	140	105	11,3	16
1SV11..L..	0,55	71	438	231	231	121	121	140	140	105	11,7	16,4
1SV12..L./D	0,75	80	468	226	263	121	129	140	155	120	12,7	22,3
1SV13..L./D	0,75	80	488	226	263	121	129	140	155	120	13,1	22,7
1SV15..L./D	0,75	80	528	226	263	121	129	140	155	120	13,9	23,5

1sv-L1-2p50-en_b_td

1SV..L SERIES - LOW NPSH - 3 TO 15 STAGES
OPERATING CHARACTERISTICS AT 50 Hz, 2-POLE

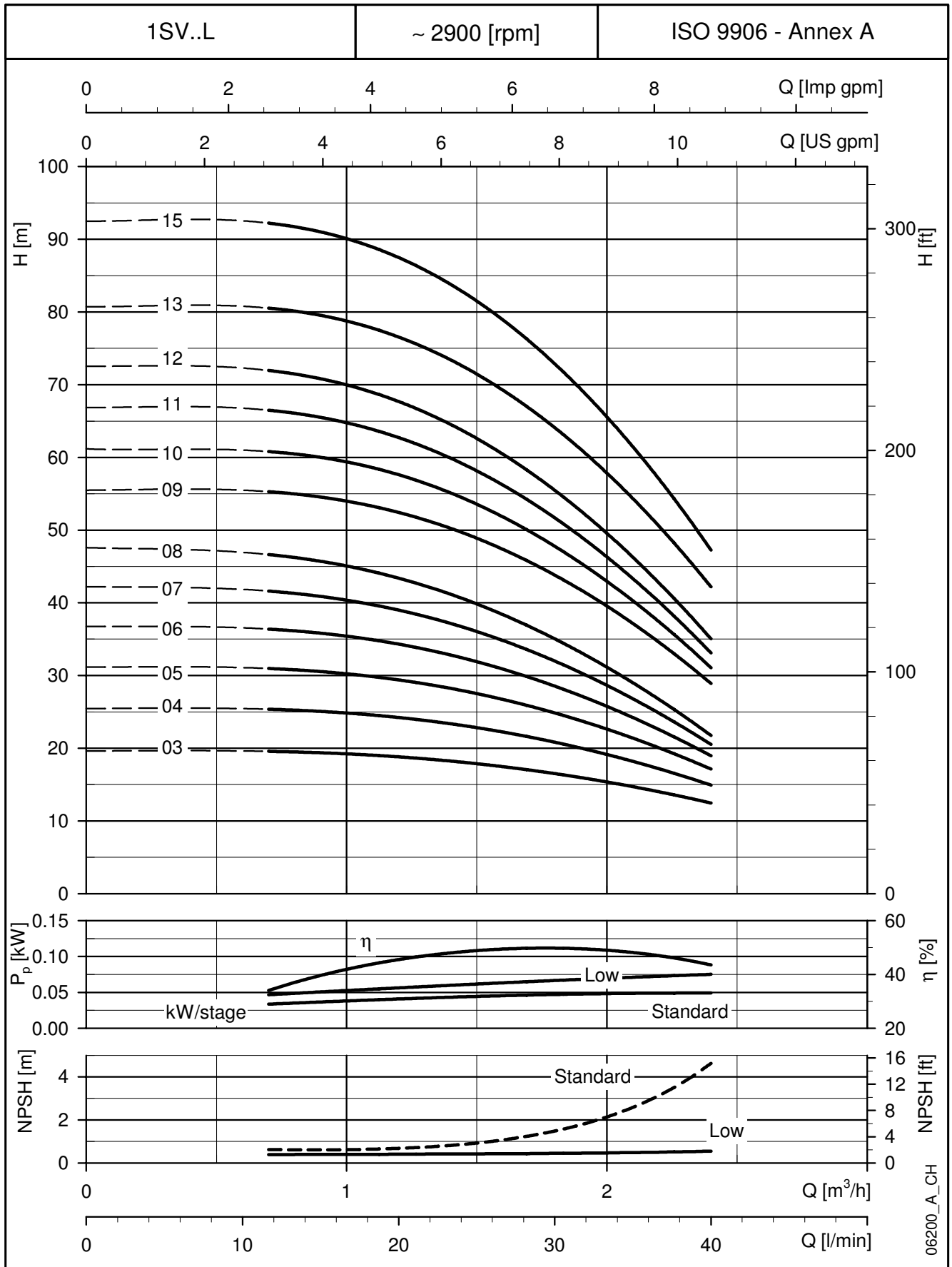

LOW NPSH 50Hz

These performances are valid for liquids with density $\rho = 1.0 \text{ Kg/dm}^3$ and kinematic viscosity $\nu = 1 \text{ mm}^2/\text{sec}$.

**1SV..L SERIES - LOW NPSH - 17 TO 37 STAGES
DIMENSIONS AND WEIGHTS AT 50 Hz, 2-POLE**

**LOW
NPSH
50Hz**

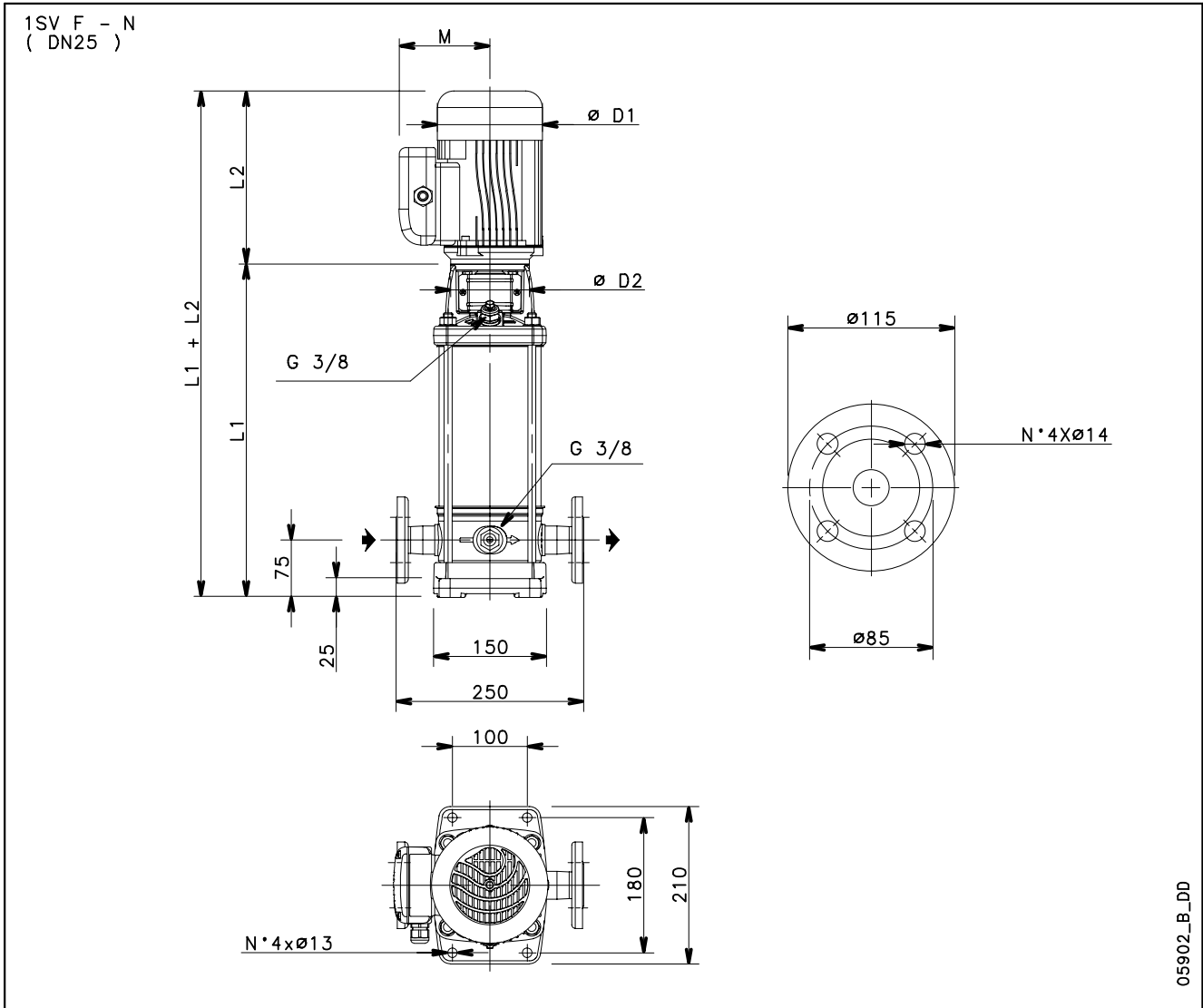

05902_B_DD

PUMP TYPE	MOTOR		DIMENSIONS (mm)								WEIGHT kg	
	kW	SIZE	L1	L2		M		D1		D2	PUMP	ELECTRIC
1SV17..L./D	1,1	80	568	263	263	137	129	155	155	120	14,7	26,6
1SV19..L./D	1,1	80	608	263	263	137	129	155	155	120	15,5	27,4
1SV22..L./D	1,1	80	668	263	263	137	129	155	155	120	16,7	28,6
1SV25..L./D	1,5	90	738	263	263	137	129	155	155	140	18,7	31,7
1SV27..L./D	1,5	90	778	263	263	137	129	155	155	140	19,5	32,5
1SV30..L./D	1,5	90	838	263	263	137	129	155	155	140	20,7	33,7
1SV32..L.	2,2	90	878	298	298	151	134	174	174	140	21,5	37,8
1SV34..L.	2,2	90	918	298	298	151	134	174	174	140	22,3	38,6
1SV37..L.	2,2	90	978	298	298	151	134	174	174	140	23,5	39,8

1SV..L SERIES - LOW NPSH - 17 TO 37 STAGES
OPERATING CHARACTERISTICS AT 50 Hz, 2-POLE

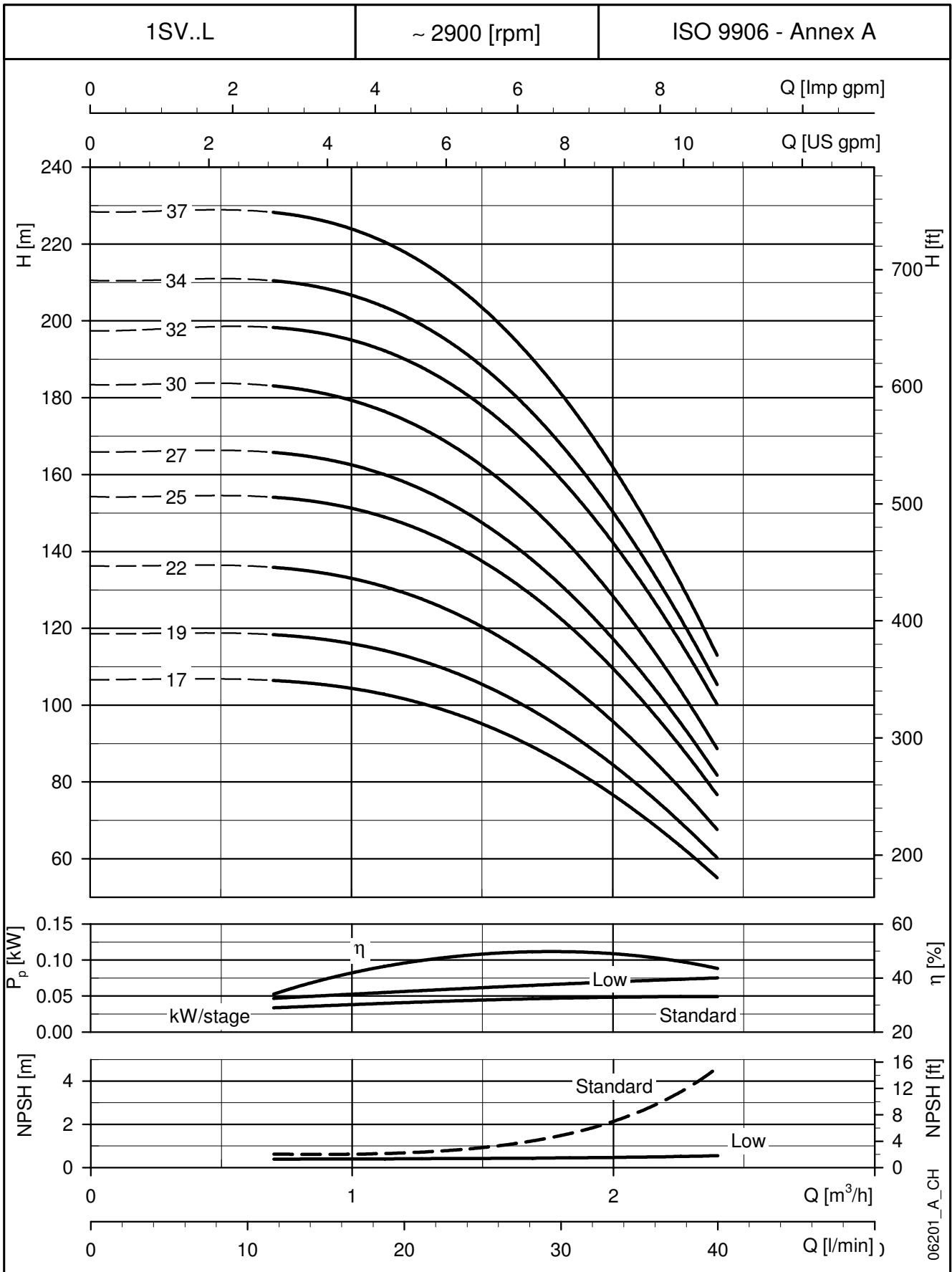

LOW NPSH

50Hz

06201_A_CH

These performances are valid for liquids with density $\rho = 1.0 \text{ Kg/dm}^3$ and kinematic viscosity $\nu = 1 \text{ mm}^2/\text{sec}$.

**3SV..L SERIES - LOW NPSH
DIMENSIONS AND WEIGHTS AT 50 Hz, 2-POLE**

**LOW
NPSH
50Hz**

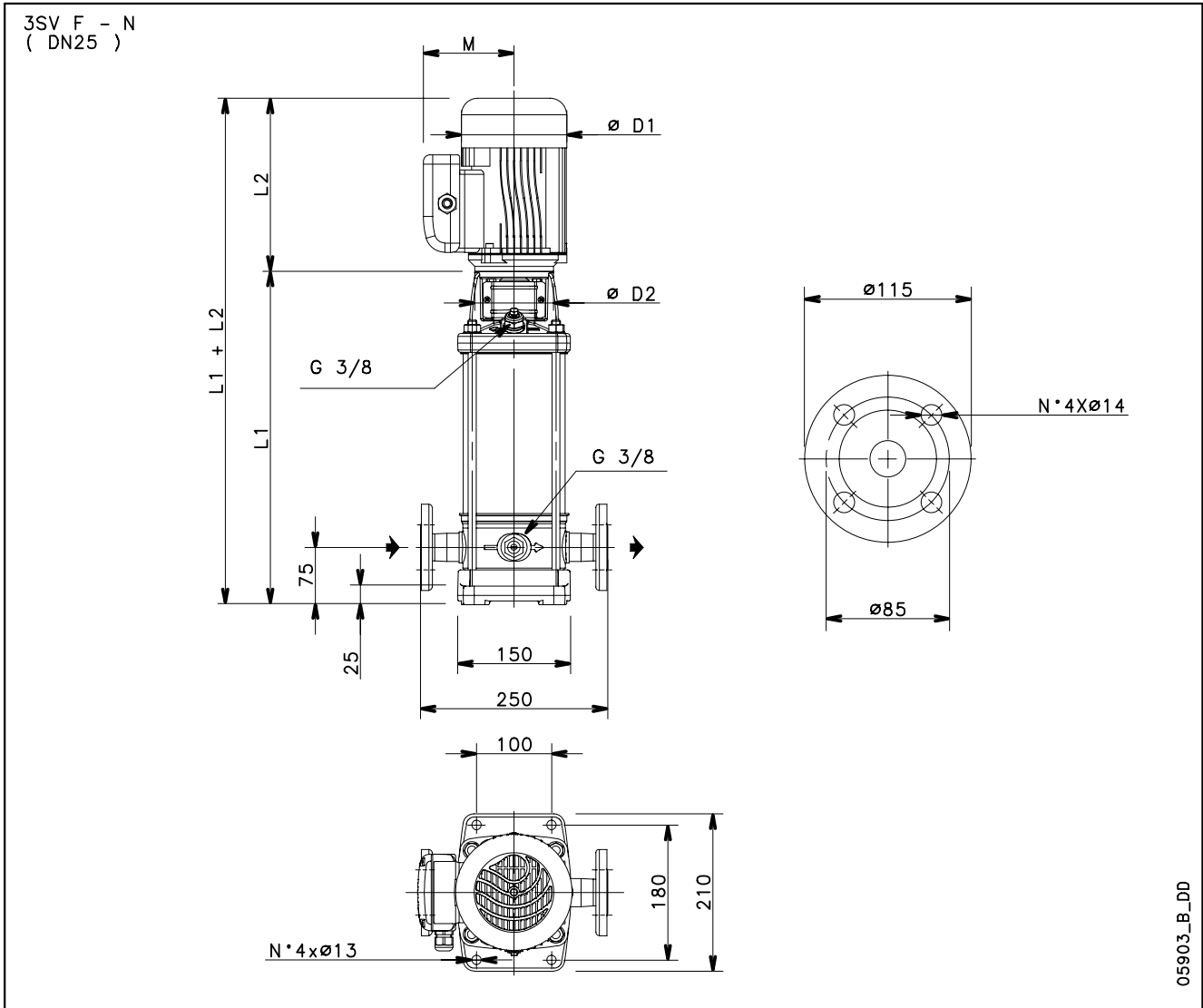

05903_B_DD

PUMP TYPE	MOTOR		DIMENSIONS (mm)								WEIGHT kg	
	kW	SIZE	L1	L2		M		D1		D2	PUMP	ELECTRIC
3SV03..L..	0,37	71	278	209	209	111	111	120	120	105	8,4	13,2
3SV04..L..	0,37	71	298	209	209	111	111	120	120	105	8,8	13,6
3SV05..L..	0,55	71	318	231	231	121	121	140	140	105	9,2	14
3SV06..L..	0,55	71	338	231	231	121	121	140	140	105	9,7	16,4
3SV07..L./D	0,75	80	368	226	263	121	129	140	155	120	10,9	20,5
3SV08..L./D	0,75	80	388	226	263	121	129	140	155	120	11,3	20,9
3SV09..L./D	1,1	80	408	263	263	137	129	155	155	120	11,7	23,1
3SV10..L./D	1,1	80	428	263	263	137	129	155	155	120	12,1	23,5
3SV11..L./D	1,1	80	448	263	263	137	129	155	155	120	12,5	23,9
3SV12..L./D	1,1	80	468	263	263	137	129	155	155	120	13,3	24,7
3SV13..L./D	1,5	90	498	263	263	137	129	155	155	140	14	27
3SV14..L./D	1,5	90	518	263	263	137	129	155	155	140	14,4	27,5
3SV16..L./D	1,5	90	558	263	263	137	129	155	155	140	15,2	28,2
3SV19..L..	2,2	90	618	298	298	151	134	174	174	140	16,4	34,4
3SV21..L..	2,2	90	658	298	298	151	134	174	174	140	17,2	35,2
3SV23..L..	2,2	90	698	298	298	151	134	174	174	140	18	36
3SV25..L..	2,2	90	738	298	298	151	134	174	174	140	18,9	36,8
3SV27..L..	3	100	788	-	298	-	134	-	174	160	20,7	42,6
3SV29..L..	3	100	828	-	298	-	134	-	174	160	21,5	43,4
3SV31..L..	3	100	868	-	298	-	134	-	174	160	22,3	44,2
3SV33..L..	3	100	908	-	298	-	134	-	174	160	23,1	45

**3SV..L SERIES - LOW NPSH
OPERATING CHARACTERISTICS AT 50 Hz, 2-POLE**

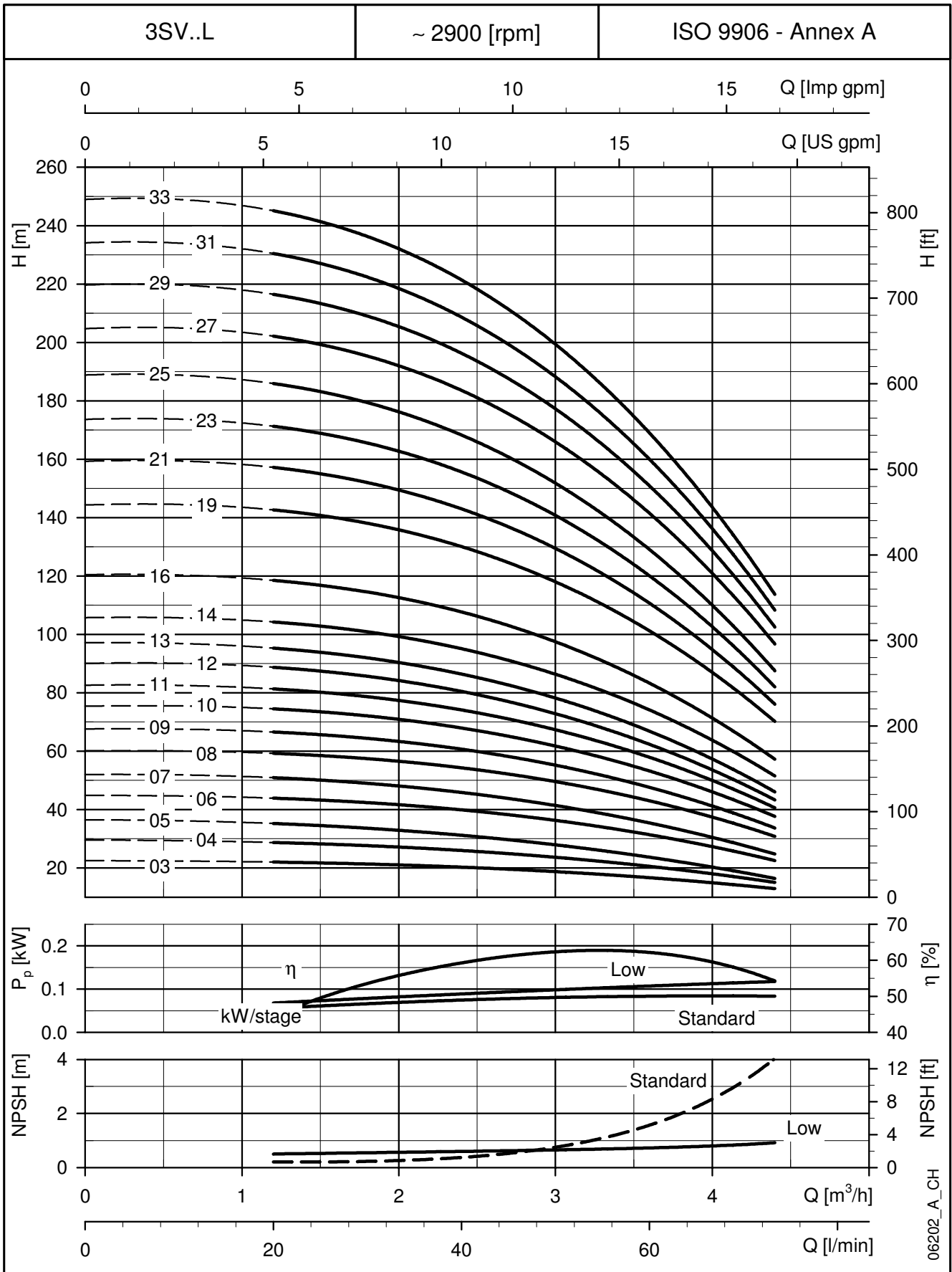

LOW NPSH

50Hz

These performances are valid for liquids with density $\rho = 1.0 \text{ Kg/dm}^3$ and kinematic viscosity $\nu = 1 \text{ mm}^2/\text{sec}$.

5SV..L SERIES - LOW NPSH DIMENSIONS AND WEIGHTS AT 50 Hz, 2-POLE

LOW
NPSH
50Hz

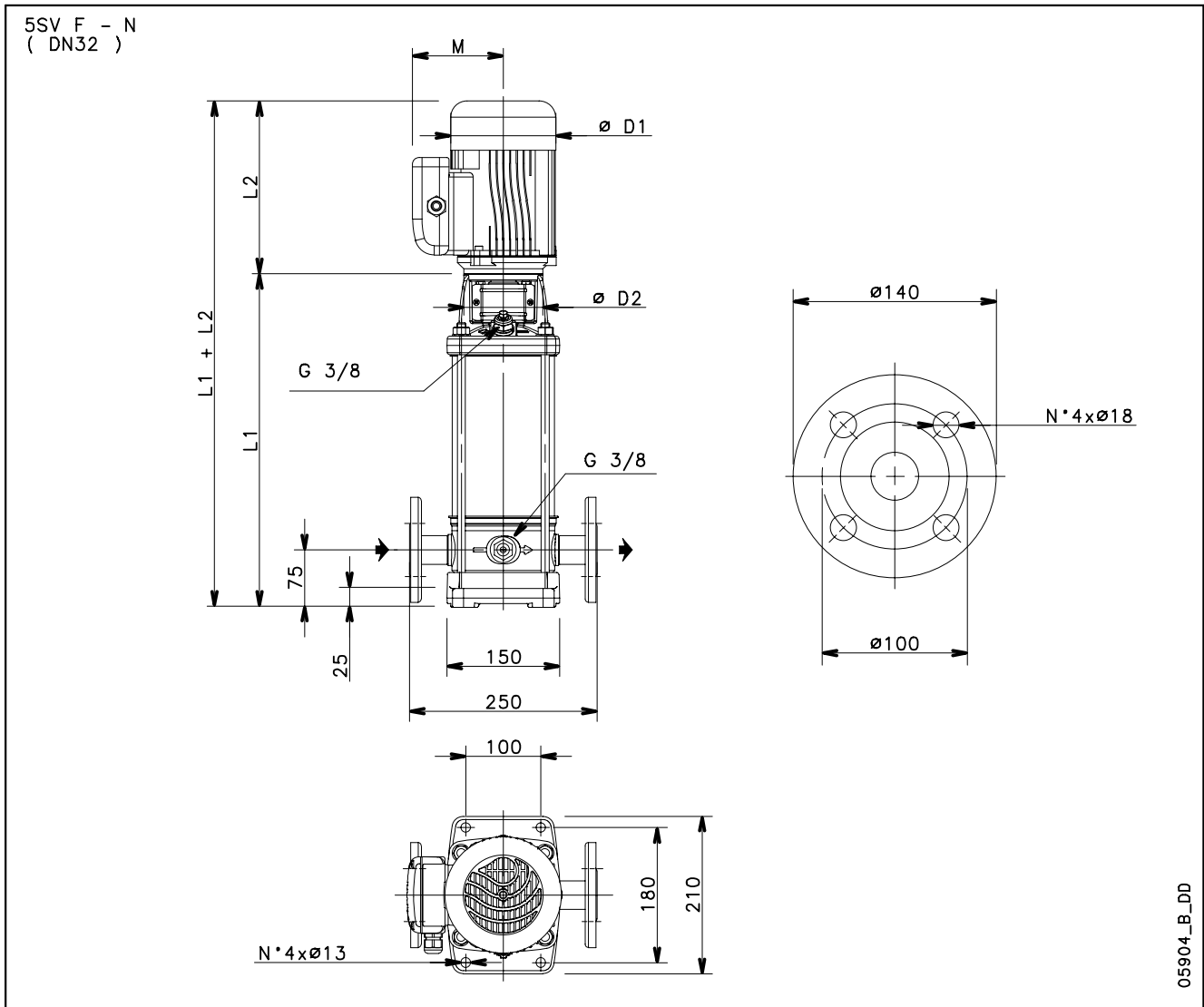

05904_B_DD

PUMP TYPE	MOTOR		DIMENSIONS (mm)								WEIGHT kg	
	kW	SIZE	L1	L2		M		D1		D2	PUMP	ELECTRIC
5SV03..L./D	0,75	80	303	226	263	121	129	140	155	120	9,6	19,2
5SV04..L./D	0,75	80	328	226	263	121	129	140	155	120	10	19,6
5SV05..L./D	1,1	80	353	263	263	137	129	155	155	120	10,5	21,9
5SV06..L./D	1,1	80	378	263	263	137	129	155	155	120	11	22,4
5SV07..L./D	1,5	90	413	263	263	137	129	155	155	140	11,8	25
5SV08..L./D	1,5	90	438	263	263	137	129	155	155	140	12,3	25,6
5SV09..L./D	1,5	90	463	263	263	137	129	155	155	140	12,7	26
5SV10..L./D	1,5	90	488	263	263	137	129	155	155	140	13,2	26,5
5SV11..L.	2,2	90	513	298	298	151	134	174	174	140	13,7	31,9
5SV12..L.	2,2	90	538	298	298	151	134	174	174	140	14,1	32,3
5SV13..L.	2,2	90	563	298	298	151	134	174	174	140	14,6	32,8
5SV14..L.	2,2	90	588	298	298	151	134	174	174	140	15	33,2
5SV15..L.	2,2	90	613	298	298	151	134	174	174	140	15,5	33,7
5SV16..L.	3	100	648	-	298	-	134	-	174	160	17	38
5SV18..L.	3	100	698	-	298	-	134	-	174	160	18	39
5SV21..L.	3	100	773	-	298	-	134	-	174	160	19,4	40,4
5SV23..L.	4	112	823	-	319	-	154	-	197	160	20,4	47
5SV25..L.	4	112	873	-	319	-	154	-	197	160	21,3	48
5SV28..L.	4	112	948	-	319	-	154	-	197	160	23	49,4
5SV30..L.	5,5	132	1018	-	375	-	168	-	214	300	28,1	65,7
5SV33..L.	5,5	132	1093	-	375	-	168	-	214	300	29,5	67,1

**5SV..L SERIES - LOW NPSH
OPERATING CHARACTERISTICS AT 50 Hz, 2-POLE**

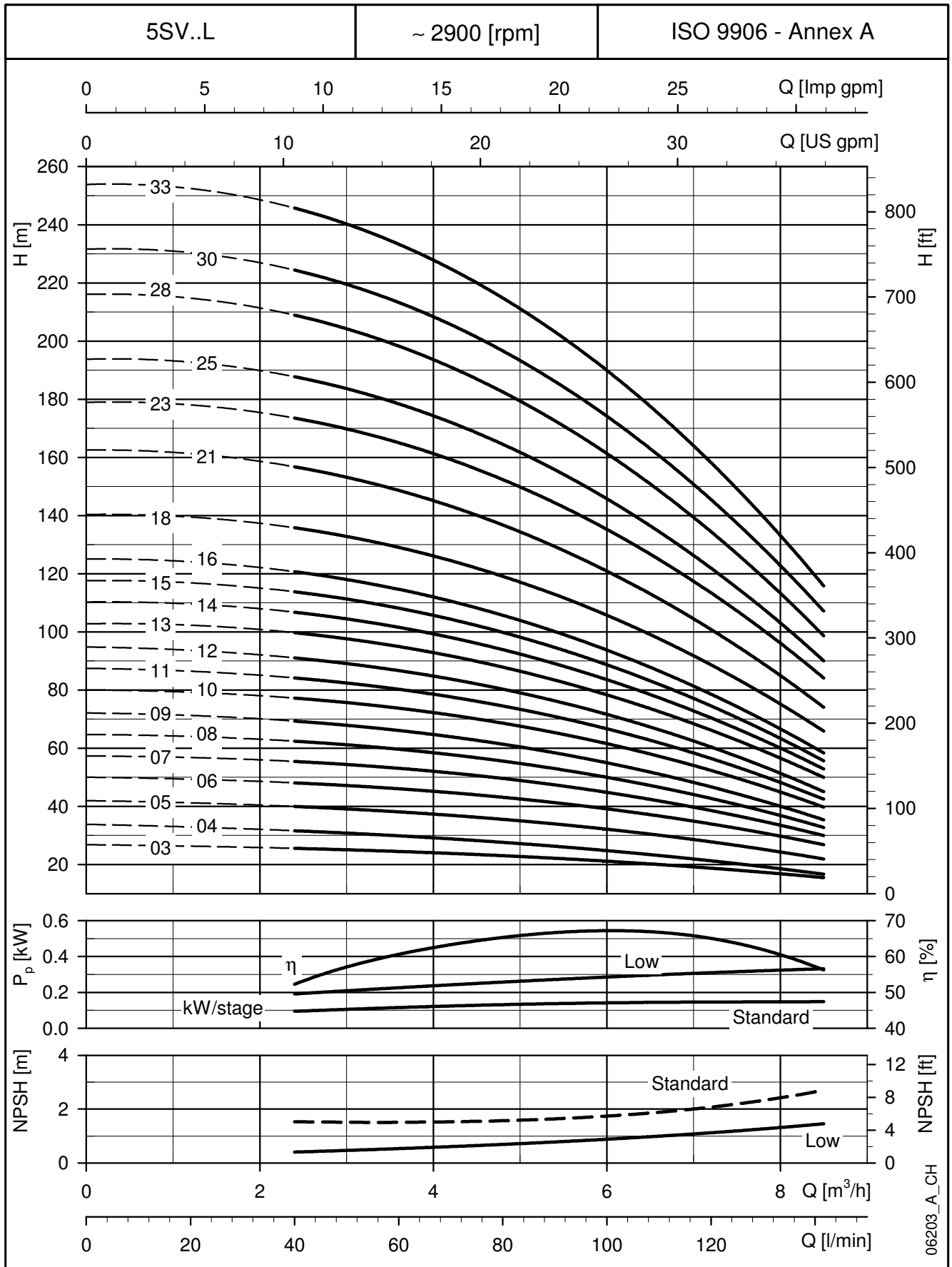

LOW NPSH 50Hz

These performances are valid for liquids with density $\rho = 1.0 \text{ Kg/dm}^3$ and kinematic viscosity $\nu = 1 \text{ mm}^2/\text{sec}$.

10SV..L SERIES - LOW NPSH DIMENSIONS AND WEIGHTS AT 50 Hz, 2-POLE

LOW NPSH 50Hz

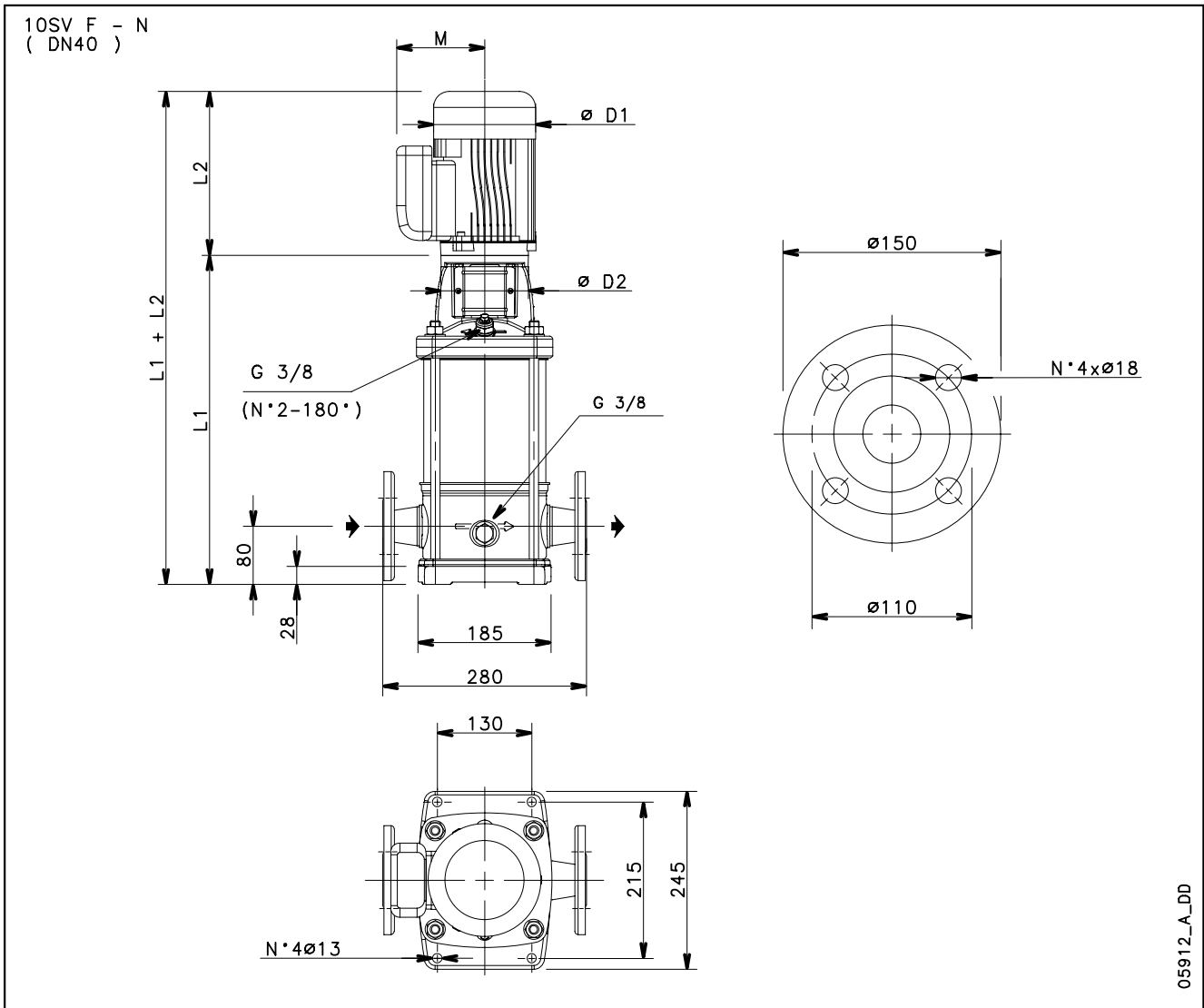

PUMP TYPE	MOTOR		DIMENSIONS (mm)								WEIGHT kg	
	KW	SIZE	L1	L2		M		D1		D2	PUMP	ELECTRIC
10SV03..L./D	1,5	90	399	263	263	137	129	155	155	140	16,6	29,6
10SV04..L..	2,2	90	431	298	298	151	134	174	174	140	17,6	35,8
10SV05..L..	2,2	90	463	298	298	151	134	174	174	140	18,5	36,7
10SV06..L..	3	100	505	-	298	-	134	-	174	160	20,6	41,6
10SV07..L..	3	100	537	-	298	-	134	-	174	160	21,5	42,5
10SV08..L..	3	100	569	-	298	-	134	-	174	160	22,4	43,4
10SV09..L..	4	112	601	-	319	-	154	-	197	160	23,3	49,7
10SV10..L..	4	112	633	-	319	-	154	-	197	160	24,3	50,7
10SV11..L..	5,5	132	732	-	375	-	168	-	214	300	31,2	68,8
10SV13..L..	5,5	132	796	-	375	-	168	-	214	300	33,1	71
10SV15..L..	5,5	132	860	-	375	-	168	-	214	300	35	73
10SV17..L..	7,5	132	924	-	367	-	191	-	256	300	36,9	93
10SV18..L..	7,5	132	956	-	367	-	191	-	256	300	37,8	94
10SV20..L..	7,5	132	1020	-	367	-	191	-	256	300	39,6	96
10SV21..L..	11	160	1082	-	428	-	191	-	256	350	42,2	113

**10SV..L SERIES - LOW NPSH
OPERATING CHARACTERISTICS AT 50 Hz, 2-POLE**

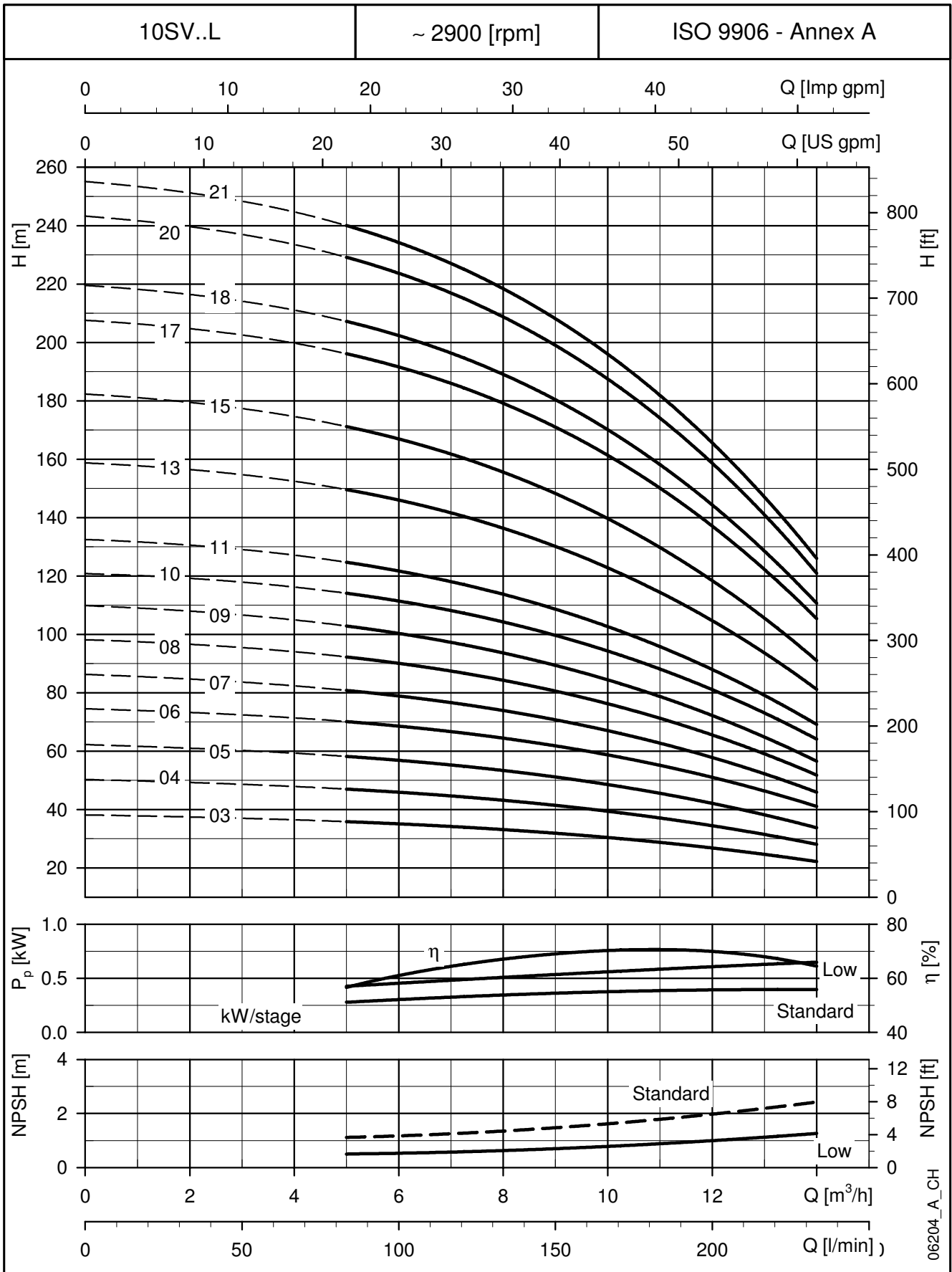

LOW NPSH 50Hz

These performances are valid for liquids with density $\rho = 1.0 \text{ Kg/dm}^3$ and kinematic viscosity $\nu = 1 \text{ mm}^2/\text{sec}$.

15SV..L SERIES - LOW NPSH DIMENSIONS AND WEIGHTS AT 50 Hz, 2-POLE

LOW NPSH 50Hz

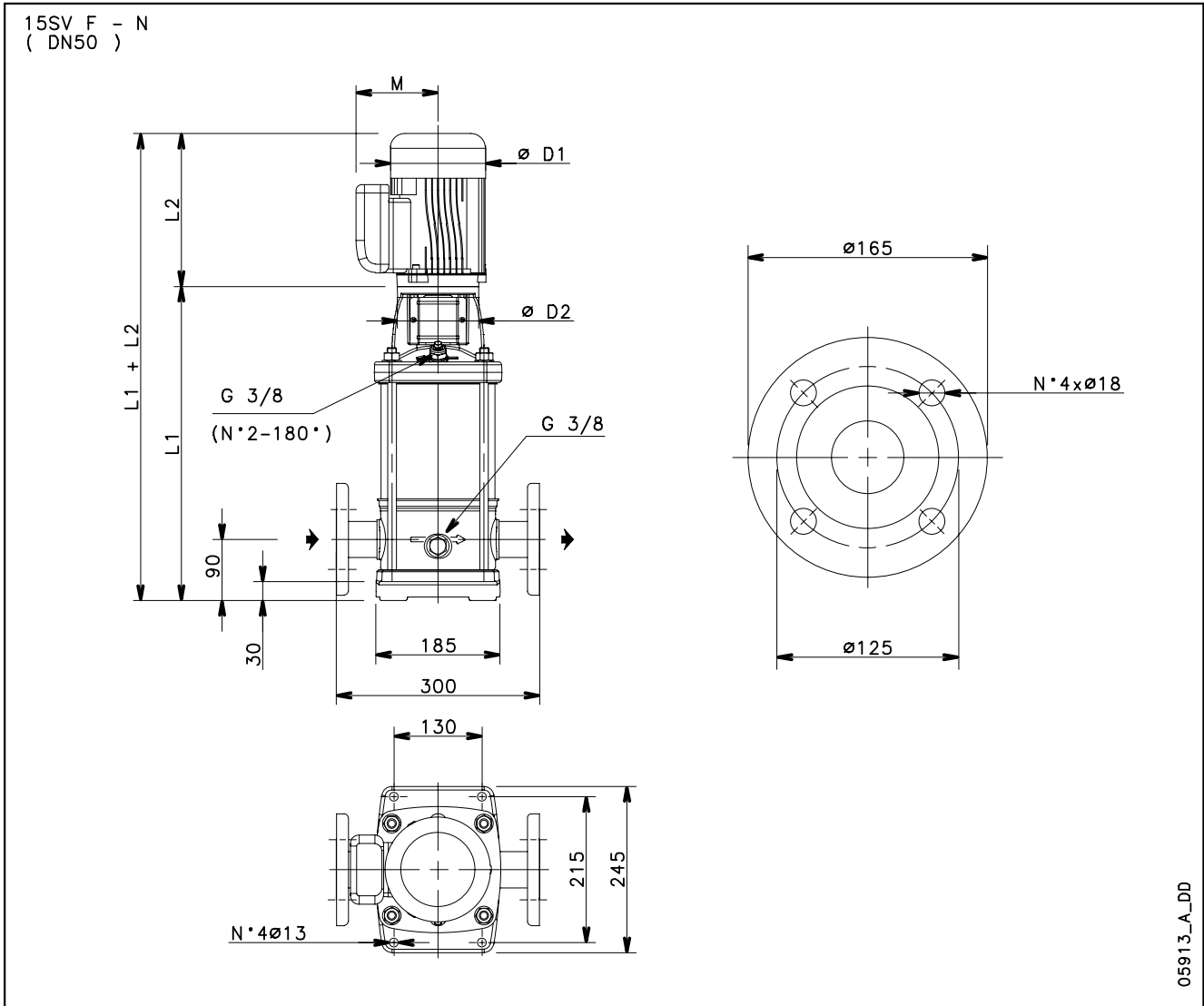

PUMP TYPE	MOTOR		DIMENSIONS (mm)					WEIGHT kg	
	kW	SIZE	L1	L2	M	D1	D2	PUMP	ELECTRIC
15SV02..L..	3	100	419	298	134	174	160	17,6	36,6
15SV03..L..	4	112	467	319	154	197	160	19	45,4
15SV04..L..	4	112	515	319	154	197	160	20,3	46,8
15SV05..L..	5,5	132	630	375	168	214	300	27,6	65,2
15SV06..L..	5,5	132	678	375	168	214	300	28,9	67
15SV07..L..	7,5	132	726	367	191	256	300	30,2	86
15SV08..L..	7,5	132	774	367	191	256	300	31,5	88
15SV09..L..	11	160	852	428	191	256	350	35,7	106
15SV10..L..	11	160	900	428	191	256	350	37	108
15SV11..L..	11	160	948	428	191	256	350	38,3	109
15SV13..L..	11	160	1044	428	191	256	350	41	112
15SV15..L..	15	160	1140	494	240	313	350	43,7	146
15SV17..L..	15	160	1236	494	240	313	350	46,7	149

**15SV..L SERIES - LOW NPSH
OPERATING CHARACTERISTICS AT 50 Hz, 2-POLE**

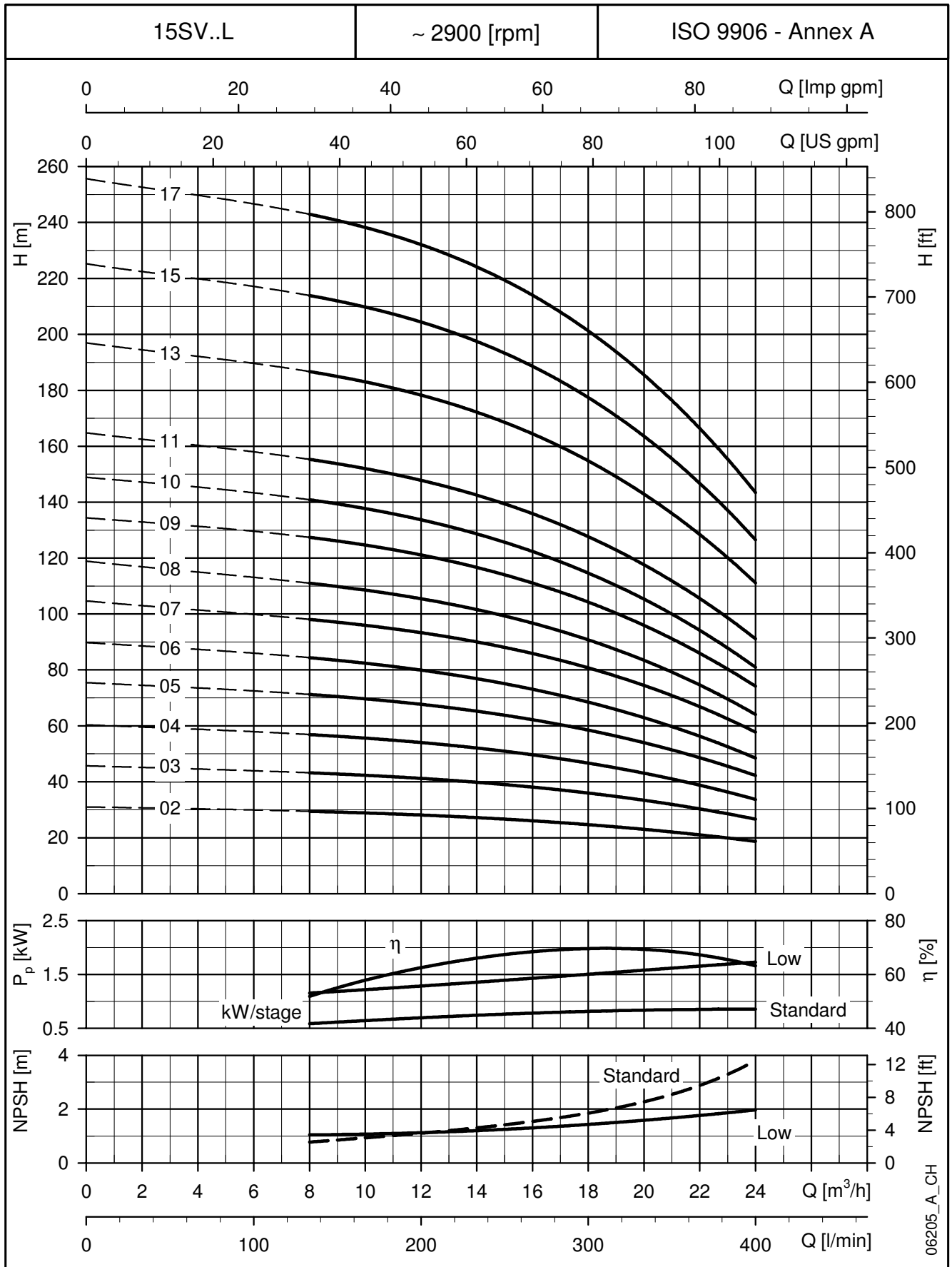

LOW NPSH 50Hz

These performances are valid for liquids with density $\rho = 1.0 \text{ Kg/dm}^3$ and kinematic viscosity $\nu = 1 \text{ mm}^2/\text{sec}$.

22SV..L SERIES - LOW NPSH DIMENSIONS AND WEIGHTS AT 50 Hz, 2-POLE

LOW
NPSH
50Hz

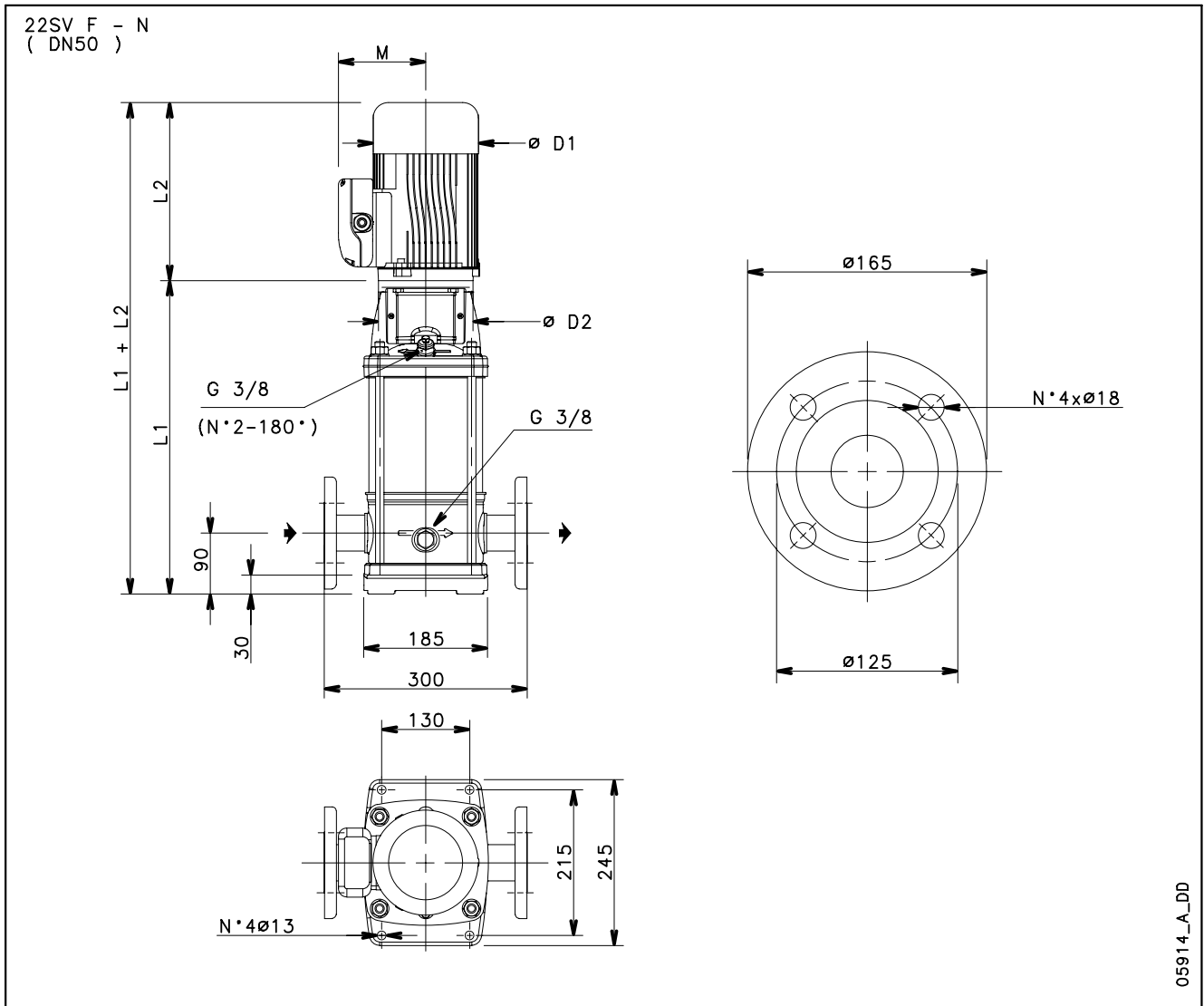

PUMP TYPE	MOTOR		DIMENSIONS (mm)					WEIGHT kg	
	kw	SIZE	L1	L2	M	D1	D2	PUMP	ELECTRIC PUMP
22SV02..L..	3	100	419	298	134	174	160	18	39
22SV03..L..	4	112	467	319	154	197	160	19,4	46
22SV04..L..	5,5	132	582	375	168	214	300	25,4	63
22SV05..L..	5,5	132	630	375	168	214	300	26,7	65
22SV06..L..	7,5	132	678	367	191	256	300	28	84
22SV07..L..	11	160	756	428	191	256	350	31,8	102
22SV08..L..	11	160	804	428	191	256	350	33,1	104
22SV09..L..	11	160	852	428	191	256	350	34,4	105
22SV10..L..	11	160	900	428	191	256	350	35,8	107
22SV12..L..	15	160	996	494	240	313	350	38,4	141
22SV14..L..	15	160	1092	494	240	313	350	41,1	144
22SV17..L..	18,5	160	1236	494	240	313	350	45,1	156

**22SV..L SERIES - LOW NPSH
OPERATING CHARACTERISTICS AT 50 Hz, 2-POLE**

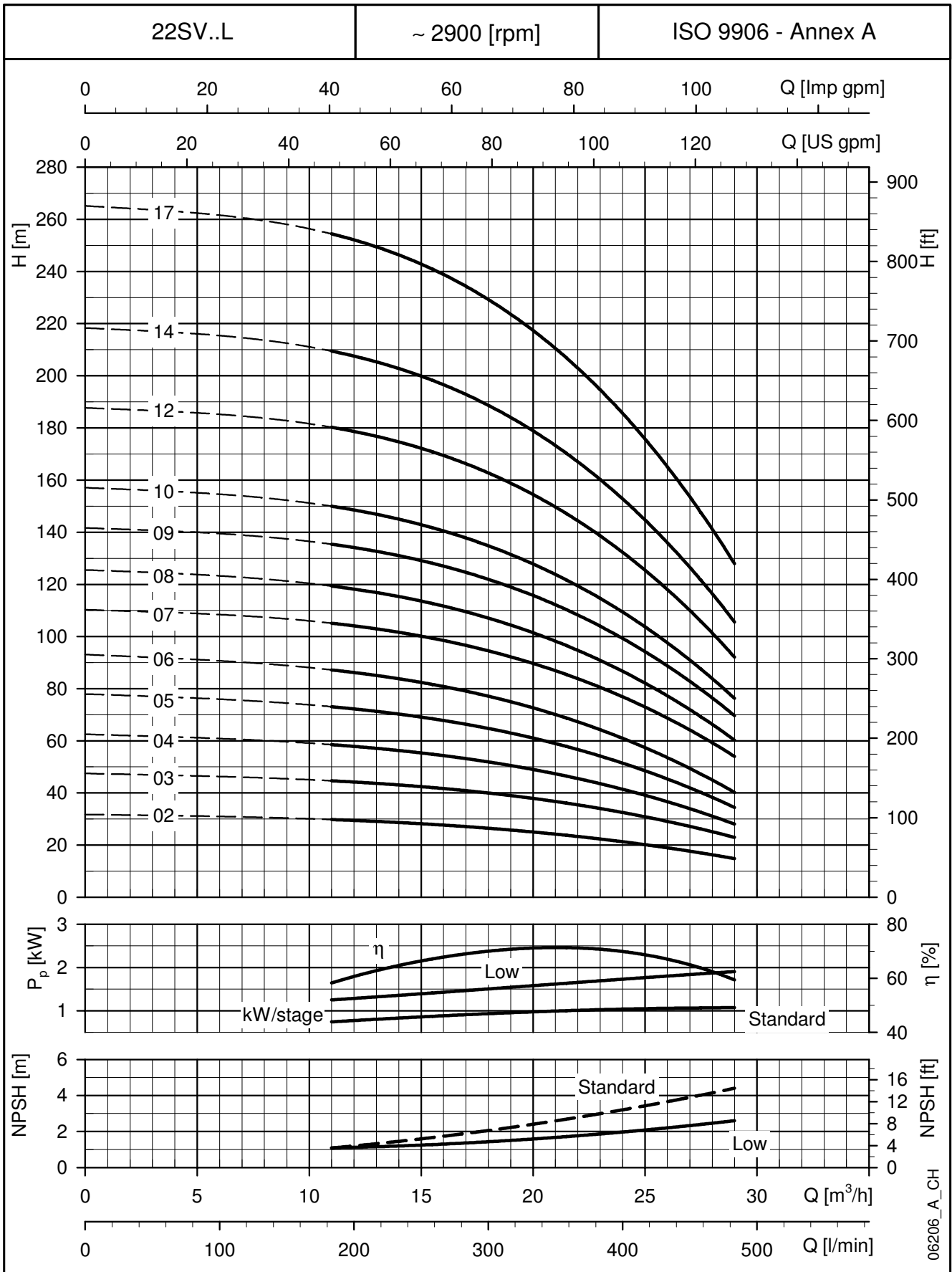

LOW NPSH

50Hz

06206_A_CH

These performances are valid for liquids with density $\rho = 1.0 \text{ Kg/dm}^3$ and kinematic viscosity $\nu = 1 \text{ mm}^2/\text{sec}$.

33SV..L SERIES - LOW NPSH DIMENSIONS AND WEIGHTS AT 50 Hz, 2-POLE

LOW NPSH

50Hz

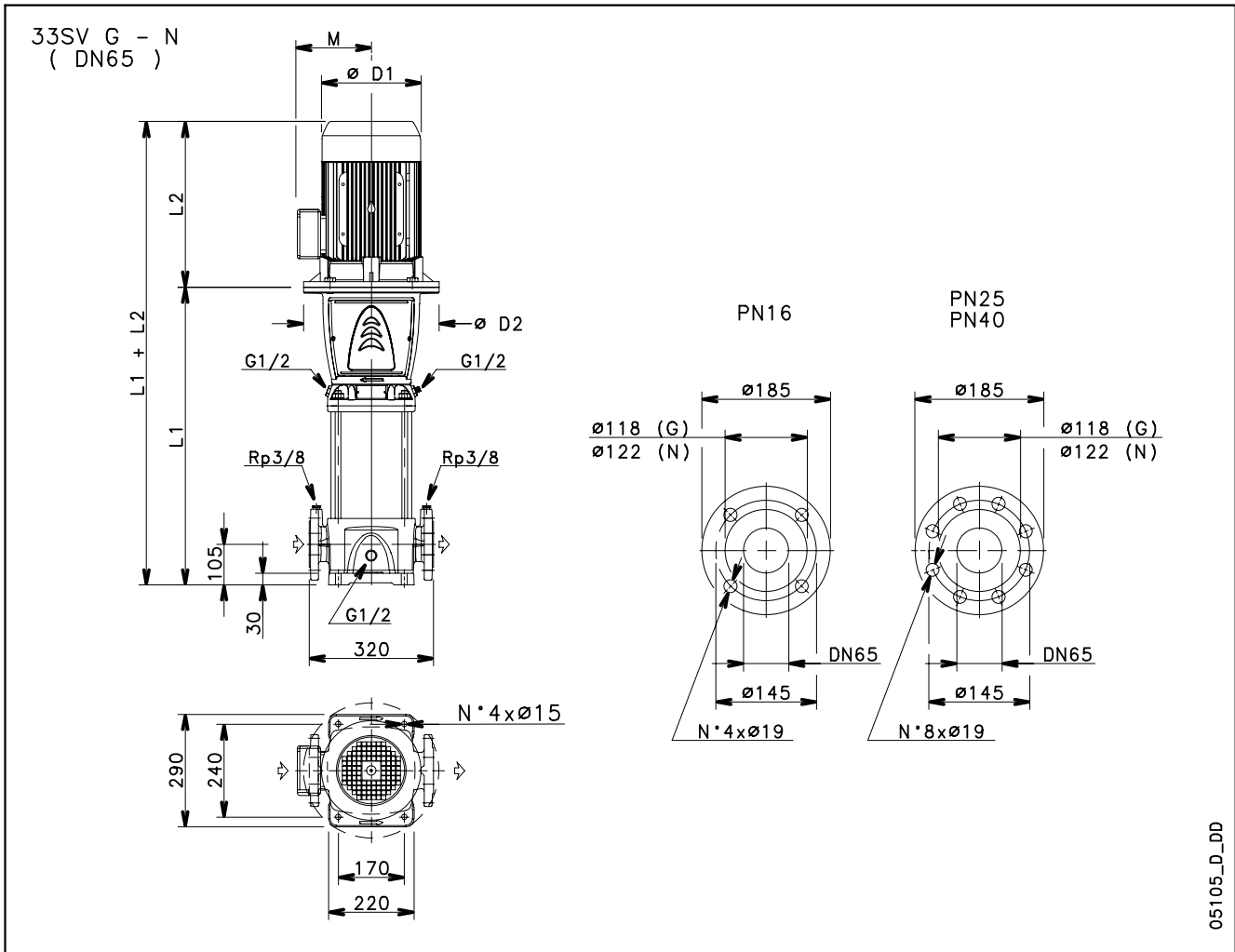

PUMP TYPE	MOTOR		DIMENSIONS (mm)						WEIGHT kg	
	kW	SIZE	L1	L2	D1	D2	M	PN	PUMP	ELECTRIC PUMP
33SV2/1A..L..	5,5	132	584	375	214	300	168	16	61	99
33SV2..L..	5,5	132	584	375	214	300	168	16	61	99
33SV3/2A..L..	7,5	132	659	367	256	300	191	16	65	121
33SV3/1A..L..	7,5	132	659	367	256	300	191	16	65	121
33SV3..L..	7,5	132	659	367	256	300	191	16	65	121
33SV4/2A..L..	11	160	769	428	256	350	191	16	73	144
33SV4/1A..L..	11	160	769	428	256	350	191	16	73	144
33SV4..L..	11	160	769	428	256	350	191	16	73	144
33SV5/2A..L..	11	160	844	428	256	350	191	16	77	148
33SV5/1A..L..	15	160	844	494	313	350	240	16	77	179
33SV5..L..	15	160	844	494	313	350	240	16	77	179
33SV6/2A..L..	15	160	919	494	313	350	240	16	81	183
33SV6/1A..L..	15	160	919	494	313	350	240	25	81	183
33SV6..L..	15	160	919	494	313	350	240	25	81	183
33SV7/2A..L..	18,5	160	994	494	313	350	240	25	84	195
33SV7/1A..L..	18,5	160	994	494	313	350	240	25	84	195
33SV7..L..	18,5	160	994	494	313	350	240	25	84	195

PUMP TYPE	MOTOR		DIMENSIONS (mm)						WEIGHT kg	
	kW	SIZE	L1	L2	D1	D2	M	PN	PUMP	ELECTRIC PUMP
33SV8/2A..L..	18,5	160	1069	494	313	350	240	25	88	199
33SV8/1A..L..	22	180	1069	494	313	350	240	25	89	211
33SV8..L..	22	180	1069	494	313	350	240	25	89	211
33SV9/2A..L..	22	180	1144	494	313	350	240	25	93	215
33SV9/1A..L..	22	180	1144	494	313	350	240	25	93	215
33SV9..L..	22	180	1144	494	313	350	240	25	93	215
33SV10/2A..L..	30	200	1219	657	402	400	317	25	104	319
33SV10/1A..L..	30	200	1219	657	402	400	317	25	104	319
33SV10..L..	30	200	1219	657	402	400	317	25	104	319
33SV11/2A..L..	30	200	1294	657	402	400	317	40	118	333
33SV11/1A..L..	30	200	1294	657	402	400	317	40	118	333
33SV11..L..	30	200	1294	657	402	400	317	40	118	333
33SV12/2A..L..	30	200	1369	657	402	400	317	40	122	337
33SV12/1A..L..	30	200	1369	657	402	400	317	40	122	337
33SV12..L..	30	200	1369	657	402	400	317	40	122	337
33SV13/2A..L..	30	200	1444	657	402	400	317	40	127	342
33SV13/1A..L..	37	200	1444	657	402	400	317	40	127	357

33SV..L SERIES - LOW NPSH OPERATING CHARACTERISTICS AT 50 Hz, 2-POLE

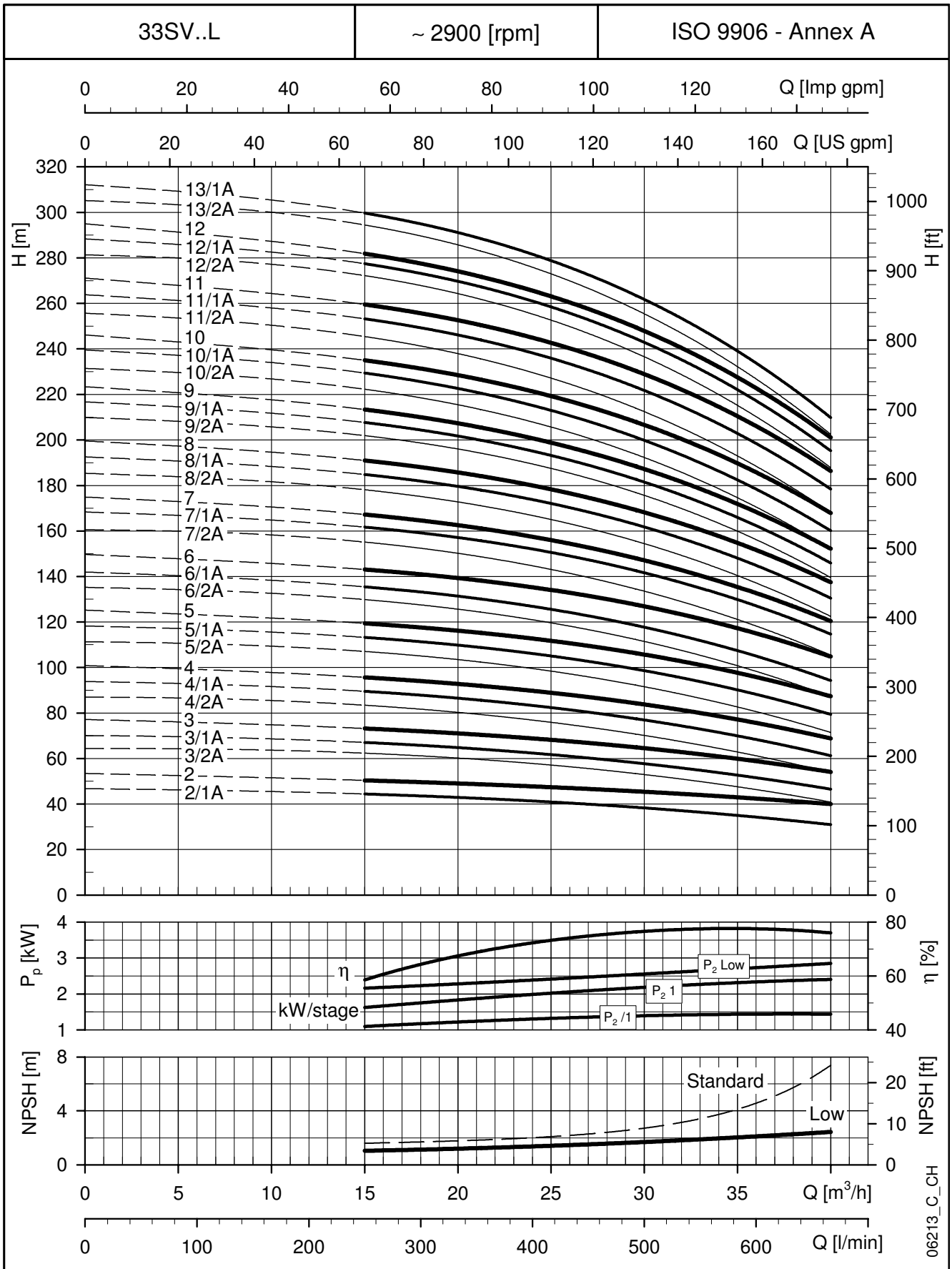

These performances are valid for liquids with density $\rho = 1.0 \text{ Kg/dm}^3$ and kinematic viscosity $\nu = 1 \text{ mm}^2/\text{sec}$.

46SV..L SERIES - LOW NPSH DIMENSIONS AND WEIGHTS AT 50 Hz, 2-POLE

LOW NPSH 50Hz

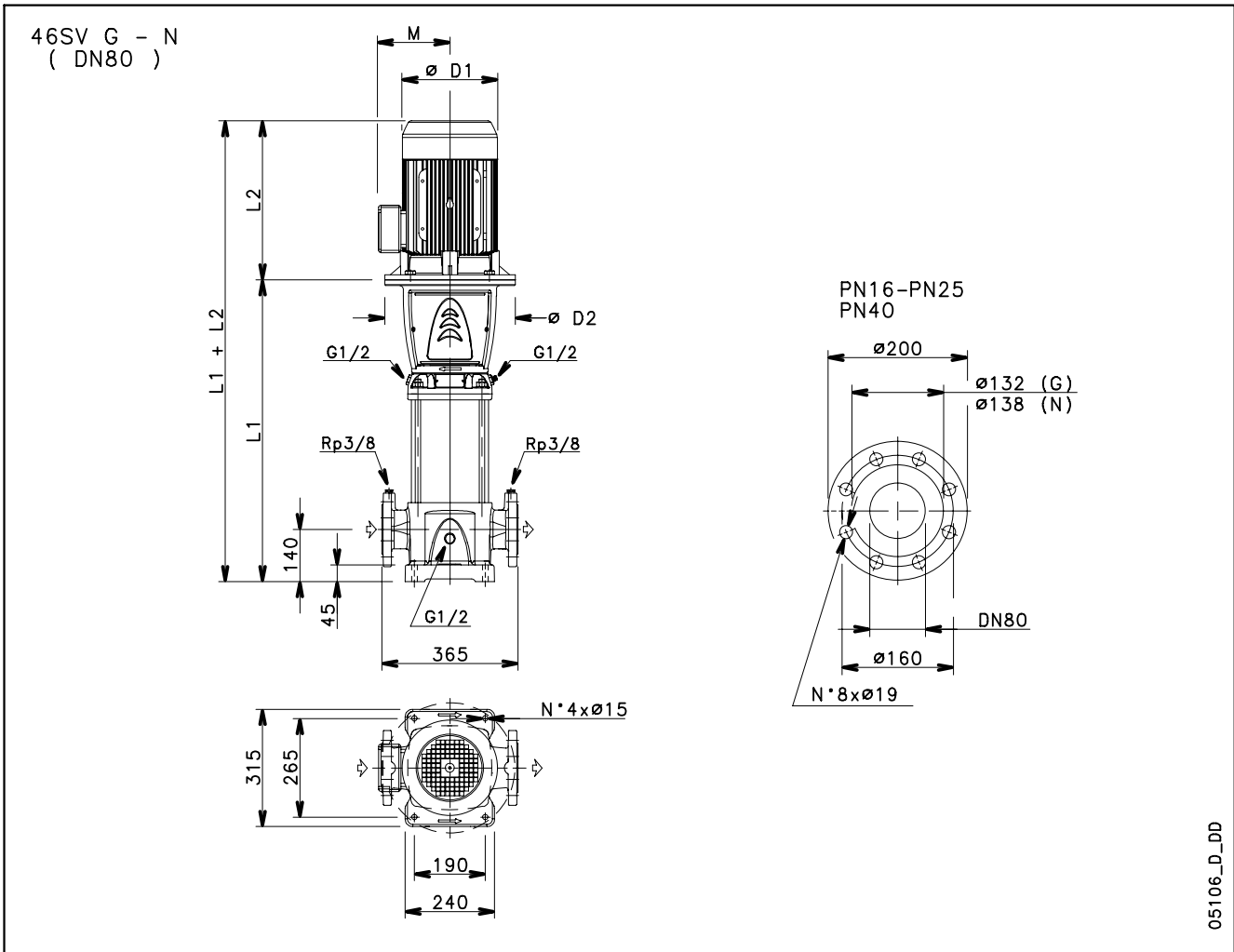

05106_D_DD

PUMP TYPE	MOTOR		DIMENSIONS (mm)							WEIGHT kg		PUMP TYPE	MOTOR		DIMENSIONS (mm)							WEIGHT kg		
	kW	SIZE	L1	L2	D1	D2	M	PN	PUMP	ELECTRIC PUMP	kW		SIZE	L1	L2	D1	D2	M	PN	PUMP	ELECTRIC PUMP			
46SV2/1A..L..	7,5	132	624	367	256	300	191	16	66	122	46SV10..L..	37	200	1259	657	402	400	317	40	114	344			
46SV2..L..	11	160	659	428	256	350	191	16	70	141	46SV11/2A..L..	45	225	1334	746	455	450	384	40	126	482			
46SV3/2A..L..	11	160	734	428	256	350	191	16	74	145	46SV11..L..	45	225	1334	746	455	450	384	40	126	482			
46SV3..L..	15	160	734	494	313	350	240	16	74	176	46SV12/2A..L..	45	225	1409	746	455	450	384	40	131	487			
46SV4/2A..L..	15	160	809	494	313	350	240	16	78	180	46SV12..L..	45	225	1409	746	455	450	384	40	131	487			
46SV4..L..	15	160	809	494	313	350	240	16	78	180														
46SV5/2A..L..	18,5	160	884	494	313	350	240	16	82	193														
46SV5..L..	18,5	160	884	494	313	350	240	16	82	193														
46SV6/2A..L..	22	180	959	494	313	350	240	25	87	209														
46SV6..L..	22	180	959	494	313	350	240	25	87	209														
46SV7/2A..L..	30	200	1034	657	402	400	317	25	97	312														
46SV7..L..	30	200	1034	657	402	400	317	25	97	312														
46SV8/2A..L..	30	200	1109	657	402	400	317	25	101	316														
46SV8..L..	30	200	1109	657	402	400	317	25	101	316														
46SV9/2A..L..	37	200	1184	657	402	400	317	25	105	335														
46SV9..L..	37	200	1184	657	402	400	317	25	105	335														
46SV10/2A..L..	37	200	1259	657	402	400	317	40	114	344														

**46SV..L SERIES - LOW NPSH
OPERATING CHARACTERISTICS AT 50 Hz, 2-POLE**

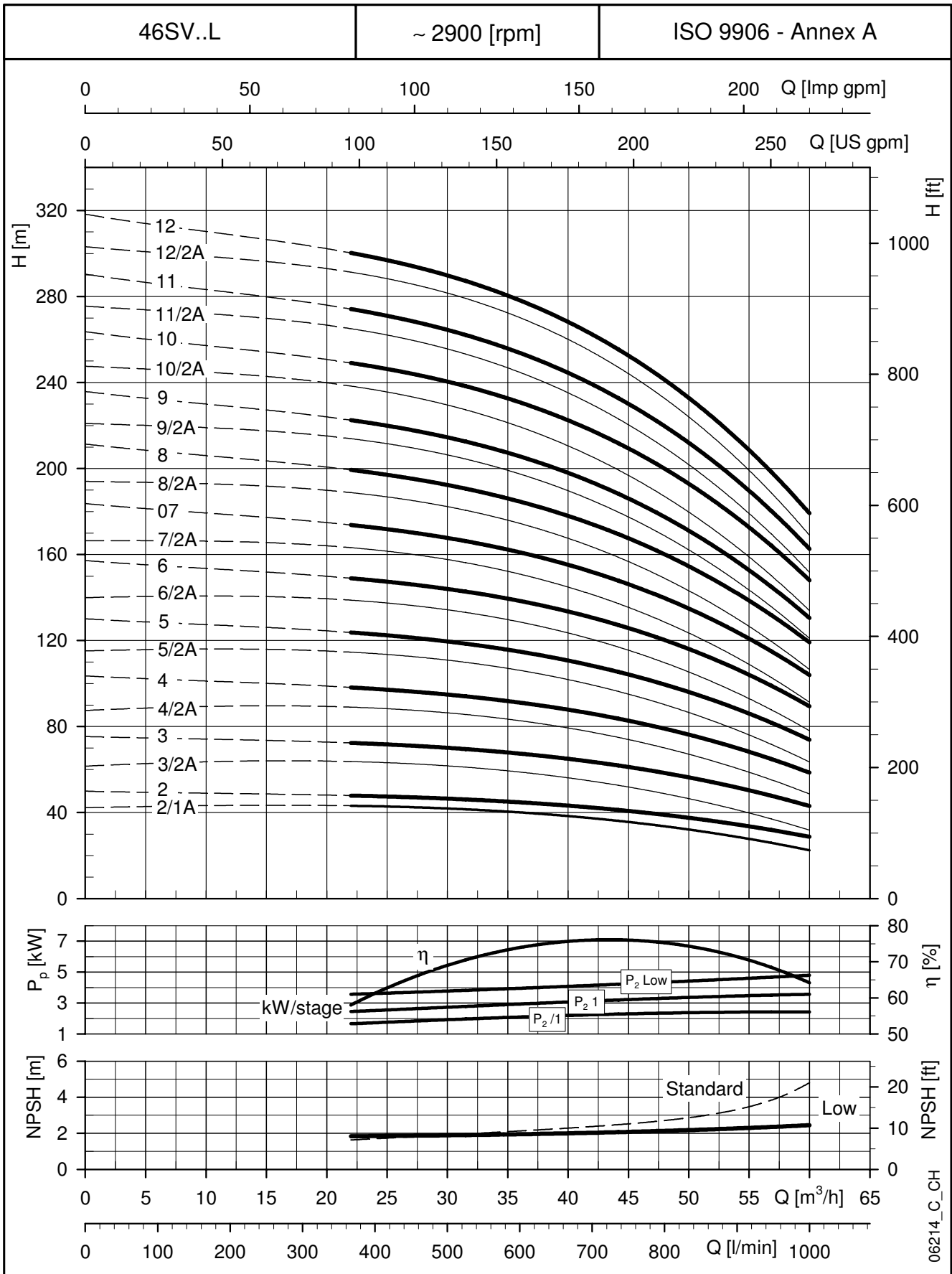

LOW NPSH

50Hz

06214_C_CH

These performances are valid for liquids with density $\rho = 1.0 \text{ Kg/dm}^3$ and kinematic viscosity $\nu = 1 \text{ mm}^2/\text{sec}$.

**66SV..L SERIES - LOW NPSH
DIMENSIONS AND WEIGHTS AT 50 Hz, 2-POLE**

**LOW
NPSH
50Hz**

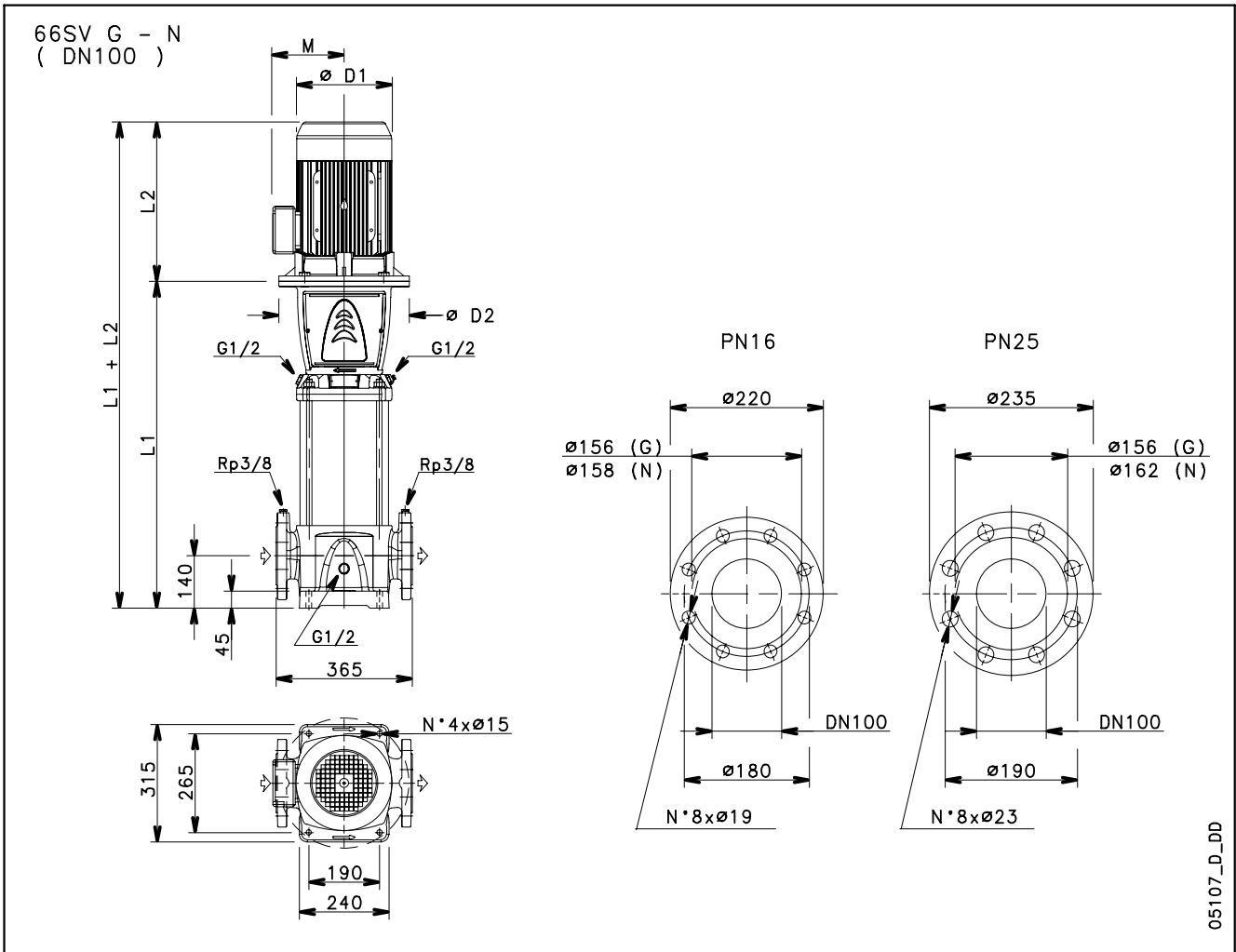

05107_D_DD

PUMP TYPE	MOTOR		DIMENSIONS (mm)							WEIGHT kg	
	kW	SIZE	L1	L2	D1	D2	M	PN	PUMP	ELECTRIC PUMP	
66SV2/1A..L..	11	160	699	428	256	350	191	16	81	152	
66SV2..L..	15	160	699	494	313	350	240	16	81	183	
66SV3/2A..L..	15	160	789	494	313	350	240	16	86	188	
66SV3/1A..L..	18,5	160	789	494	313	350	240	16	86	197	
66SV3..L..	18,5	160	789	494	313	350	240	16	86	197	
66SV4/2A..L..	22	180	879	494	313	350	240	16	93	215	
66SV4/1A..L..	22	180	879	494	313	350	240	16	93	215	
66SV4..L..	30	200	879	657	402	400	317	16	100	315	
66SV5/2A..L..	30	200	969	657	402	400	317	16	105	320	
66SV5/1A..L..	30	200	969	657	402	400	317	16	105	320	
66SV5..L..	30	200	969	657	402	400	317	16	105	320	
66SV6/2A..L..	30	200	1059	657	402	400	317	25	113	328	
66SV6/1A..L..	37	200	1059	657	402	400	317	25	113	343	
66SV6..L..	37	200	1059	657	402	400	317	25	113	343	
66SV7/2A..L..	37	200	1149	657	402	400	317	25	118	348	
66SV7/1A..L..	37	200	1149	657	402	400	317	25	118	348	
66SV7..L..	45	225	1149	746	455	450	384	25	122	478	
66SV8/2A..L..	45	225	1239	746	455	450	384	25	127	483	
66SV8/1A..L..	45	225	1239	746	455	450	384	25	127	483	
66SV8..L..	45	225	1239	746	455	450	384	25	127	483	

**66SV..L SERIES - LOW NPSH
OPERATING CHARACTERISTICS AT 50 Hz, 2-POLE**

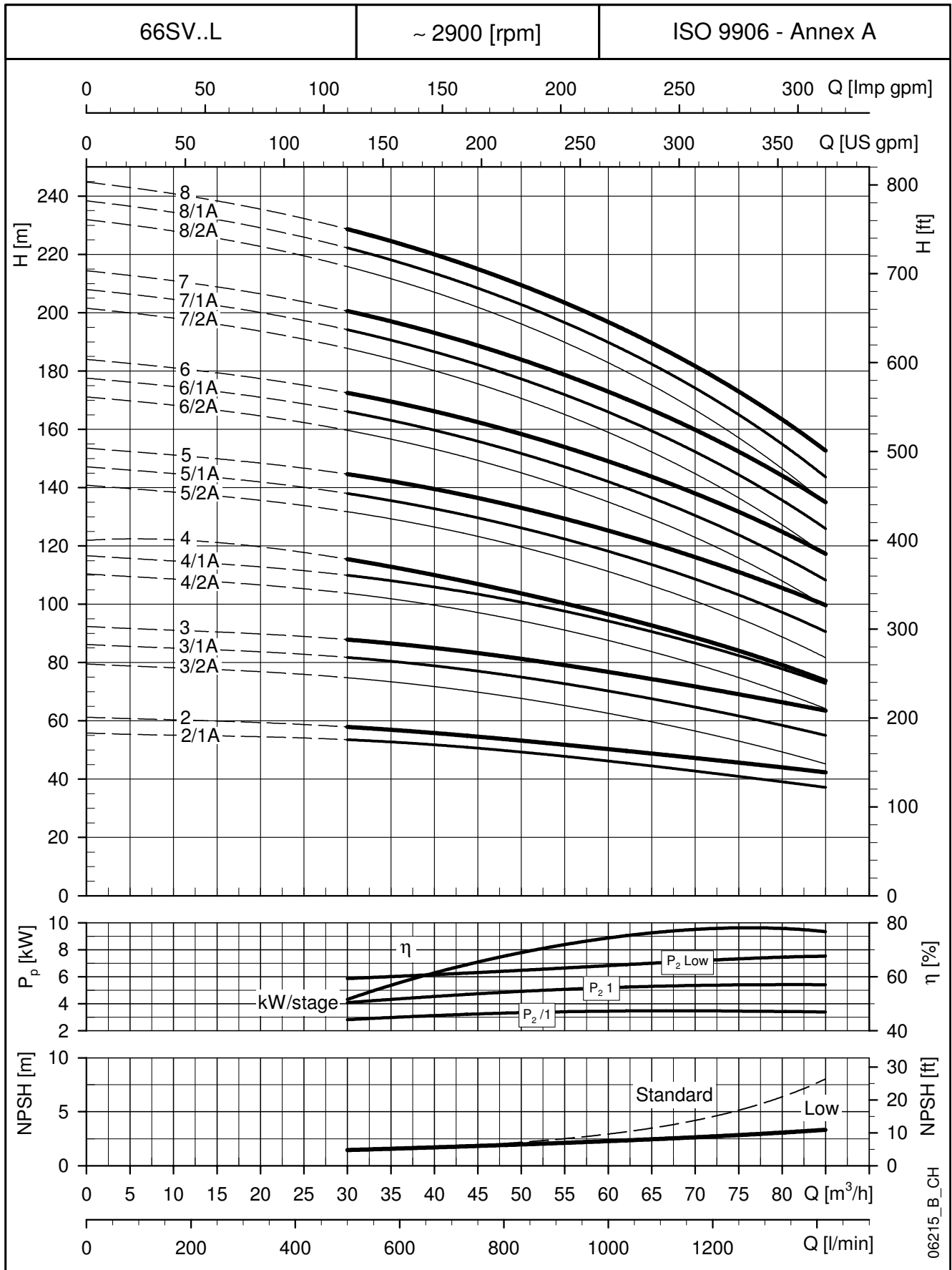

LOW NPSH 50Hz

These performances are valid for liquids with density $\rho = 1.0 \text{ Kg/dm}^3$ and kinematic viscosity $\nu = 1 \text{ mm}^2/\text{sec}$.

1SV..L SERIES - LOW NPSH DIMENSIONS AND WEIGHTS AT 60 Hz, 2-POLE

LOW
NPSH
60Hz

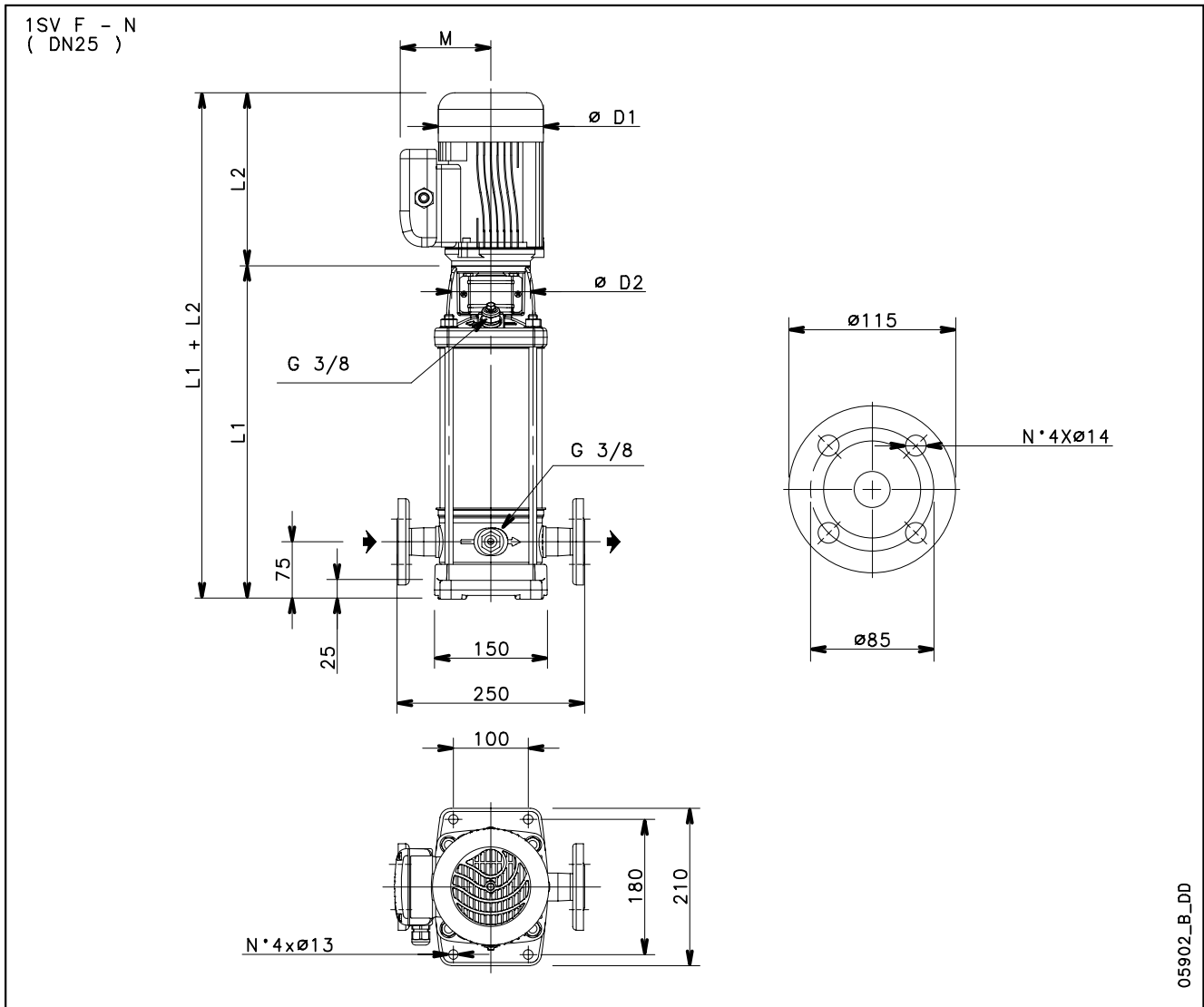

05902_B_DD

PUMP TYPE	MOTOR		DIMENSIONS (mm)								WEIGHT kg	
	kW	SIZE	L1	L2		M		D1		D2	PUMP	ELECTRIC
1SV03..L..	0,37	71	278	209	209	111	111	120	120	105	8,6	13,4
1SV04..L..	0,37	71	298	209	209	111	111	120	120	105	9	13,8
1SV05..L..	0,55	71	318	231	231	121	121	140	140	105	9,4	16,1
1SV06..L..	0,55	71	338	231	231	121	121	140	140	105	9,8	16,5
1SV07..L./D	0,75	80	368	226	263	121	129	140	155	120	10,6	20,2
1SV08..L./D	0,75	80	388	226	263	121	129	140	155	120	11	20,6
1SV09..L./D	1,1	80	408	263	263	137	129	155	155	120	11,4	21
1SV10..L./D	1,1	80	428	263	263	137	129	155	155	120	11,8	23,2
1SV11..L./D	1,1	80	448	263	263	137	129	155	155	120	12,2	23,6
1SV12..L./D	1,1	80	468	263	263	137	129	155	155	120	12,6	24
1SV13..L./D	1,1	80	488	263	263	137	129	155	155	120	13	24,4
1SV15..L./D	1,5	90	538	263	263	137	129	155	155	140	14,1	27
1SV17..L./D	1,5	90	578	263	263	137	129	155	155	140	14,9	28
1SV18..L..	2,2	90	598	298	298	151	134	174	174	140	15,3	33,5
1SV20..L..	2,2	90	638	298	298	151	134	174	174	140	16,1	34,3
1SV22..L..	2,2	90	678	298	298	151	134	174	174	140	16,9	35
1SV24..L..	2,2	90	718	298	298	151	134	174	174	140	17,7	35,8
1SV26..L..	2,2	90	758	298	298	151	134	174	174	140	18,5	36,6
1SV28..L..	3	100	808	-	298	-	134	-	174	140	19,7	40,7

**1SV..L SERIES - LOW NPSH
OPERATING CHARACTERISTICS AT 60 Hz, 2-POLE**

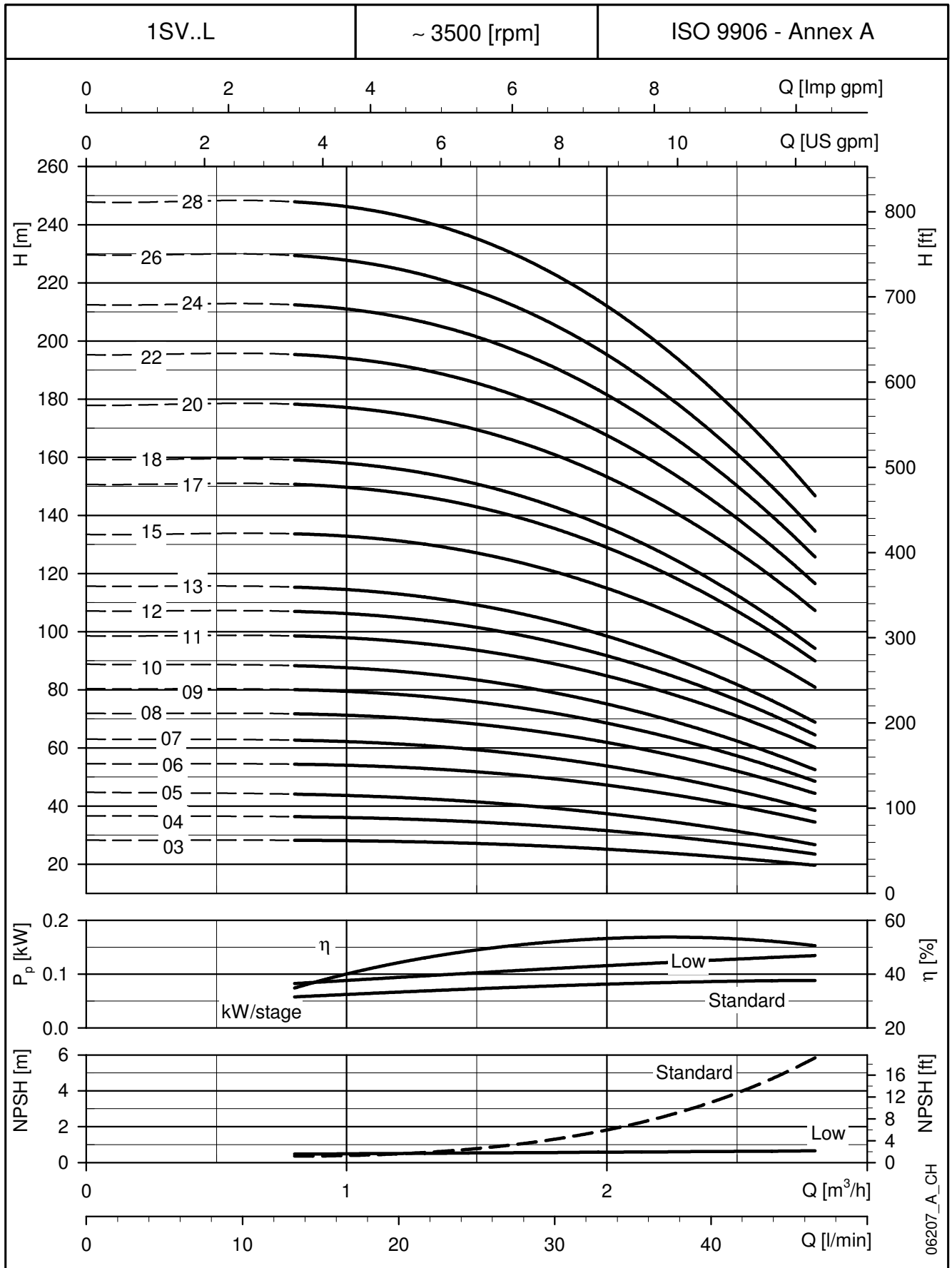

These performances are valid for liquids with density $\rho = 1.0 \text{ Kg/dm}^3$ and kinematic viscosity $\nu = 1 \text{ mm}^2/\text{sec}$.

3SV..L SERIES - LOW NPSH DIMENSIONS AND WEIGHTS AT 60 Hz, 2-POLE

LOW NPSH 60Hz

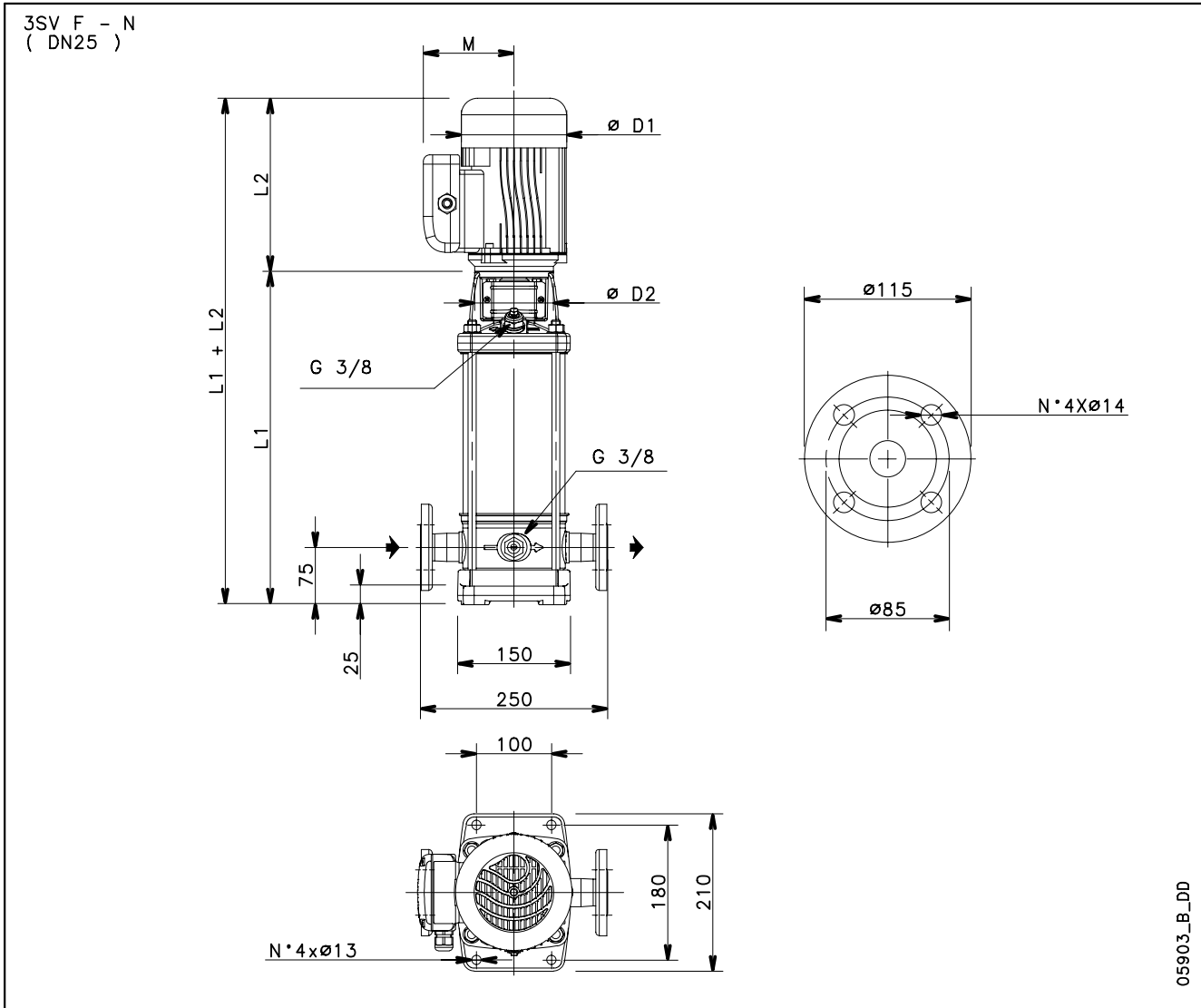

PUMP TYPE	MOTOR		DIMENSIONS (mm)								WEIGHT kg	
	kW	SIZE	L1	L2		M		D1		D2	PUMP	ELECTRIC
				1 ~	3 ~	1 ~	3 ~	1 ~	3 ~			
3SV03..L..	0,55	71	278	231	231	121	121	140	140	105	8,5	15,2
3SV04..L./D	0,75	80	308	226	263	121	129	140	155	120	9,3	18,9
3SV05..L./D	1,1	80	328	263	263	137	129	155	155	120	9,7	21,1
3SV06..L./D	1,1	80	348	263	263	137	129	155	155	120	10,1	21,5
3SV07..L./D	1,1	80	368	263	263	137	129	155	155	140	10,5	21,9
3SV08..L./D	1,5	90	398	263	263	137	129	155	155	140	11,2	24,5
3SV09..L./D	1,5	90	418	263	263	137	129	155	155	140	11,6	25
3SV10..L..	2,2	90	438	298	298	151	134	174	174	140	12	30,2
3SV11..L..	2,2	90	458	298	298	151	134	174	174	140	12,4	30,6
3SV12..L..	2,2	90	478	298	298	151	134	174	174	140	12,8	30,9
3SV13..L..	2,2	90	498	298	298	151	134	174	174	140	13,2	31,3
3SV14..L..	2,2	90	518	298	298	151	134	174	174	140	13,6	31,7
3SV15..L..	3	100	548	-	298	-	134	-	174	160	14,4	35,4
3SV17..L..	3	100	588	-	298	-	134	-	174	160	15,2	36,2
3SV19..L..	3	100	628	-	298	-	134	-	174	160	16	37
3SV21..L..	4	112	668	-	319	-	154	-	197	160	16,8	43,2
3SV23..L..	4	112	708	-	319	-	154	-	197	160	17,6	44

**3SV..L SERIES - LOW NPSH
OPERATING CHARACTERISTICS AT 60 Hz, 2-POLE**

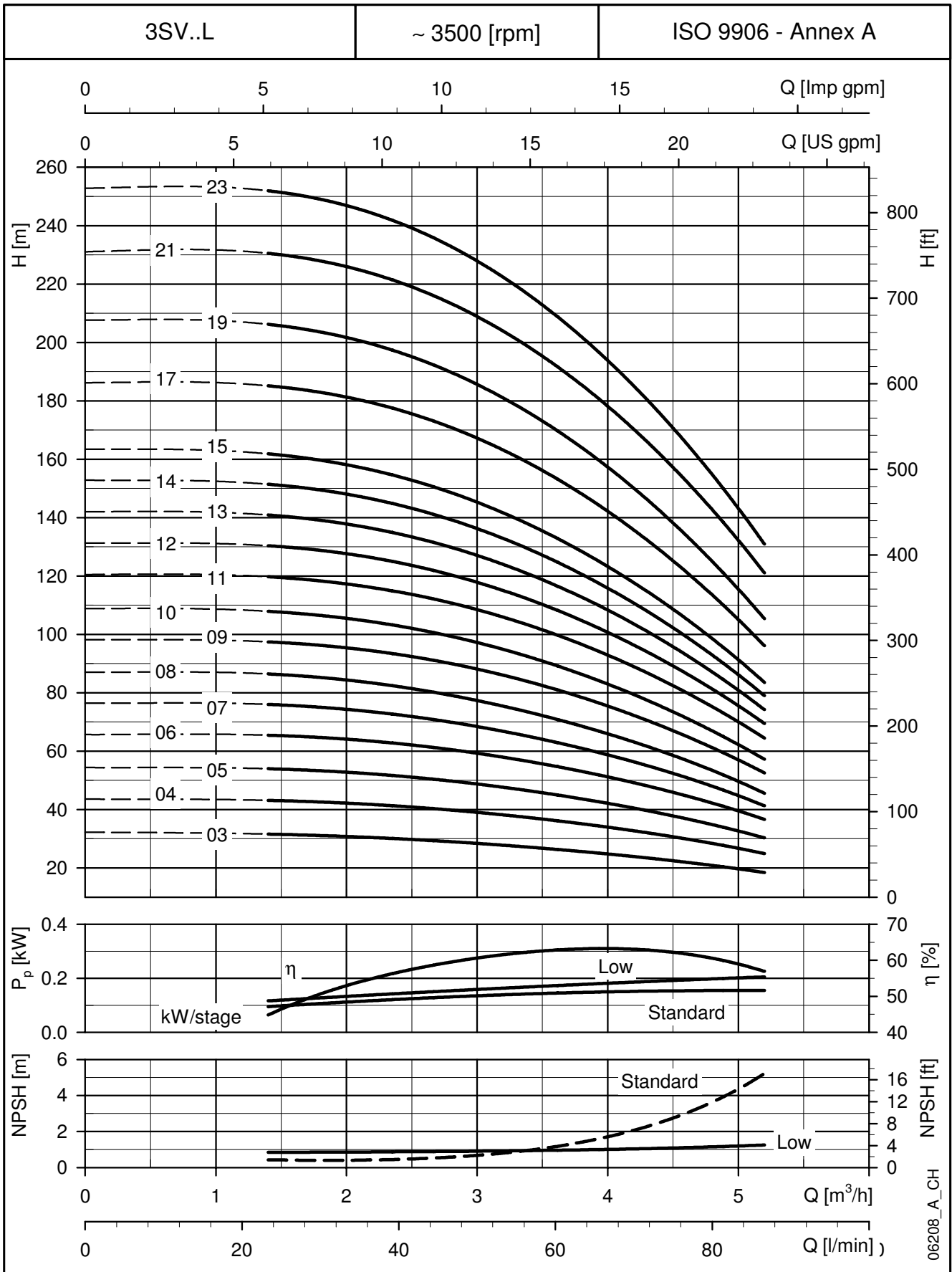

LOW NPSH 60Hz

These performances are valid for liquids with density $\rho = 1.0 \text{ Kg/dm}^3$ and kinematic viscosity $\nu = 1 \text{ mm}^2/\text{sec}$.

5SV..L SERIES - LOW NPSH DIMENSIONS AND WEIGHTS AT 60 Hz, 2-POLE

LOW NPSH 60Hz

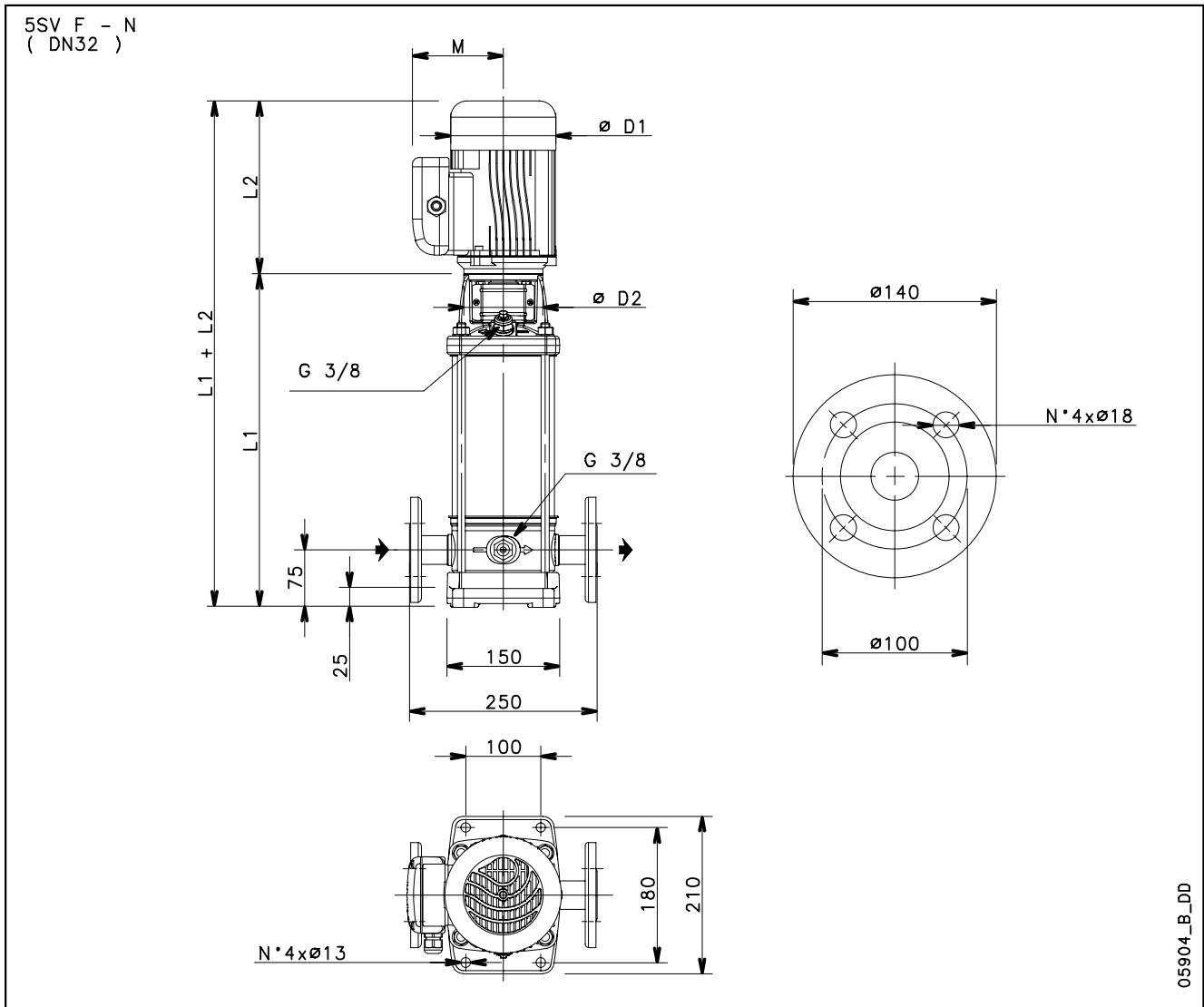

05904_B_DD

PUMP TYPE	MOTOR		DIMENSIONS (mm)								WEIGHT kg	
	kW	SIZE	L1	L2		M		D1		D2	PUMP	ELECTRIC
				1~	3~	1~	3~	1~	3~			
5SV03..L./D	1,1	80	303	263	263	137	129	155	155	120	9,4	20,8
5SV04..L./D	1,5	90	338	263	263	137	129	155	155	140	10,1	23,5
5SV05..L./D	1,5	90	363	263	263	137	129	155	155	140	10,6	24
5SV06..L..	2,2	90	388	298	298	151	134	174	174	140	11,1	29,3
5SV07..L..	2,2	90	413	298	298	151	134	174	174	140	11,6	29,8
5SV08..L..	2,2	90	438	298	298	151	134	174	174	140	12,1	30,2
5SV09..L..	3	100	473	-	298	-	134	-	174	160	13	34
5SV10..L..	3	100	498	-	298	-	134	-	174	160	13,5	34,4
5SV11..L..	3	100	523	-	298	-	134	-	174	160	13,9	34,9
5SV12..L..	4	112	548	-	319	-	154	-	197	160	14,4	40,8
5SV13..L..	4	112	573	-	319	-	154	-	197	160	14,9	41,2
5SV14..L..	4	112	598	-	319	-	154	-	197	160	15,3	41,7
5SV15..L..	4	112	623	-	319	-	154	-	197	160	15,8	42,2
5SV16..L..	4	112	648	-	319	-	154	-	197	160	16,3	42,6
5SV17..L..	5,5	132	693	-	375	-	168	-	214	300	20,7	58,2
5SV19..L..	5,5	132	743	-	375	-	168	-	214	300	21,6	59,2
5SV21..L..	5,5	132	793	-	375	-	168	-	214	300	22,6	60,1
5SV23..L..	7,5	132	843	-	367	-	191	-	256	300	23	79

**5SV..L SERIES - LOW NPSH
OPERATING CHARACTERISTICS AT 60 Hz, 2-POLE**

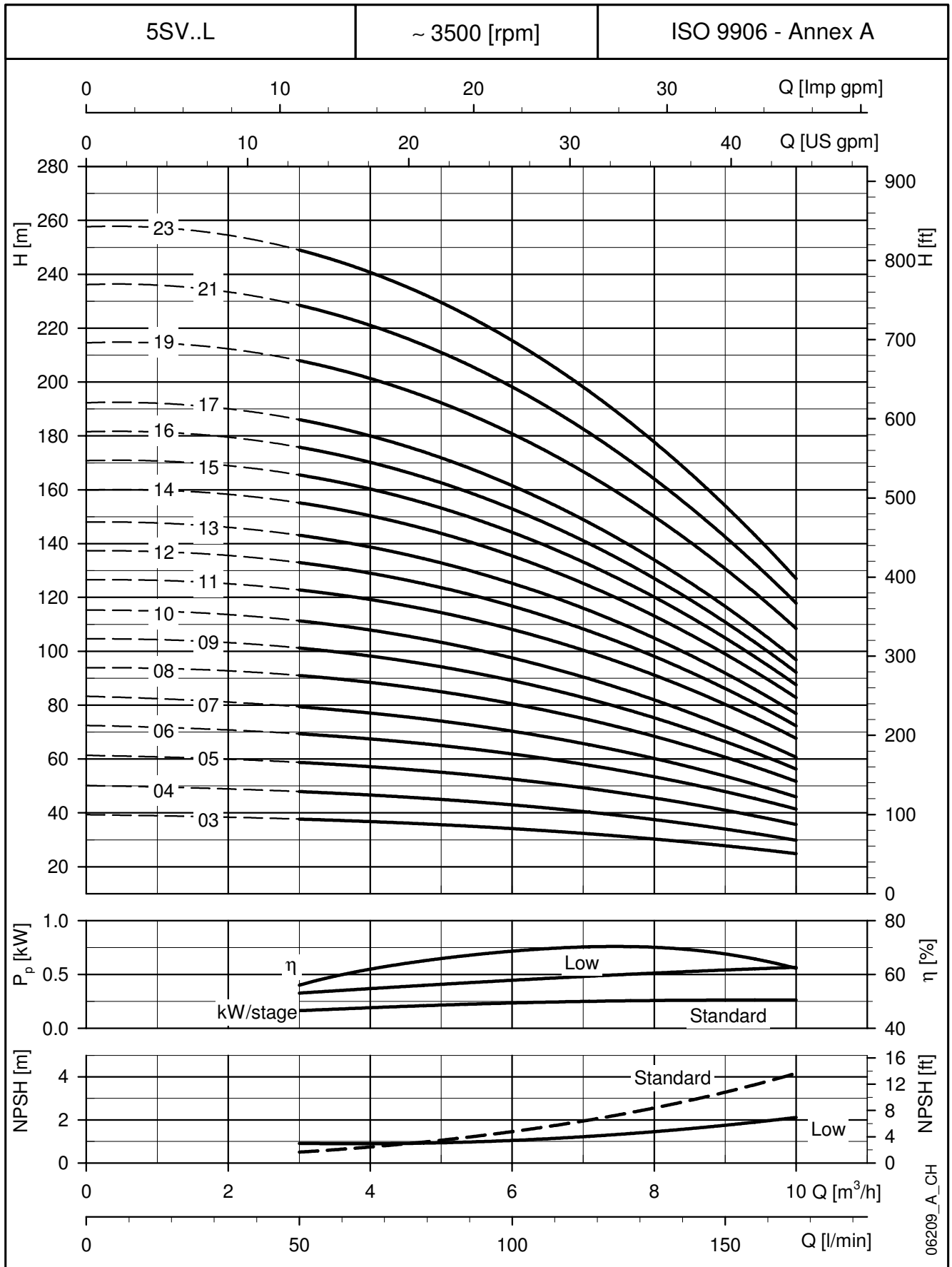

These performances are valid for liquids with density $\rho = 1.0 \text{ Kg/dm}^3$ and kinematic viscosity $\nu = 1 \text{ mm}^2/\text{sec}$.

10SV..L SERIES - LOW NPSH DIMENSIONS AND WEIGHTS AT 60 Hz, 2-POLE

LOW NPSH 60Hz

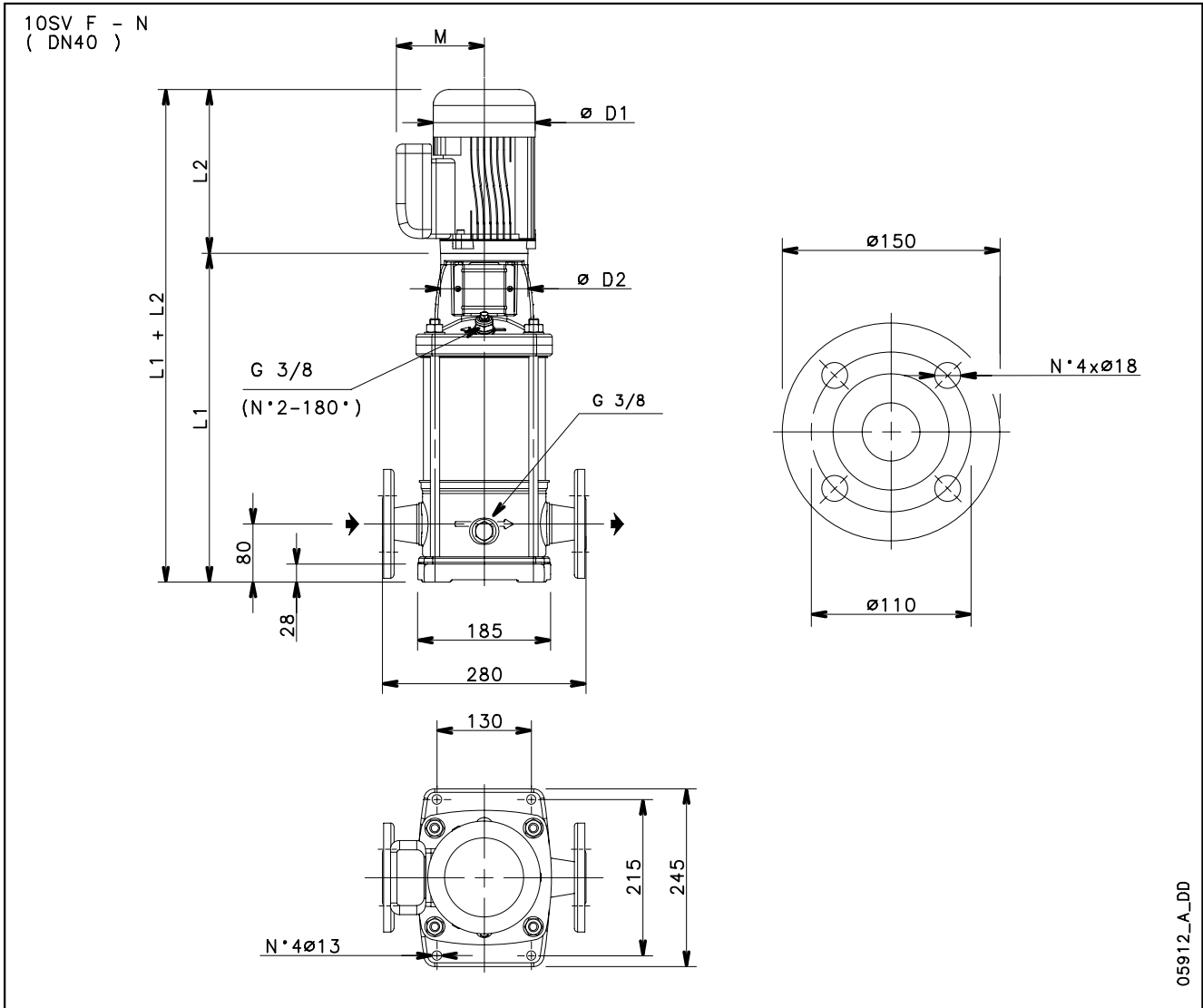

05912_A_DD

PUMP TYPE	MOTOR		DIMENSIONS (mm)								WEIGHT kg	
	kW	SIZE	L1	L2		M		D1		D2	PUMP	ELECTRIC
				1 ~	3 ~	1 ~	3 ~	1 ~	3 ~			
10SV03..L..	3	100	409	-	298	-	134	-	174	160	17,5	38,5
10SV04..L..	3	100	441	-	298	-	134	-	174	160	18,4	39,4
10SV05..L..	4	112	473	-	319	-	154	-	197	160	19,3	45,7
10SV06..L..	5,5	132	572	-	375	-	214	-	214	300	25	62,6
10SV07..L..	5,5	132	604	-	375	-	168	-	214	300	26	63,5
10SV08..L..	5,5	132	636	-	375	-	168	-	214	300	26,9	64,5
10SV09..L..	7,5	132	668	-	367	-	191	-	256	300	27,9	83,6
10SV10..L..	7,5	132	700	-	367	-	191	-	256	300	28,8	84,5
10SV11..L..	7,5	132	732	-	367	-	191	-	256	300	29,7	85,5
10SV13..L..	11	160	826	-	428	-	191	-	256	350	34,4	105
10SV15..L..	11	160	890	-	428	-	191	-	256	350	36,3	107

**10SV..L SERIES - LOW NPSH
OPERATING CHARACTERISTICS AT 60 Hz, 2-POLE**

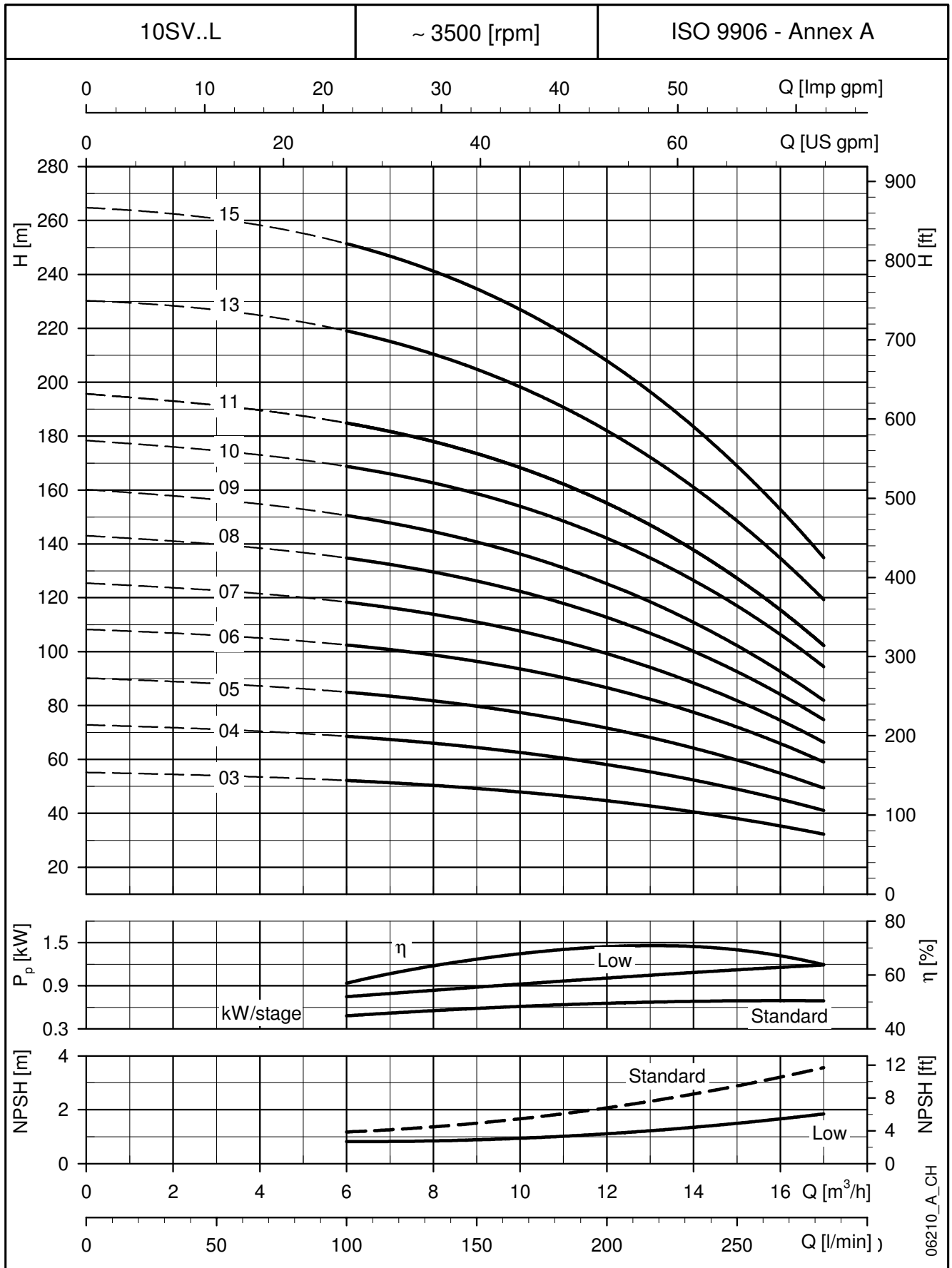

LOW NPSH 60Hz

These performances are valid for liquids with density $\rho = 1.0 \text{ Kg/dm}^3$ and kinematic viscosity $\nu = 1 \text{ mm}^2/\text{sec}$.

15SV..L SERIES - LOW NPSH DIMENSIONS AND WEIGHTS AT 60 Hz, 2-POLE

LOW NPSH 60Hz

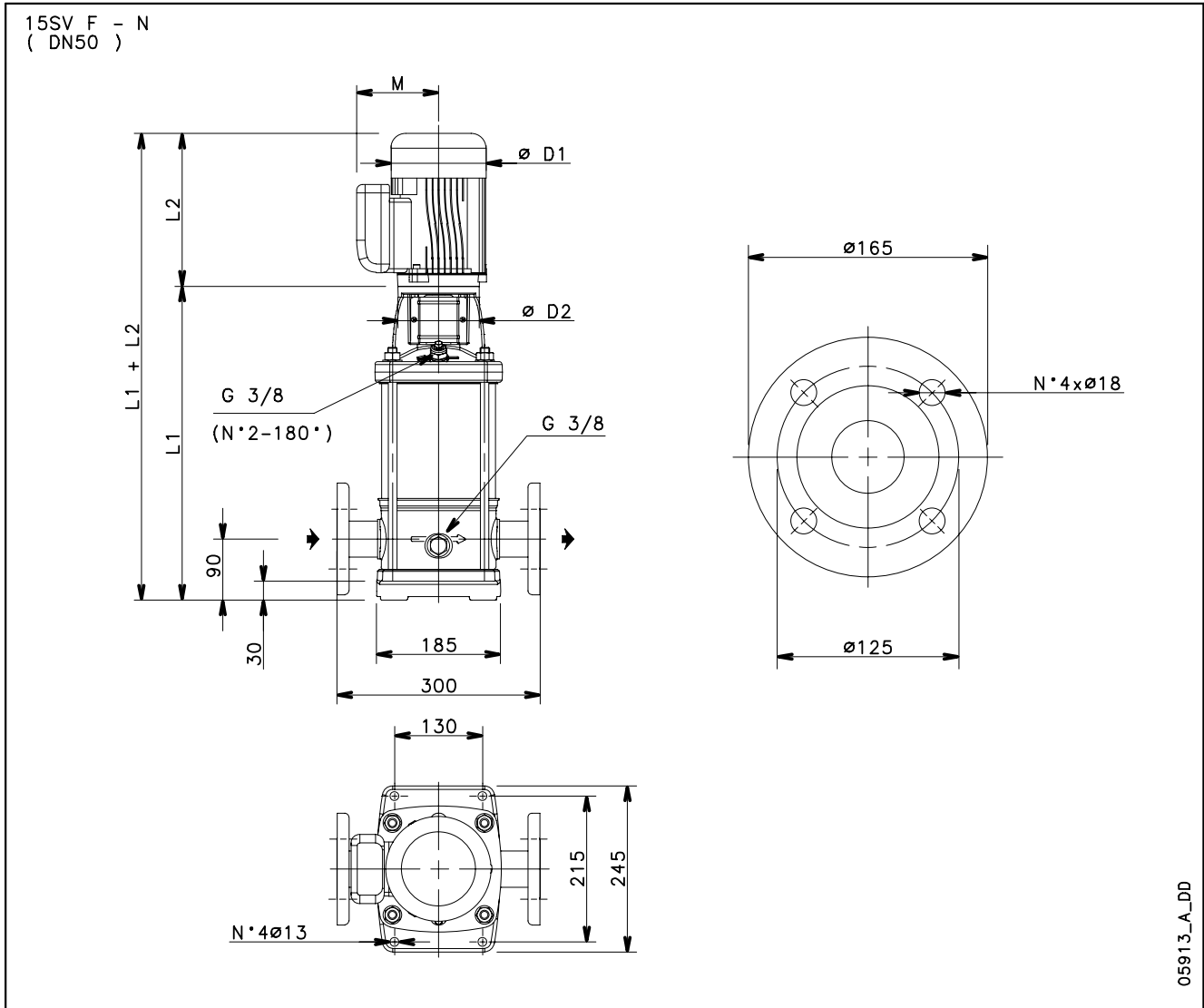

PUMP TYPE	MOTOR		DIMENSIONS (mm)					WEIGHT kg	
	kW	SIZE	L1	L2	M	D1	D2	PUMP	ELECTRIC PUMP
15SV02..L..	4	112	419	319	154	174	160	18	44,4
15SV03..L..	5,5	132	534	375	168	214	300	24	61,6
15SV04..L..	7,5	132	582	367	191	256	300	25,2	81
15SV05..L..	11	160	660	428	191	256	350	29,3	100
15SV06..L..	11	160	708	428	191	256	350	30,6	101
15SV07..L..	11	160	756	428	191	256	350	32	103
15SV08..L..	15	160	804	494	240	313	350	33,3	136
15SV09..L..	15	160	852	494	240	313	350	34,6	137
15SV10..L..	15	160	900	494	240	313	350	36	138
15SV11..L..	18,5	160	948	494	240	313	350	37,3	148
15SV12..L..	18,5	160	996	494	240	313	350	38,6	150

**15SV..L SERIES - LOW NPSH
OPERATING CHARACTERISTICS AT 60 Hz, 2-POLE**

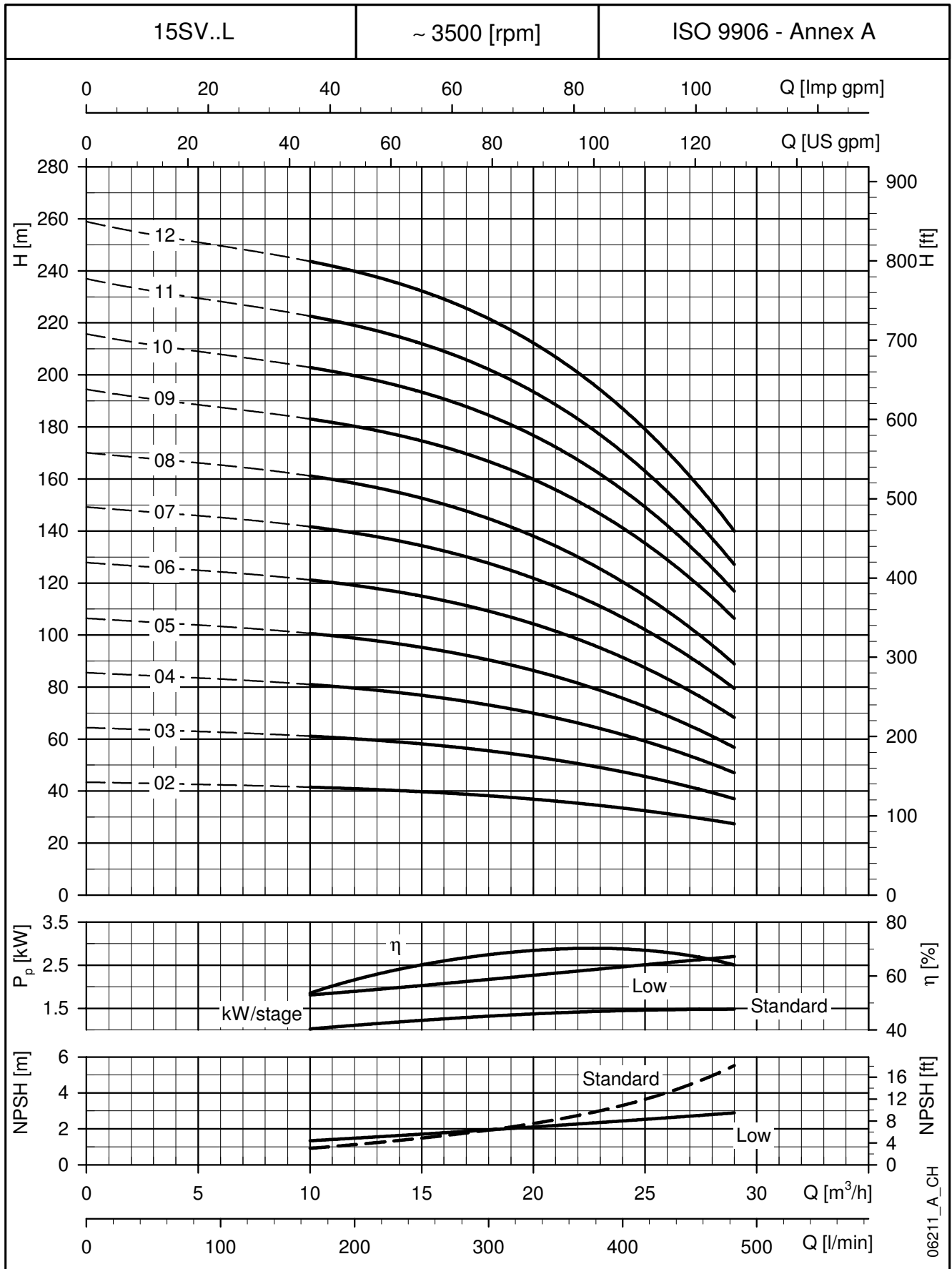

These performances are valid for liquids with density $\rho = 1.0 \text{ Kg/dm}^3$ and kinematic viscosity $\nu = 1 \text{ mm}^2/\text{sec}$.

22SV..L SERIES - LOW NPSH DIMENSIONS AND WEIGHTS AT 60 Hz, 2-POLE

LOW NPSH 60Hz

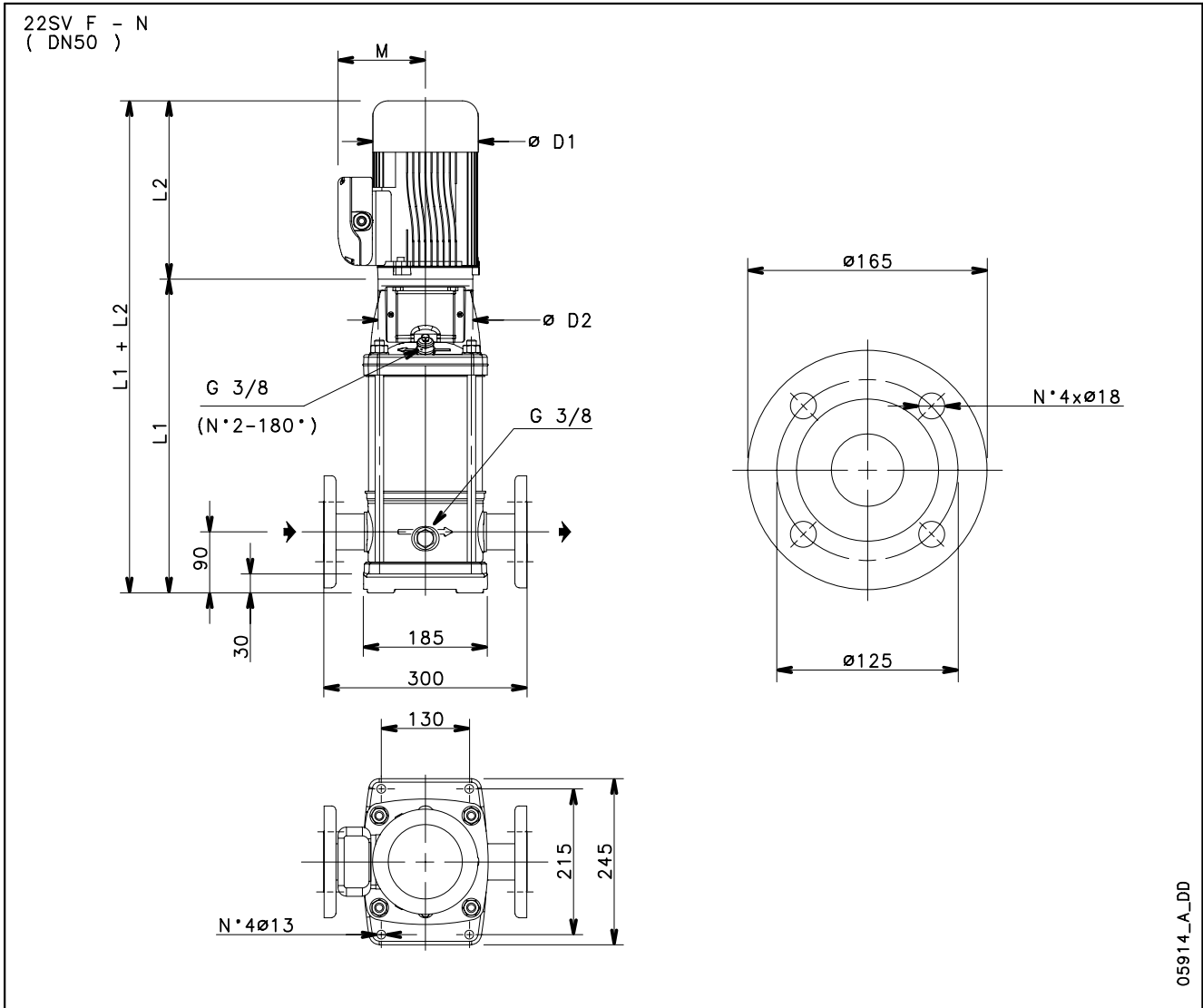

PUMP TYPE	MOTOR		DIMENSIONS (mm)					WEIGHT kg	
	kW	SIZE	L1	L2	M	D1	D2	PUMP	ELECTRIC PUMP
22SV02..L..	5,5	132	486	375	168	214	300	23	61
22SV03..L..	7,5	132	534	367	191	256	300	24,3	80
22SV04..L..	11	160	612	428	191	256	350	28,5	99
22SV05..L..	11	160	660	428	191	256	350	29,8	100
22SV06..L..	15	160	708	494	240	313	350	31,1	133
22SV07..L..	15	160	756	494	240	313	350	32,4	135
22SV08..L..	15	160	804	494	240	313	350	33,8	136
22SV09..L..	18,5	160	852	494	240	313	350	35,1	146
22SV10..L..	22	180	900	494	240	313	350	36,4	158

**22SV..L SERIES - LOW NPSH
OPERATING CHARACTERISTICS AT 60 Hz, 2-POLE**

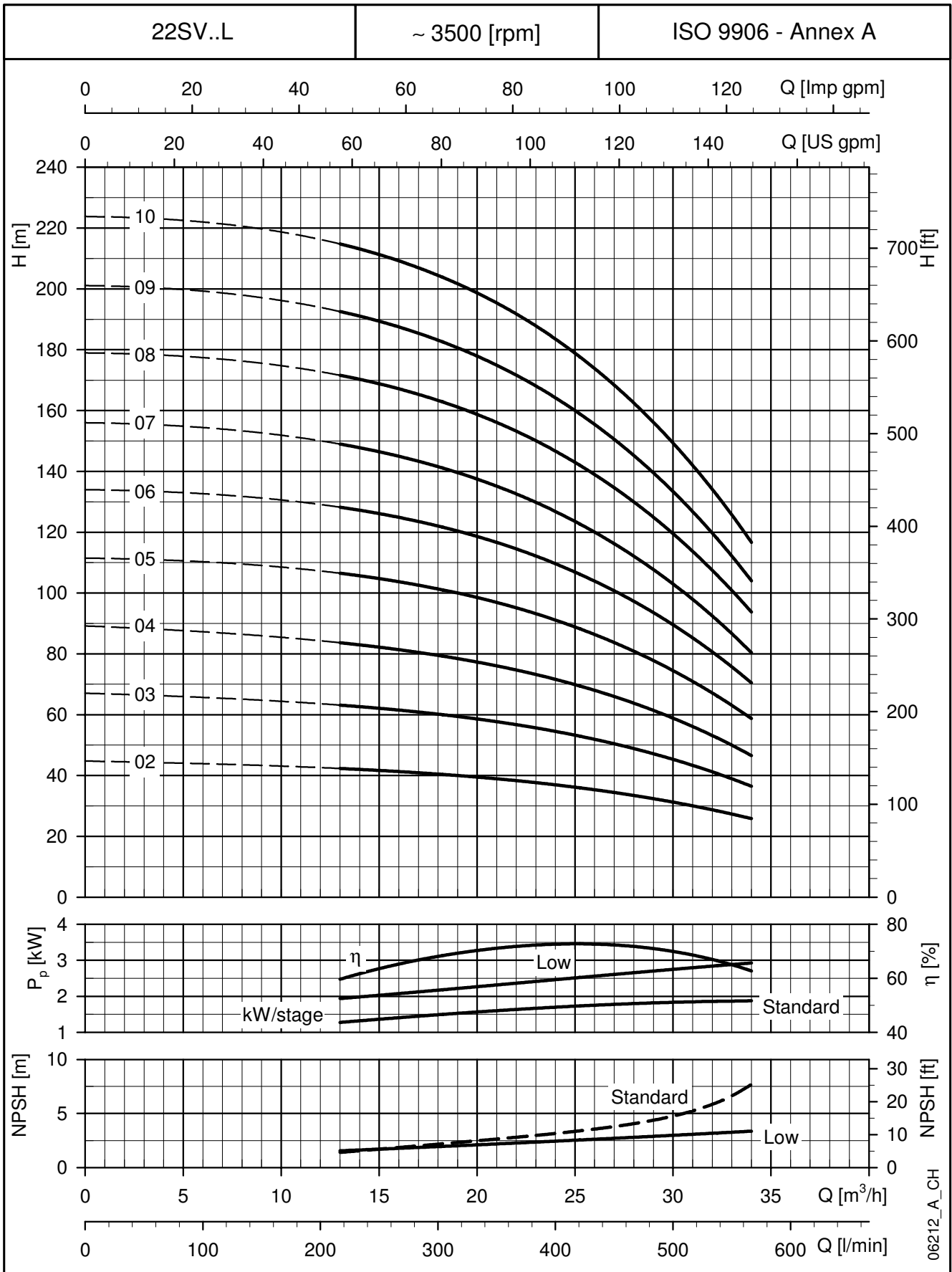

LOW NPSH 60Hz

These performances are valid for liquids with density $\rho = 1.0 \text{ Kg/dm}^3$ and kinematic viscosity $\nu = 1 \text{ mm}^2/\text{sec}$.

33SV..L SERIES - LOW NPSH DIMENSIONS AND WEIGHTS AT 60 Hz, 2-POLE

LOW NPSH

60Hz

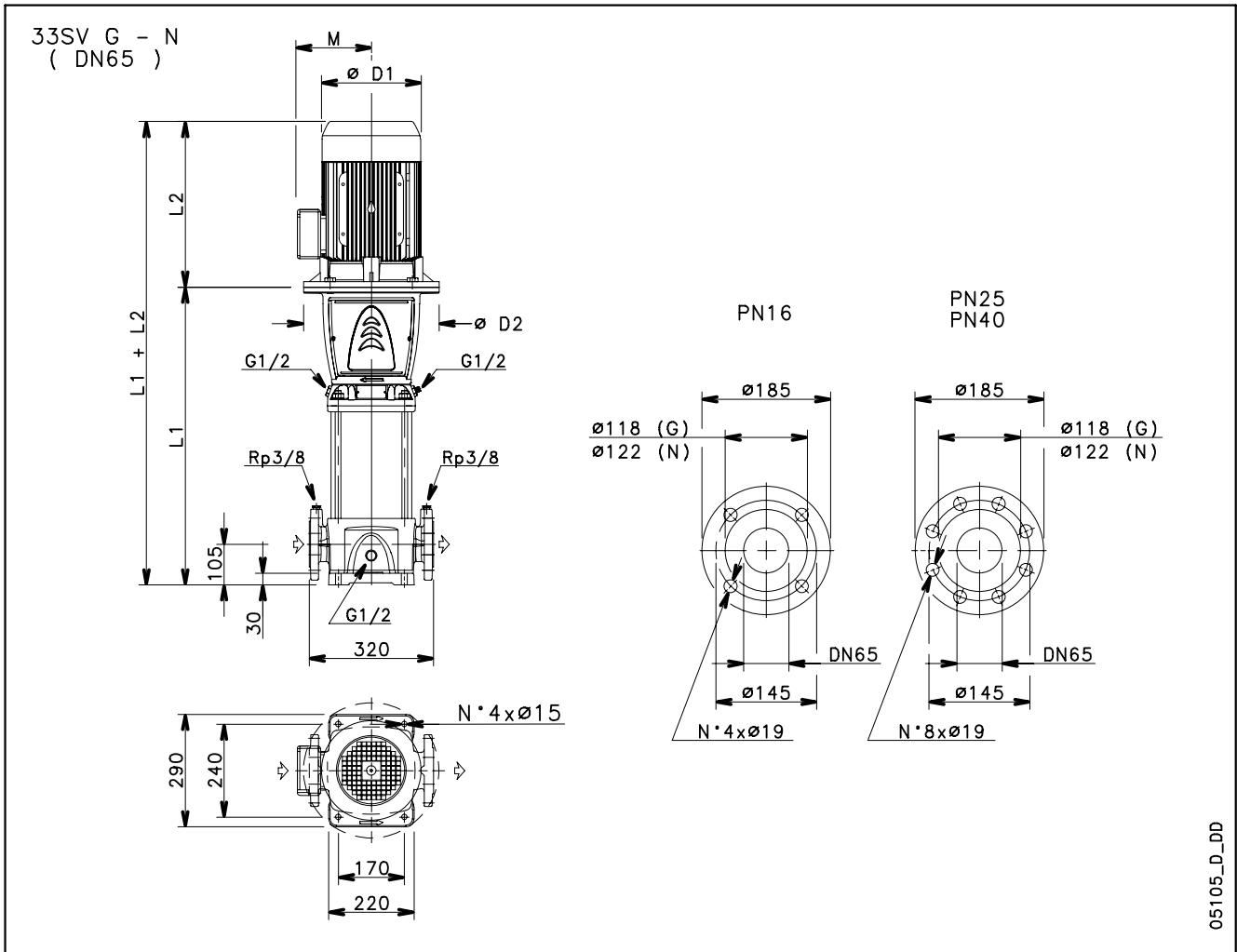

PUMP TYPE	MOTOR		DIMENSIONS (mm)							WEIGHT kg	
	kW	SIZE	L1	L2	D1	D2	M	PN	PUMP	ELECTRIC PUMP	
33SV2/1A..L..	7,5	132	584	367	256	300	191	16	61	117	
33SV2..L..	11	160	619	428	256	350	191	16	65	136	
33SV3/2A..L..	11	160	694	428	256	350	191	16	69	140	
33SV3/1A..L..	15	160	694	494	313	350	240	16	69	171	
33SV3..L..	15	160	694	494	313	350	240	16	69	171	
33SV4/2A..L..	15	160	769	494	313	350	240	16	73	175	
33SV4/1A..L..	18,5	160	769	494	313	350	240	25	73	184	
33SV4..L..	18,5	160	769	494	313	350	240	25	73	184	
33SV5/2A..L..	18,5	160	844	494	313	350	240	25	77	188	
33SV5/1A..L..	22	180	844	494	313	350	240	25	78	200	
33SV5..L..	22	180	844	494	313	350	240	25	78	200	
33SV6/2A..L..	30	200	919	657	402	400	317	25	89	304	
33SV6/1A..L..	30	200	919	657	402	400	317	25	89	304	
33SV6..L..	30	200	919	657	402	400	317	25	89	304	
33SV7/2A..L..	30	200	994	657	402	400	317	25	92	307	
33SV7/1A..L..	30	200	994	657	402	400	317	25	92	307	
33SV7..L..	30	200	994	657	402	400	317	25	92	307	

PUMP TYPE	MOTOR		DIMENSIONS (mm)							WEIGHT kg	
	kW	SIZE	L1	L2	D1	D2	M	PN	PUMP	ELECTRIC PUMP	
33SV8/2A..L..	37	200	1069	657	402	400	317	40	101	331	
33SV8/1A..L..	37	200	1069	657	402	400	317	40	101	331	
33SV8..L..	37	200	1069	657	402	400	317	40	101	331	

33SV..L SERIES - LOW NPSH OPERATING CHARACTERISTICS AT 60 Hz, 2-POLE

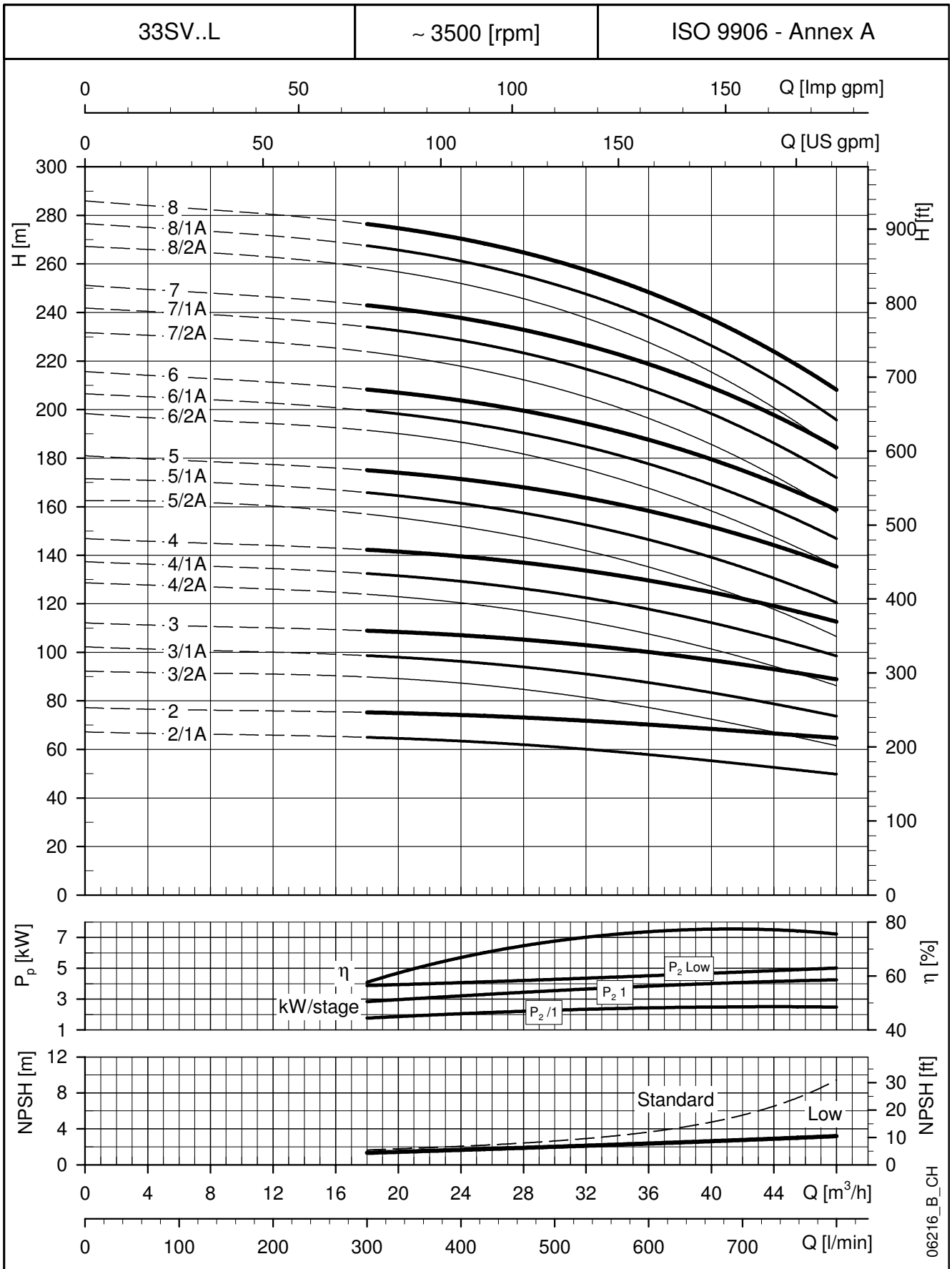

LOW NPSH
60Hz

These performances are valid for liquids with density $\rho = 1.0 \text{ Kg/dm}^3$ and kinematic viscosity $\nu = 1 \text{ mm}^2/\text{sec}$.

46SV..L SERIES - LOW NPSH DIMENSIONS AND WEIGHTS AT 60 Hz, 2-POLE

LOW NPSH 60Hz

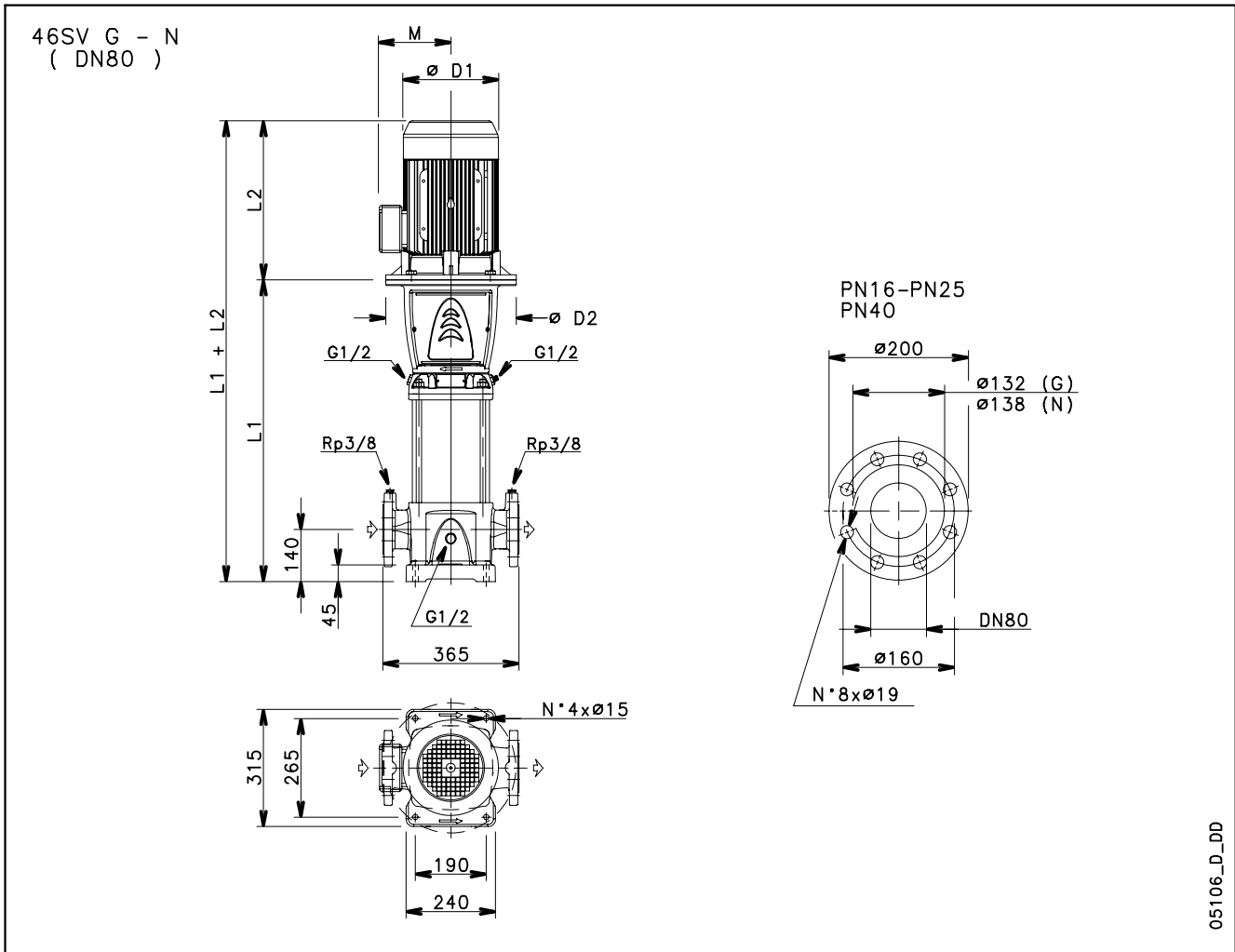

PUMP TYPE	MOTOR		DIMENSIONS (mm)						WEIGHT kg	
	kW	SIZE	L1	L2	D1	D2	M	PN	PUMP	ELECTRIC PUMP
46SV2/1A..L..	15	160	659	494	313	350	240	16	70	172
46SV2..L..	15	160	659	494	313	350	240	16	70	172
46SV3/2A..L..	18,5	160	734	494	313	350	240	16	74	185
46SV3/1A..L..	22	180	734	494	313	350	240	16	74	196
46SV3..L..	22	180	734	494	313	350	240	16	74	196
46SV4/2A..L..	30	200	809	657	402	400	317	16	86	301
46SV4/1A..L..	30	200	809	657	402	400	317	16	86	301
46SV4..L..	30	200	809	657	402	400	317	16	86	301
46SV5/2A..L..	30	200	884	657	402	400	317	25	90	305
46SV5/1A..L..	37	200	884	657	402	400	317	25	90	320
46SV5..L..	37	200	884	657	402	400	317	25	90	320
46SV6/2A..L..	37	200	959	657	402	400	317	25	94	324
46SV6/1A..L..	45	225	959	746	402	400	317	25	98	454
46SV6..L..	45	225	959	746	402	400	317	25	98	454
46SV7/2A..L..	45	225	1034	746	455	450	384	40	105	461
46SV7/1A..L..	45	225	1034	746	455	450	384	40	105	461
46SV7..L..	45	225	1034	746	455	450	384	40	105	461

**46SV..L SERIES - LOW NPSH
OPERATING CHARACTERISTICS AT 60 Hz, 2-POLE**

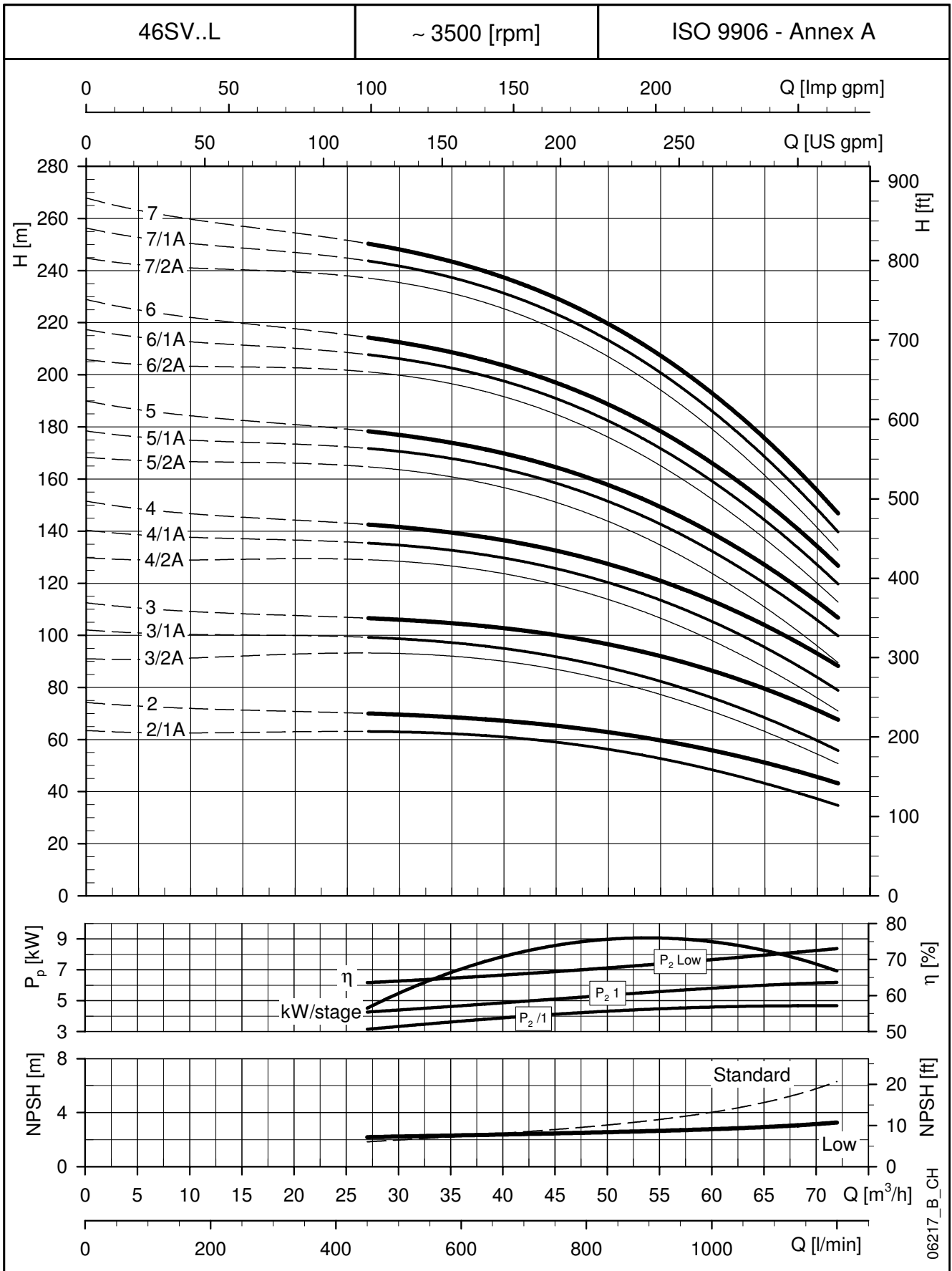

These performances are valid for liquids with density $\rho = 1.0 \text{ Kg/dm}^3$ and kinematic viscosity $\nu = 1 \text{ mm}^2/\text{sec}$.

66SV..L SERIES - LOW NPSH DIMENSIONS AND WEIGHTS AT 60 Hz, 2-POLE

LOW NPSH 60Hz

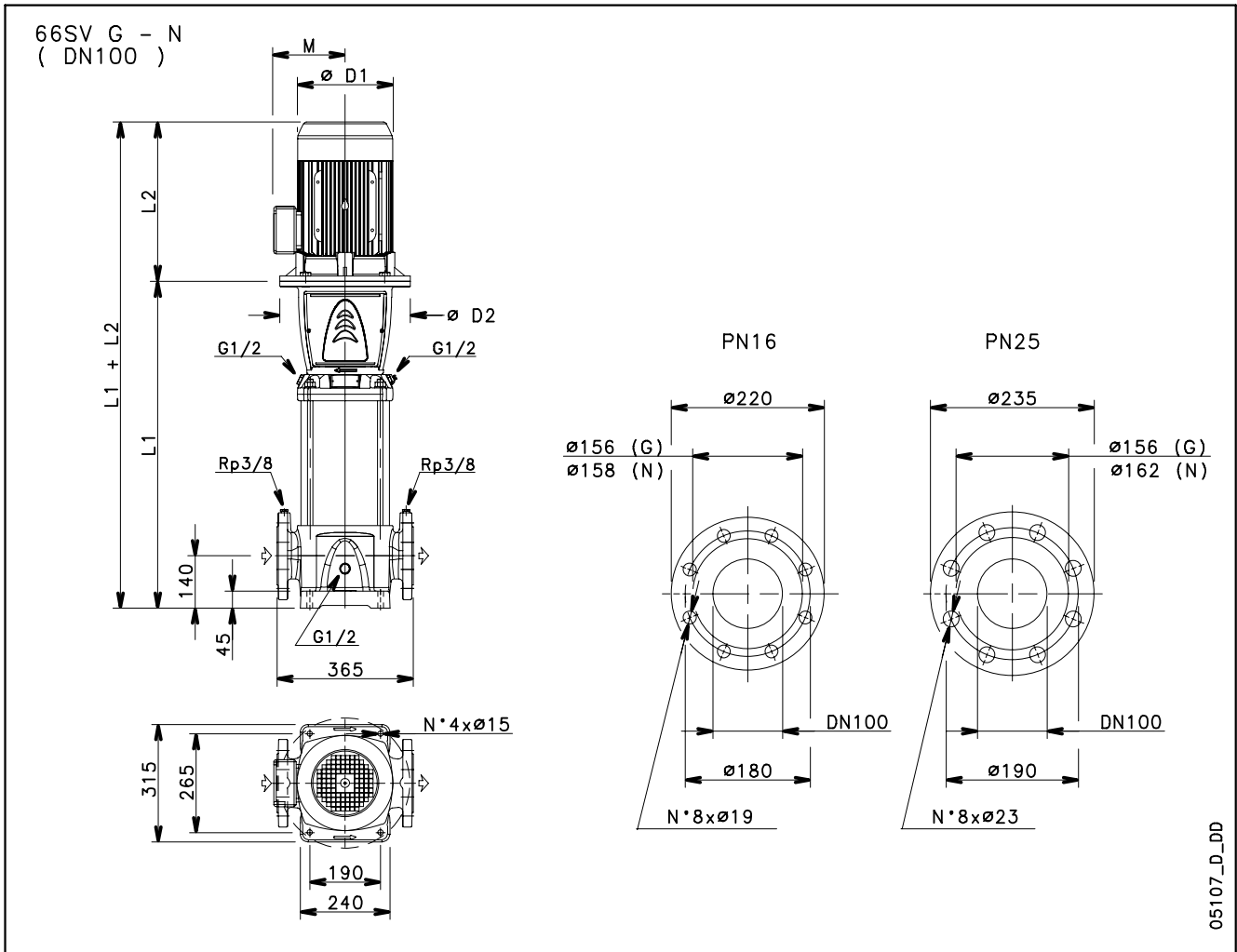

05107_D_DD

PUMP TYPE	MOTOR		DIMENSIONS (mm)						WEIGHT kg	
	kW	SIZE	L1	L2	D1	D2	M	PN	PUMP	ELECTRIC PUMP
66SV2/1A..L..	18,5	160	699	494	313	350	240	16	81	192
66SV2..L..	22	160	699	494	313	350	240	16	81	203
66SV3/2A..L..	30	200	789	657	402	400	317	16	94	309
66SV3/1A..L..	30	200	789	657	402	400	317	16	94	309
66SV3..L..	37	200	789	657	402	400	317	16	94	324
66SV4/2A..L..	37	200	879	657	402	400	317	16	100	330
66SV4/1A..L..	37	200	879	657	402	400	317	25	102	332
66SV4..L..	45	225	879	746	455	450	384	25	106	462
66SV5/2A..L..	45	225	969	746	455	450	384	25	111	467

66sv-L-2p60-en_b_td

**66SV..L SERIES - LOW NPSH
OPERATING CHARACTERISTICS AT 60 Hz, 2-POLE**

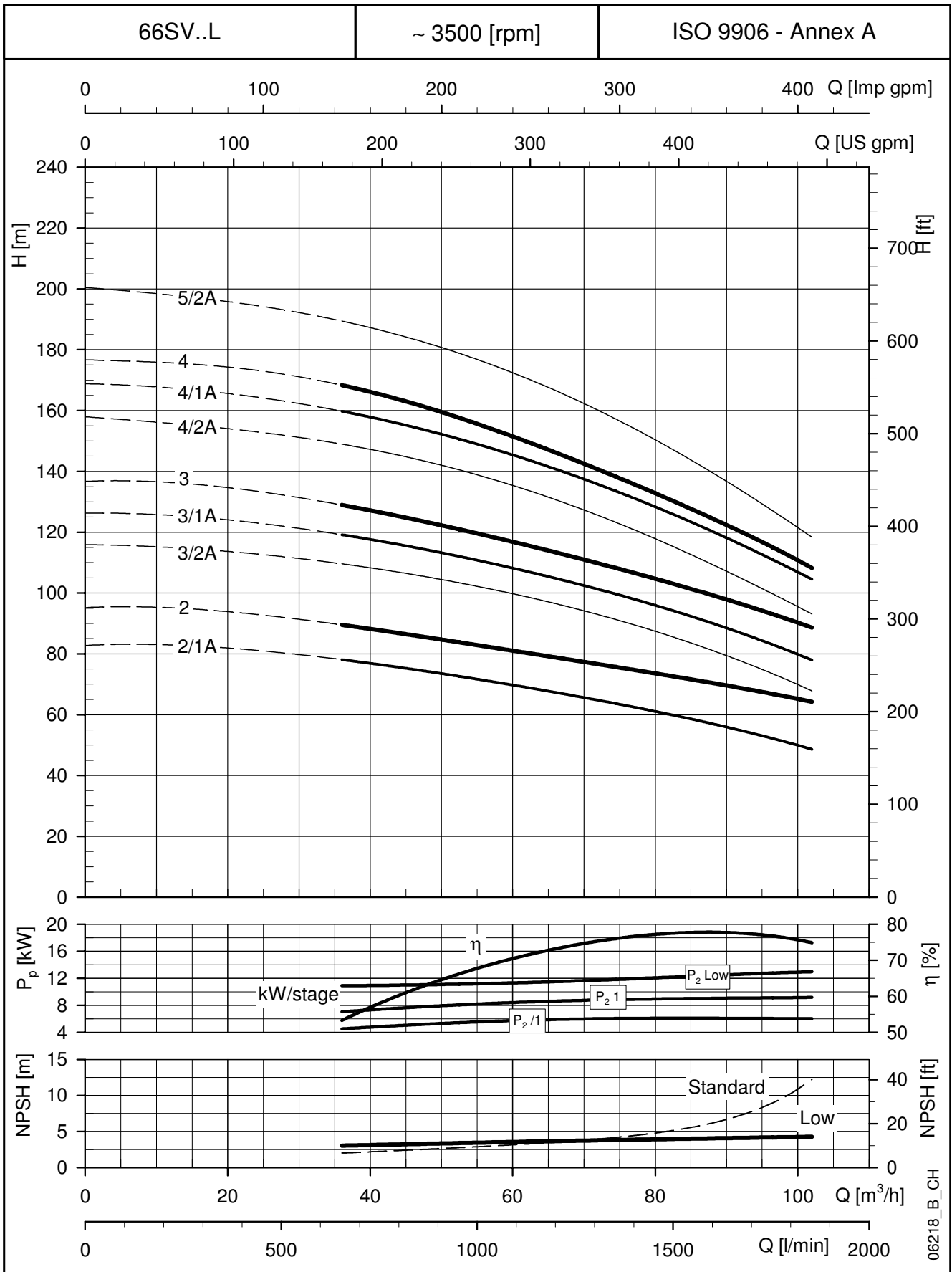

**LOW NPSH
60Hz**

These performances are valid for liquids with density $\rho = 1.0 \text{ Kg/dm}^3$ and kinematic viscosity $\nu = 1 \text{ mm}^2/\text{sec}$.

**LOW
NPSH**

60Hz

**HIGH
TEMPERATURE
150°C
(50/60 Hz)**

e-SV™ SERIES - HIGH TEMPERATURE (150°C) 50/60 Hz

Background e contesto

In industrial applications pumps often have to deal with liquids at high temperatures in order to optimise performance for each production process. In these applications, pumps frequently need to be protected from excessive temperatures for the purpose of maintaining high performance levels. That's why Lowara has developed the e-SV™ High Temperature 150°C series: this sturdy pump integrates a mechanical seal normalised with suitable materials for pumping liquids at high temperatures.

Benefits of the e-SV™ High Temperature 150°C series

Long-term mechanical seal performance:

Thanks to the special design of its housing, the seal is protected from the stress caused by high temperatures by means of a "natural" lubrication process which is triggered by the pumped liquid itself. Furthermore, the balanced mechanical seal and the high quality of the elastomers used in the e-SV™ High Temperature 150°C series assure excellent long-term performance, even in the harshest operating conditions.

Solidity: e-SV™ High Temperature 150°C pumps are hard-wearing thanks to the hard metal bush supports which can withstand high temperature applications up to 150°C and pressure values up to PN25 (see the pressure-temperature diagram).

Easy and cost-effective maintenance:

the mechanical seal installed in e-SV™ High Temperature 150°C pumps is a standard balanced mechanical seal (EN12756) which makes it cheap and easy to replace.

Identification code

e-SV™ High Temperature 150°C models are identified by the letter "**H**" in the standard identification code of the e-SV™ product range.

Available in the following versions:

FH in AISI 304 (for 1-22SV).

GH in AISI 304/Cast iron (for 33-125SV).

NH in AISI 316 (for all versions).

Example: 3SV13**FH**015T

H = High Temperature 150°C.



Special features / benefits

- **Special design of the mechanical seal chamber** for high temperature applications.
- **Easy-to-replace standard mechanical seal** (EN12756) on all models from 5,5 kW for easy maintenance **without removing the motor**.
- **Hard metal intermediate bush support** (tungsten carbide) to increase the duration and capability of operating in extreme conditions, available on all sizes.
- **Balanced impeller design** to reduce axial thrust and extend the lifetime of standard motor bearings.
- **IE2/IE3 standard motors**, three-phase, 2-pole, from 0,75 kW to 55 kW with fixed bearing **to endure extreme thrusts without limiting inlet pressure**.

Special configurations

A wide range of configurations is available for e-SV™ High Temperature 150°C pumps:

- Materials used. See the "Materials" section.
- Options for mechanical seals and rubber gaskets. See the "Mechanical seals and rubber gaskets" section.
- Motor and configuration options. See the "Motor" section.

**e-SV™ SERIES - HIGH TEMPERATURE (150°C)
50/60 Hz**

Technical specifications - Design

- 1: Special design of the mechanical seal chamber, assuring adequate lubrication triggered by the pumped liquid, thus extending product lifetime.
- 2: Balanced mechanical seal in order to withstand high pressures and temperatures.

Operating characteristics

For the hydraulic performances, please refer to the standard catalogue of e-SV™.

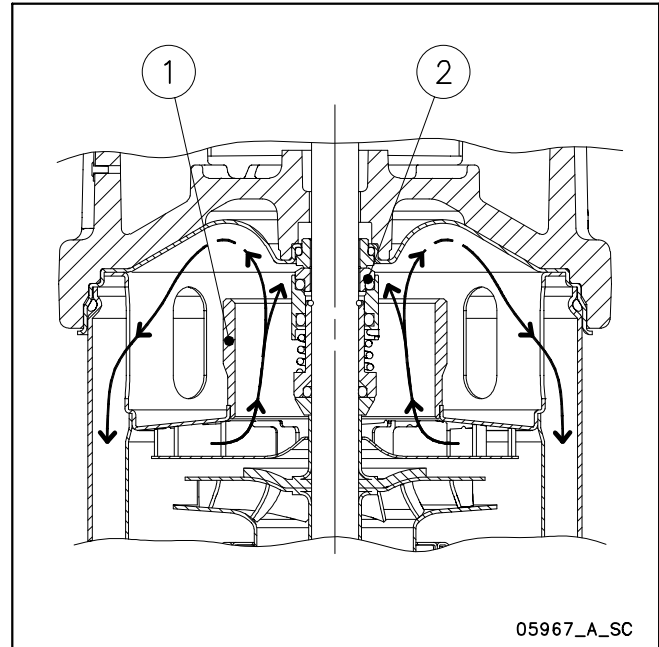

→ Route of pumped liquid.

**HIGH
TEMPERATURE**

**e-SV™ SERIES - HIGH TEMPERATURE (150°C) 50/60 Hz
ELECTRIC PUMP CROSS SECTION AND MAIN COMPONENTS**

HIGH TEMPERATURE

05960_A_DS

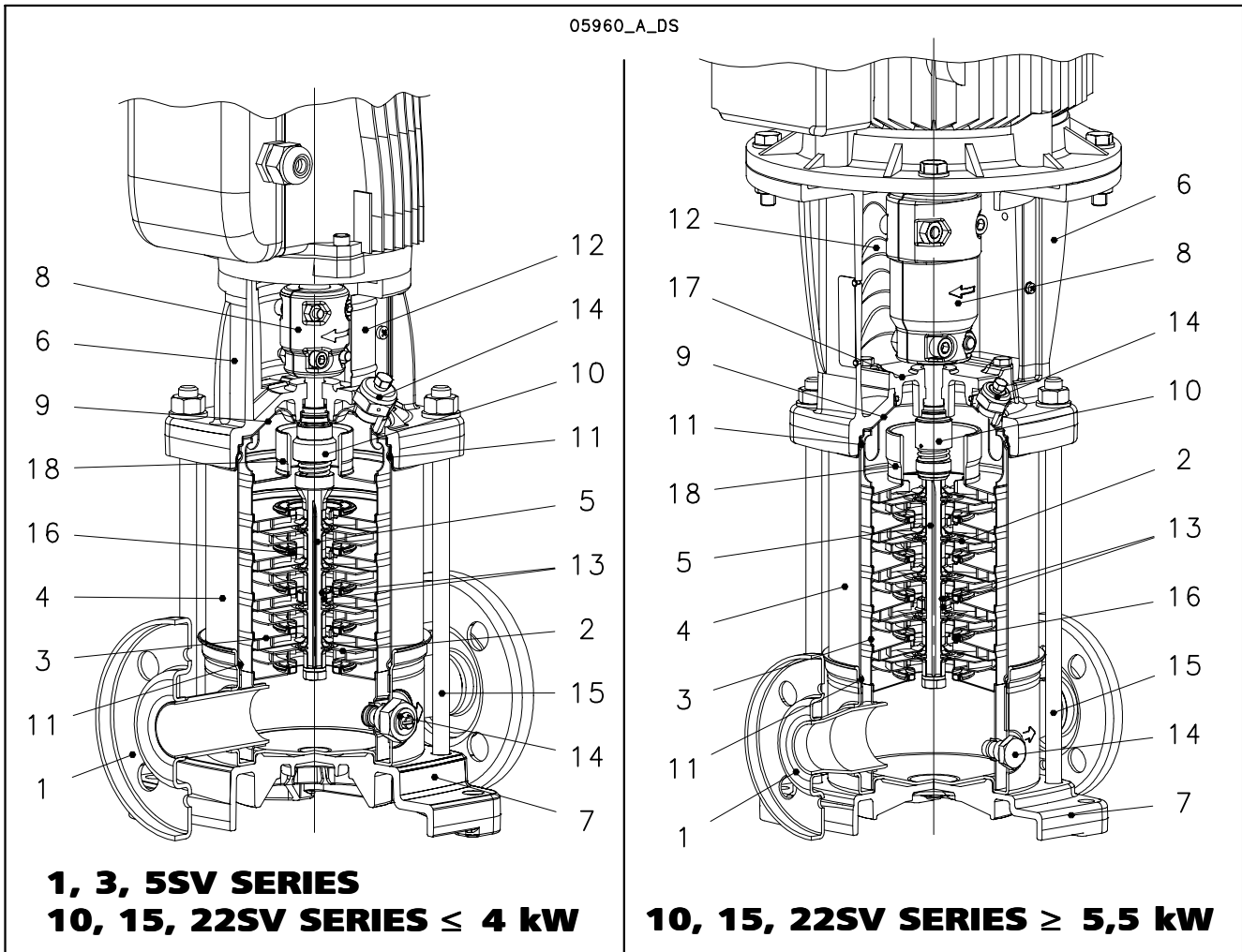

**1, 3, 5SV SERIES
10, 15, 22SV SERIES ≤ 4 kW**

10, 15, 22SV SERIES ≥ 5,5 kW

H VERSIONS

REF.	NAME	FH VERSION			NH VERSION		
		MATERIAL	REFERENCE STANDARDS		MATERIAL	REFERENCE STANDARDS	
N.			EUROPE	USA		EUROPE	USA
1	Pump body	Stainless steel	1.4301	AISI 304	Stainless steel	1.4404	AISI 316L
2	Impeller	Stainless steel	1.4301	AISI 304	Stainless steel	1.4404	AISI 316L
3	Diffuser	Stainless steel	1.4301	AISI 304	Stainless steel	1.4404	AISI 316L
4	Outer sleeve	Stainless steel	1.4301	AISI 304	Stainless steel	1.4404	AISI 316L
5	Shaft	Stainless steel	1.4301	AISI 304	Stainless steel	1.4401	AISI 316
6	Adapter	Cast iron	EN-JL1040	ASTM Class 35	Cast iron	EN-JL1040	ASTM Class 35
7	Base	Aluminium	AC46100	-	Aluminium	AC46100	-
8	Coupling	Aluminium	AC46100	-	Aluminium	AC46100	-
9	Seal plate	Stainless steel	1.4301	AISI 304	Stainless steel	1.4404	AISI 316L
10	Mechanical seal	Silicon carbide / Carbon / EPDM			Silicon carbide / Carbon / EPDM		
11	Elastomers	EPDM			EPDM		
12	Coupling protection	Stainless steel	1.4301	AISI 304	Stainless steel	1.4301	AISI 304
13	Shaft sleeve and bushing	Tungsten carbide			Tungsten carbide		
14	Fill / drain plugs	Stainless steel	1.4301	AISI 304	Stainless steel	1.4401	AISI 316
15	Tie rods	Galvanized steel	1.0765		Stainless steel	1.4057	AISI 431
16	Wear ring	Technopolymer PPS			Technopolymer PPS		
17	Seal housing	Stainless steel	1.4308	AISI 304	Stainless steel	1.4408	AISI 316
18	Final Diffuser	Stainless steel	1.4404	AISI 316L	Stainless steel	1.4404	AISI 316L

1-22sv-FH_NH-en_a_tm

**e-SV™ SERIES - HIGH TEMPERATURE (150°C) 50/60 Hz
ELECTRIC PUMP CROSS SECTION AND MAIN COMPONENTS**

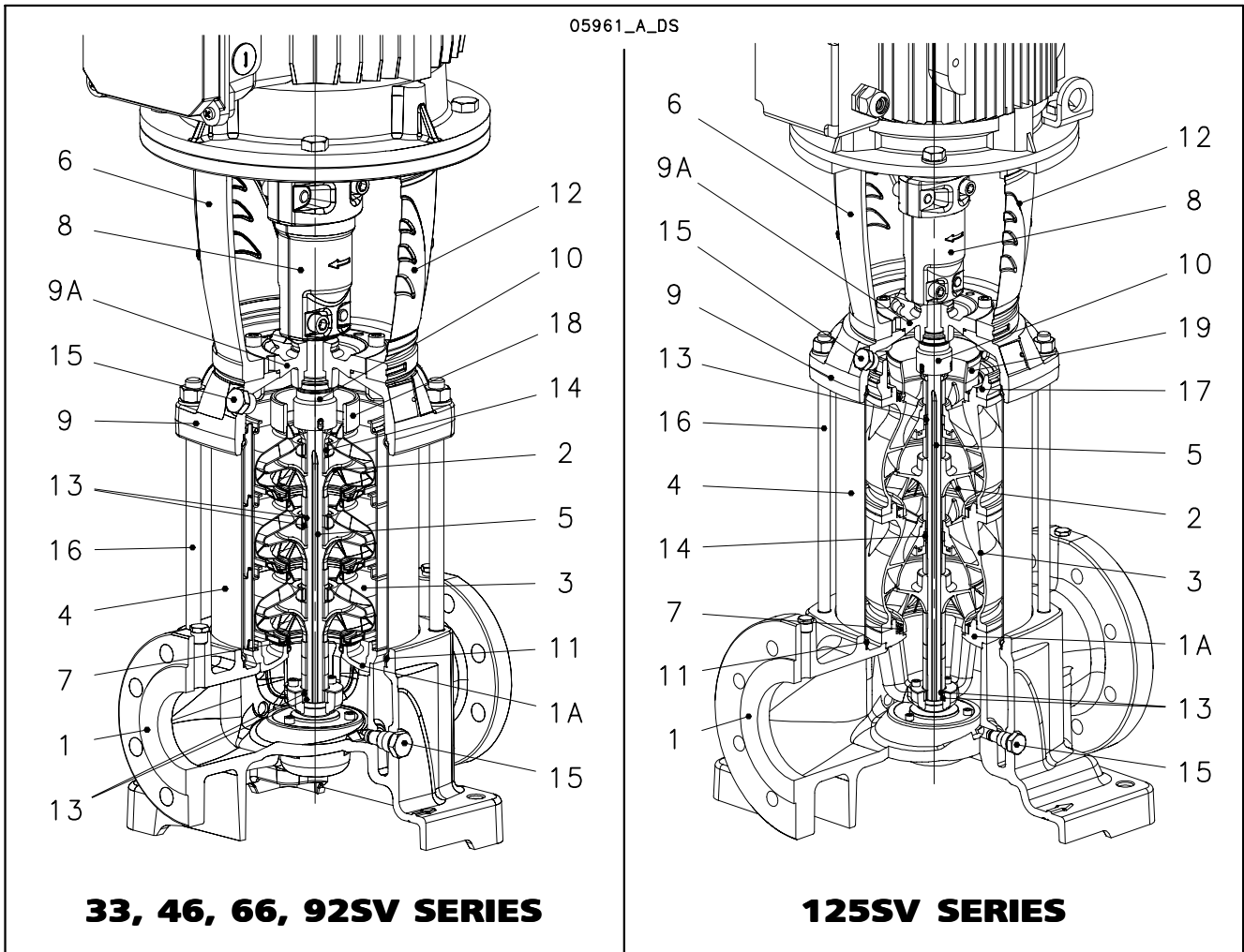

HIGH TEMPERATURE

H VERSIONS

REF.	NAME	GH VERSION			NH VERSION		
		MATERIAL	REFERENCE STANDARDS		MATERIAL	REFERENCE STANDARDS	
N.			EUROPE	USA		EUROPE	USA
1	Pump body	Cast iron	EN-JL1040	ASTM Class 35	Stainless steel	1.4408	AISI 316
1A	Lower support 33-92SV	Cast iron	EN-JL1040	ASTM Class 35	Stainless steel	1.4408	AISI 316
1A	Lower support 125SV	Stainless steel	1.4308	AISI 304	Stainless steel	1.4408	AISI 316
2	Impeller 33-92SV	Stainless steel	1.4404	AISI 316L	Stainless steel	1.4404	AISI 316L
3	Diffuser 33-92SV	Stainless steel	1.4301	AISI 304	Stainless steel	1.4404	AISI 316L
2-3	Impeller, Diffuser 125SV	Stainless steel	1.4308	AISI 304	Stainless steel	1.4408	AISI 316
4	Outer sleeve	Stainless steel	1.4301	AISI 304	Stainless steel	1.4404	AISI 316L
5	Shaft	Stainless steel	1.4057	AISI 431	Stainless steel	1.4462	UNS S 31803
6	Adapter	Cast iron	EN-JL1030	ASTM Class 25	Cast iron	EN-JL1030	ASTM Class 25
6	Adapter (for 55kW)	Cast iron	EN-JS1050	ASTM A 536 80-55-06	Cast iron	EN-JS1050	ASTM A 536 80-55-06
7	Wear ring	Technopolymer PPS			Technopolymer PPS		
8	Coupling	Cast iron	EN-JL1030	ASTM Class 25	Cast iron	EN-JL1030	ASTM Class 25
8	Coupling (for 55kW)	Cast iron	EN-JS1050	ASTM A 536 80-55-06	Cast iron	EN-JS1050	ASTM A 536 80-55-06
9-9A	Upper head, Seal housing	Cast iron	EN-JL1040	ASTM Class 35	Stainless steel	1.4408	AISI 316
10	Mechanical seal	Silicon carbide / Carbon / EPDM			Silicon carbide / Carbon / EPDM		
11	Elastomers	EPDM			EPDM		
12	Coupling protection	Stainless steel	1.4301	AISI 304	Stainless steel	1.4301	AISI 304
13	Shaft sleeve and bushing	Tungsten carbide			Tungsten carbide		
14	Bushing for diffuser	Carbon			Carbon		
15	Fill / drain / air plugs	Stainless steel	1.4401	AISI 316	Stainless steel	1.4401	AISI 316
16	Tie rods	Galvaniz. steel	1.0765	-	Stainless steel	1.4057	AISI 431
17	Adapter ring	Stainless steel	1.4308	AISI 304	Stainless steel	1.4408	AISI 316
18	Final Diffuser	Stainless steel	1.4404	AISI 316L	Stainless steel	1.4404	AISI 316L
19	Conveyor	Stainless steel	1.4401	AISI 316	Stainless steel	1.4401	AISI 316

**e-SV™ SERIES - HIGH TEMPERATURE (150°C) 50/60 Hz
BALANCED MECHANICAL SEALS, ACCORDING TO EN 12756**

HIGH TEMPERATURE

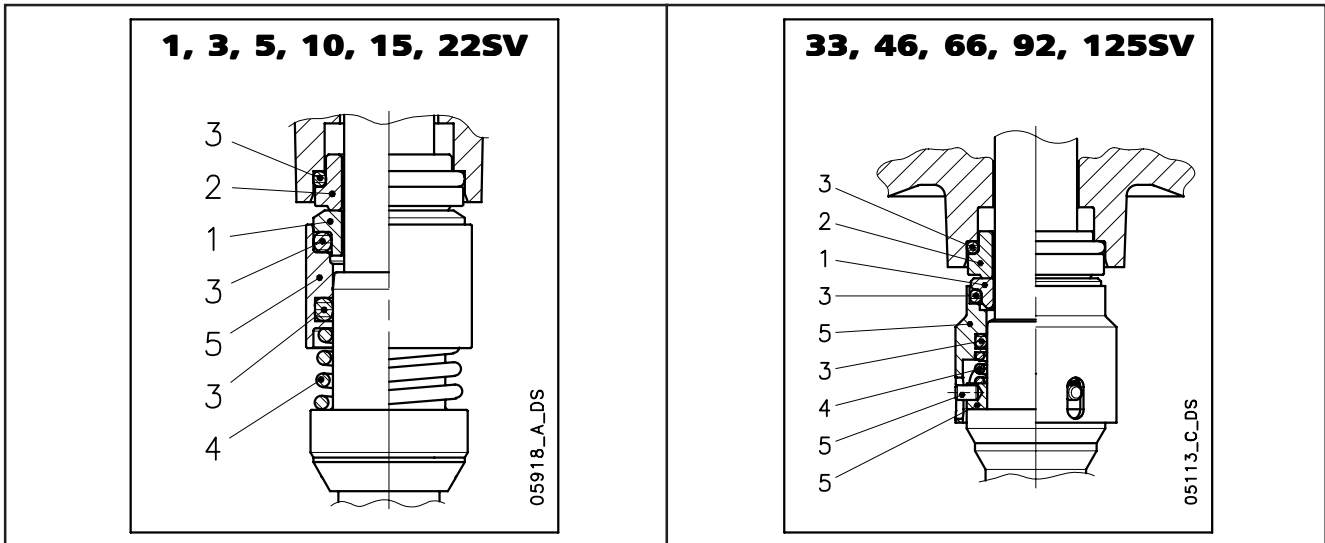

LIST OF MATERIALS

POSITION 1 - 2	POSITION 3	POSITION 4 - 5
Q ₁ : Silicon Carbide	E : EPDM	G : AISI 316
A : Carbon metal-impregnated	V : FPM	

TYPE OF SEAL

sv-at_ten-mec-en_a_tm

TYPE	POSITION					TEMPERATURE (°C)
	1 ROTATING PART	2 STATIONARY PART	3 ELASTOMERS	4 SPRINGS	5 OTHER COMPONENTS	
MECHANICAL SEAL FOR USE WITH WATER						
Q ₁ A E G G	Q ₁	A	E	G	G	-30 +150
OTHER TYPES OF AVAILABLE MECHANICAL SEAL						
Q ₁ A V G G	Q ₁	A	V	G	G	-10 +150
*Q ₁ Q ₁ V G G	Q ₁	Q ₁	V	G	G	-10 +150

* Versions with anti-rotation lock pin of the fixed part.

sv-at_tipi-ten-mec-en_a_tc

**PRESSURE/TEMPERATURE APPLICATION LIMITS FOR COMPLETE PUMP
(APPLICABLE WITH ANY OF THE SEALS LISTED ABOVE)**

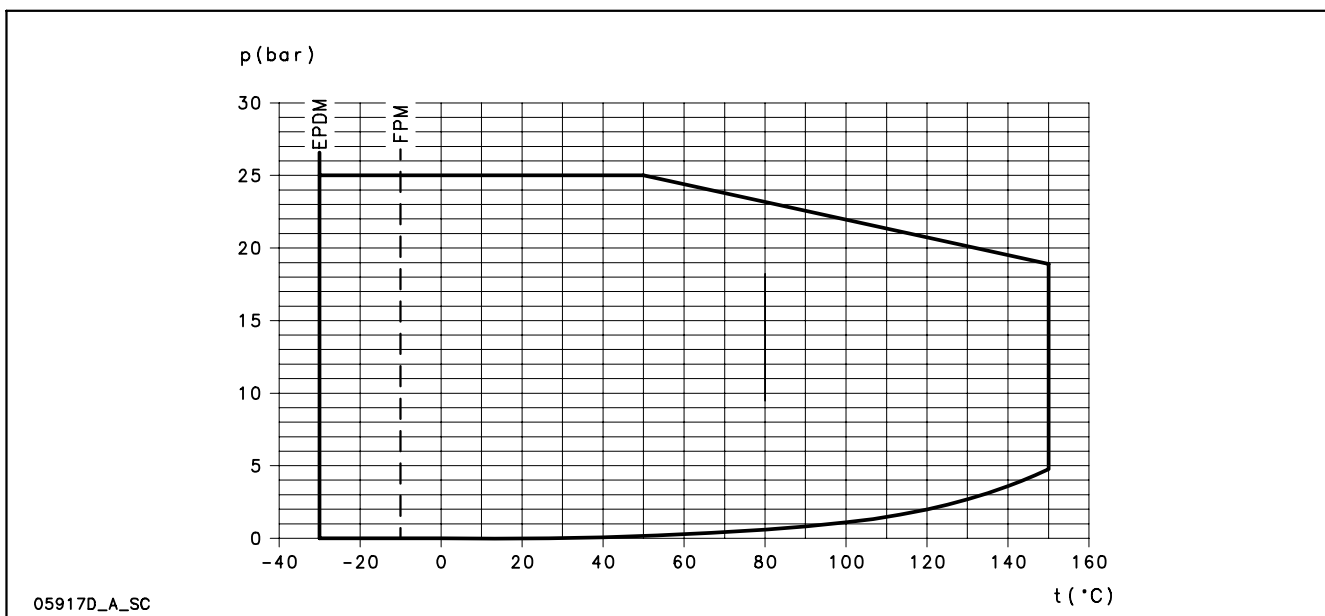

**e-SV™ SERIES - HIGH TEMPERATURE (150°C)
DIMENSIONS AT 50/60 Hz**

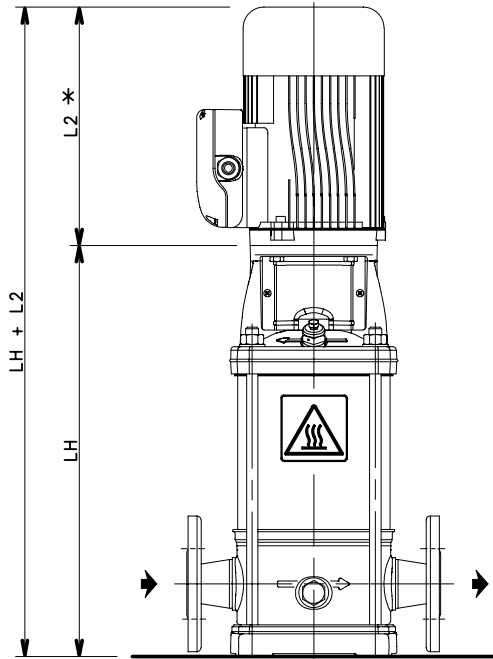

PUMP TYPE	DIMENSIONS (mm) LH	AVAILABLE STAGES		FLANGES PN
		50Hz	60Hz	
1SV-H	*L1+20	02 ÷ 37	02 ÷ 26	25
3SV-H	*L1+20	02 ÷ 31	02 ÷ 21	25
5SV-H	*L1+25	02 ÷ 30	02 ÷ 21	25
10SV-H	*L1=LH	01 ÷ 20	01 ÷ 13	25
15SV-H	*L1=LH	01 ÷ 15	01 ÷ 11	25
22SV-H	*L1=LH	01 ÷ 14	01 ÷ 10	25

*L1,*L2 = Standard product dimension, see e-SV catalogue.

1-22sv-h-en_a_td

1, 3, 5, 10, 15, 22SV SERIES

05966_A_DD

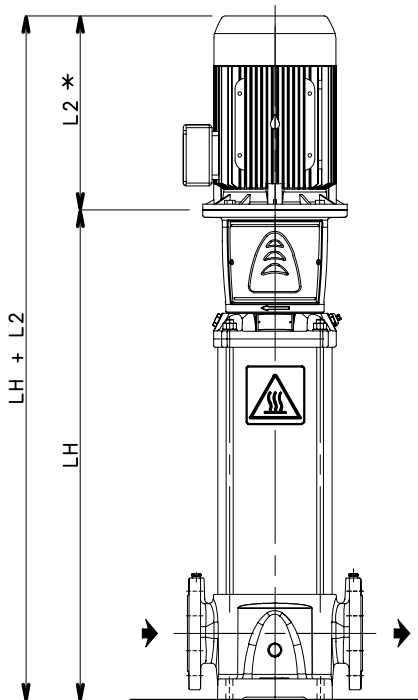

PUMP TYPE	DIMENSIONS (mm) LH	AVAILABLE STAGES		FLANGES PN
		50Hz	60Hz	
33SV-H	*L1=LH	1/1A ÷ 9	1/1A ÷ 6	25
46SV-H	*L1=LH	1/1A ÷ 9	1/1A ÷ 6	25
66SV-H	*L1=LH	1/1A ÷ 7	1/1A ÷ 5	25
92SV-H	*L1=LH	1/1A ÷ 7/2A	1/1A ÷ 4/2A	25
125SV-H	*L1=LH	1 ÷ 8/2A	1 ÷ 5/5A	25

*L1,*L2 = Standard product dimension, see e-SV catalogue.

33-125sv-h-en_a_td

33, 46, 66, 92, 125SV SERIES

HIGH TEMPERATURE

**HIGH
TEMPERATURE**

**“BOILER”
180°C
(50/60 Hz)**

**HIGH
TEMPERATURE**

e-SV™ SERIES - "BOILER" (180°C) 50/60 Hz

Background and context

In applications where industrial boilers are used, pumps often have to deal with liquids at high temperatures. In these installations, pumps need to be specifically cooled down from excessive temperatures in the mechanical seal area, in order to ensure high performance levels. That's why Lowara has developed the e-SV™ "Boiler" 180°C. This pump has a standard mechanical seal which extends its lifetime even when pumping liquids at very high temperatures.

Benefits of e-SV™ "Boiler" 180°C

Long-term mechanical seal performance:

Thanks to the special design of its housing, the seal is protected from the stress caused by high temperatures by means of a "natural" lubrication process which is triggered by the pumped liquid itself, and a cooling system which uses the air in the room. A degasser is also installed at the top of the pump in order to automatically eliminate the air in the seal area. The temperature decreased to 100°C in the mechanical seal area, together with the balanced mechanical seal and the high quality of the elastomers of the e-SV™ "Boiler" 180°C pump, assure excellent long-term performance, even in the harshest operating conditions.

Solidity: e-SV™ "Boiler" 180°C pumps are designed to operate in any application at temperatures up to 180°C. Pump body and upper chamber in cast AISI 316, balanced mechanical seal, high quality elastomers, hard metal bush supports, double outer jacket: these are the key features of the e-SV™ "Boiler" 180°C. To select the correct pump, consult the pressure-temperature diagram.

Easy and cost effective maintenance: the mechanical seal installed in e-SV™ "Boiler" 180°C pumps is a standard balanced mechanical seal (EN12756) which makes it cheap and easy to replace.

Identification code

e-SV™ "Boiler" 180°C models are identified by the letter "B" in the standard identification code of the e-SV™ product range and are available in AISI 316.

Example: 3SV13NB015T

B = "Boiler" 180°C.



Special features / benefits

- **Special design of the final stage of the pump and of the mechanical seal chamber** for high temperature applications.
- **Pump body and upper chamber in cast AISI 316.**
- **Stainless steel PN25 degasser.**
- **Hard metal intermediate bush support** (tungsten carbide) to increase the duration and capability of operating in extreme conditions, available on all sizes.
- **Balanced impeller design** to reduce axial thrust and extend the lifetime of standard motor bearings.
- **Double outer jacket** to withstand pressures of up to 25 bar and temperatures of up to 180°C.
- **IE2/IE3 standard motors**, three-phase, 2-pole, from 0,75 kW to 55 kW with fixed bearing **to endure extreme thrusts without limiting inlet pressure.**

Special configurations

A wide range of configurations is available for e-SV™ "Boiler" 180°C pumps:

- Materials used. See the "Materials" section.
- Options for mechanical seals and rubber gaskets. See the "Mechanical seals and rubber gaskets" section.
- Motor and configuration options. See the "Motor" section.

**e-SV™ SERIES - "BOILER" (180°C)
50/60 Hz**

Technical specifications - Design

- 1: Balanced mechanical seal in order to withstand high pressures and temperatures.
- 2: Special upper chamber design with recirculation of the air in the room which lowers the temperature of the mechanical seal.
- 3: Degasser to eliminate the air in the mechanical seal area.
- 4: Double outer jacket design to withstand high pressures.

Operating characteristics

For the hydraulic performances, please refer to the standard catalogue of e-SV™.

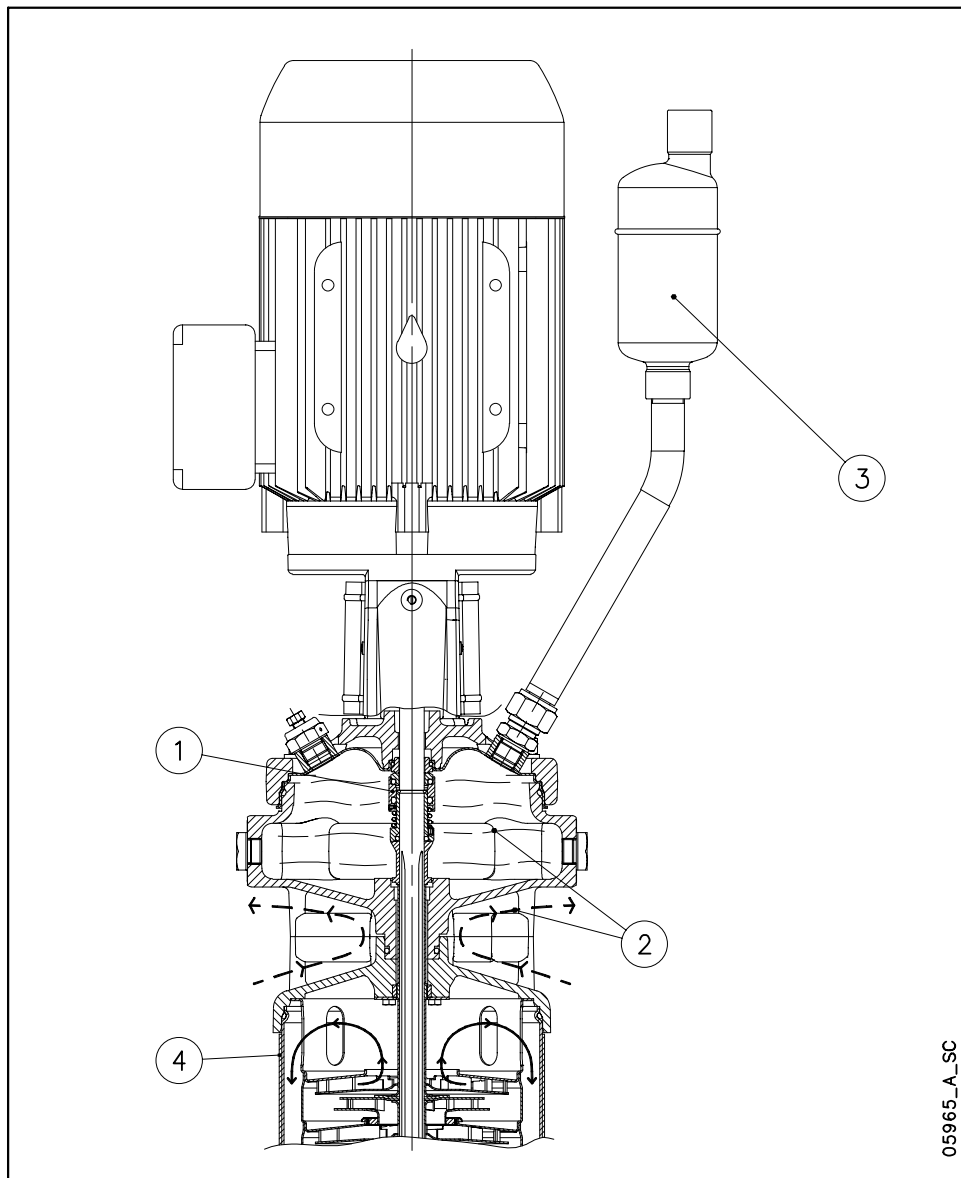

→ Route of pumped liquid.

**HIGH
TEMPERATURE**

**e-SV™ SERIES - "BOILER" (180°C) 50/60 Hz
ELECTRIC PUMP CROSS SECTION AND MAIN COMPONENTS**

HIGH TEMPERATURE

05962_A_DS

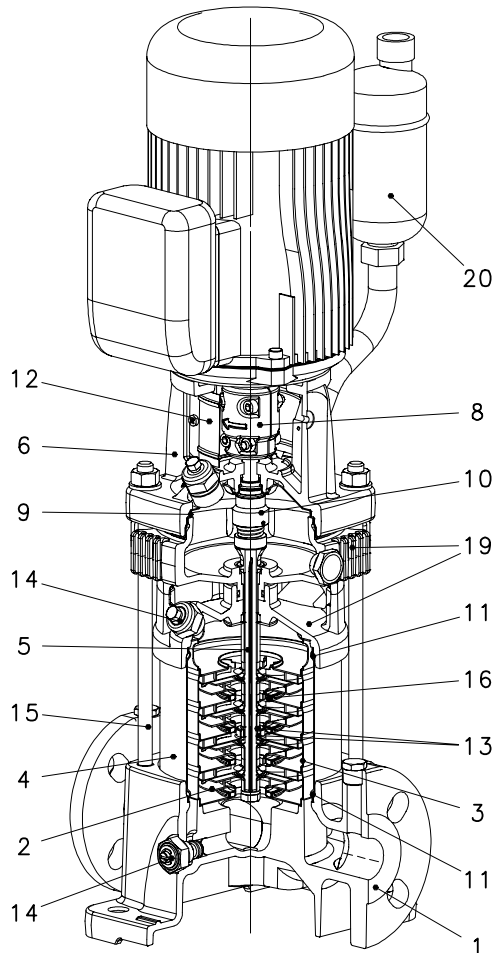

**1, 3, 5SV SERIES
10, 15, 22SV SERIES ≤ 4 kW**

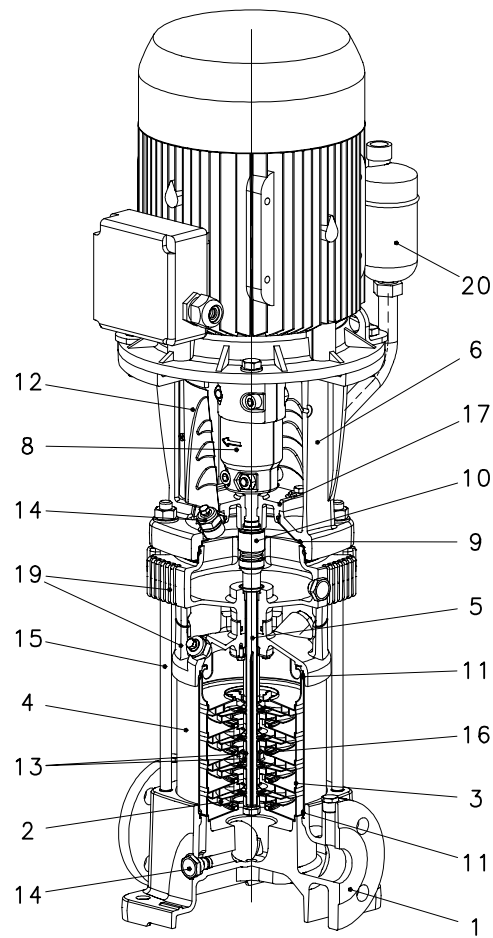

10, 15, 22SV SERIES ≥ 5,5 kW

B VERSIONS

REF. N.	NAME	MATERIAL	REFERENCE STANDARDS	
			EUROPE	USA
1	Pump body	Stainless steel	EN 10213-4-GX5CrNiMo19-11-2 (1.4408)	AISI 316
2	Impeller	Stainless steel	EN 10088-1-X2CrNiMo17-12-2 (1.4404)	AISI 316L
3	Diffuser	Stainless steel	EN 10088-1-X2CrNiMo17-12-2 (1.4404)	AISI 316L
4	Outer sleeve	Stainless steel	EN 10088-1-X2CrNiMo17-12-2 (1.4404)	AISI 316L
5	Shaft	Stainless steel	EN 10088-1-X5CrNiMo17-12-2 (1.4401)	AISI 316
6	Adapter	Cast iron	EN 1561-GJL-250 (JL1040)	ASTM Class 35
8	Coupling	Aluminium	EN 1706-AC-AISI11Cu2 (Fe) (AC46100)	-
9	Seal plate	Stainless steel	EN 10088-1-X2CrNiMo17-12-2 (1.4404)	AISI 316L
10	Mechanical seal	Silicon carbide / Carbon / EPDM		
11	Elastomers	EPDM		
12	Coupling protection	Stainless steel	EN 10088-1-X5CrNi18-10 (1.4301)	AISI 304
13	Shaft sleeve and bushing	Tungsten carbide		
14	Fill / drain plugs	Stainless steel	EN 10088-1-X5CrNiMo17-12-2 (1.4401)	AISI 316
15	Tie rods	Stainless steel	EN 10088-1-X17CrNi16-2 (1.4057)	AISI 431
16	Wear ring	Technopolymer PPS		
17	Seal housing	Stainless steel	EN 10213-4-GX5CrNiMo19-11-2 (1.4408)	AISI 316
19	Upper seal chamber	Stainless steel	EN 10213-4-GX5CrNiMo19-11-2 (1.4408)	AISI 316
20	Air vent	Stainless steel	EN 10088-1-X2CrNi19-11 (1.4306)	AISI 304L

1-22sv-b-en_a_tm

e-SV™ SERIES - "BOILER" (180°C) 50/60 Hz ELECTRIC PUMP CROSS SECTION AND MAIN COMPONENTS

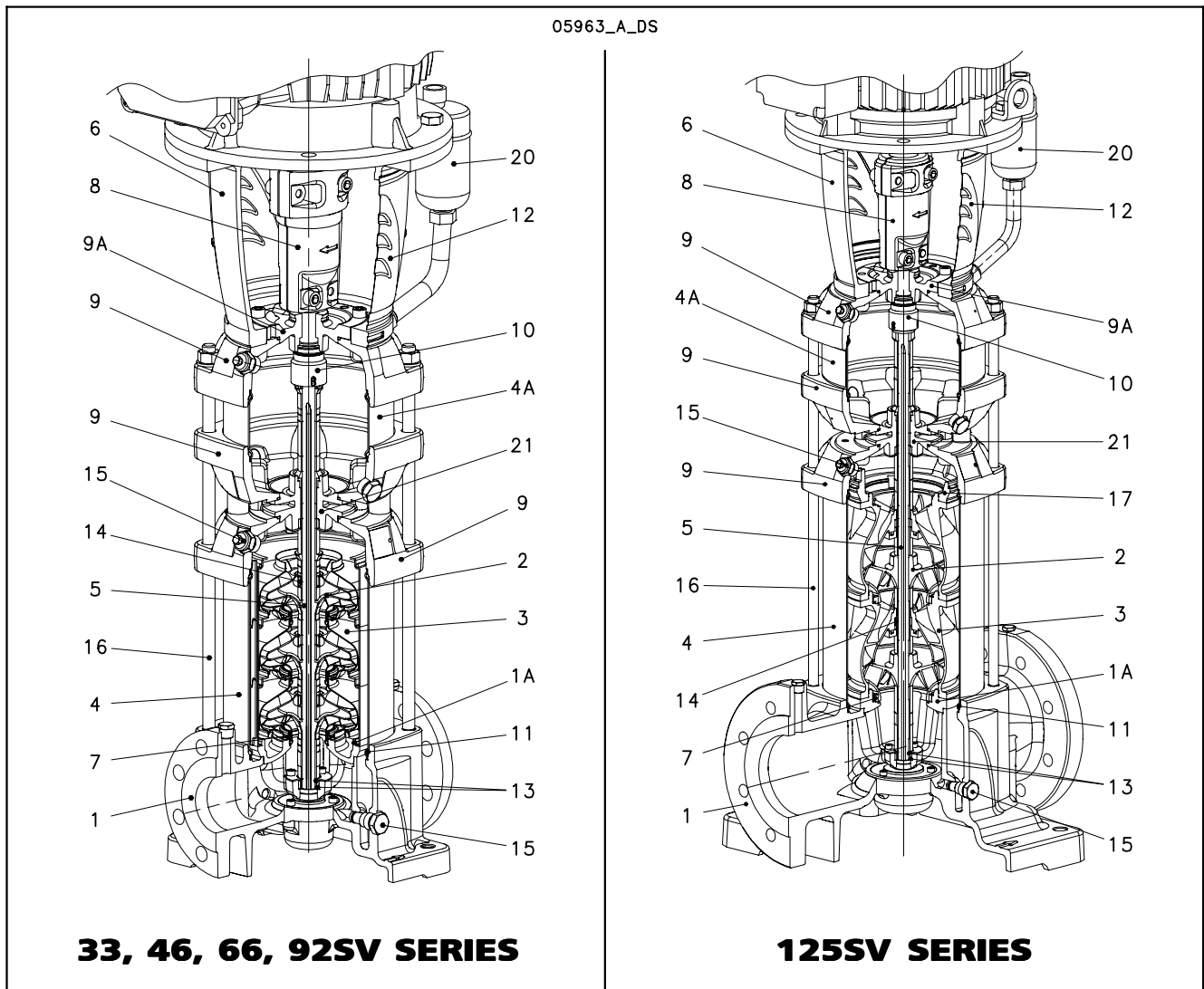

HIGH TEMPERATURE

B VERSIONS

REF. N.	NAME	MATERIAL	REFERENCE STANDARDS	
			EUROPE	USA
1	Pump body	Stainless steel	EN 10213-4-GX5CrNiMo19-11-2 (1.4408)	AISI 316
1A	Lower support	Stainless steel	EN 10213-4-GX5CrNiMo19-11-2 (1.4408)	AISI 316
2-3	Impeller, Diffuser 33SV-92SV	Stainless steel	EN 10088-1-X2CrNiMo17-12-2 (1.4404)	AISI 316L
2-3	Impeller, Diffuser 125SV	Stainless steel	EN 10213-4-GX5CrNiMo19-11-2 (1.4408)	AISI 316
4-4A	Outer sleeve	Stainless steel	EN 10088-1-X2CrNiMo17-12-2 (1.4404)	AISI 316L
5	Shaft	Duplex stainless steel	EN 10088-1-X2CrNiMoN22-5-3 (1.4462)	UNS S 31803
6	Adapter (up to 45kW)	Cast iron	EN 1561-GJL-200 (JL1030)	ASTM Class 25
	Adapter (for higher powers)	Cast iron	EN 1563-GJS-500-7 (JS1050)	ASTM A 536 80-55-06
7	Wear ring	Technopolymer PPS		
8	Coupling (up to 45kW)	Cast iron	EN 1561-GJL-200 (JL1030)	ASTM Class 25
	Coupling (for higher powers)	Cast iron	EN 1563-GJS-500-7 (JS1050)	ASTM A 536 80-55-06
9-9A	Upper head, Seal housing	Stainless steel	EN 10213-4-GX5CrNiMo19-11-2 (1.4408)	AISI 316
10	Mechanical seal	Silicon carbide / Carbon / EPDM		
11	Elastomers	EPDM		
12	Coupling protection	Stainless steel	EN 10088-1-X5CrNi18-10 (1.4301)	AISI 304
13	Shaft sleeve and bushing	Tungsten carbide		
14	Bushing for diffuser	Carbon		
15	Fill / drain / air plugs	Stainless steel	EN 10088-1-X5CrNiMo17-12-2 (1.4401)	AISI 316
16	Tie rods	Stainless steel	EN 10088-1-X17CrNi16-2 (1.4057)	AISI 431
17	Adapter ring	Stainless steel	EN 10213-4-GX5CrNiMo19-11-2 (1.4408)	AISI 316
20	Air vent	Stainless steel	EN 10088-1-X2CrNi19-11 (1.4306)	AISI 304L
21	Separating flange	Stainless steel	EN 10213-4-GX5CrNiMo19-11-2 (1.4408)	AISI 316

**e-SV™ SERIES - "BOILER" (180°C) 50/60 Hz
BALANCED MECHANICAL SEALS, ACCORDING TO EN 12756**

HIGH TEMPERATURE

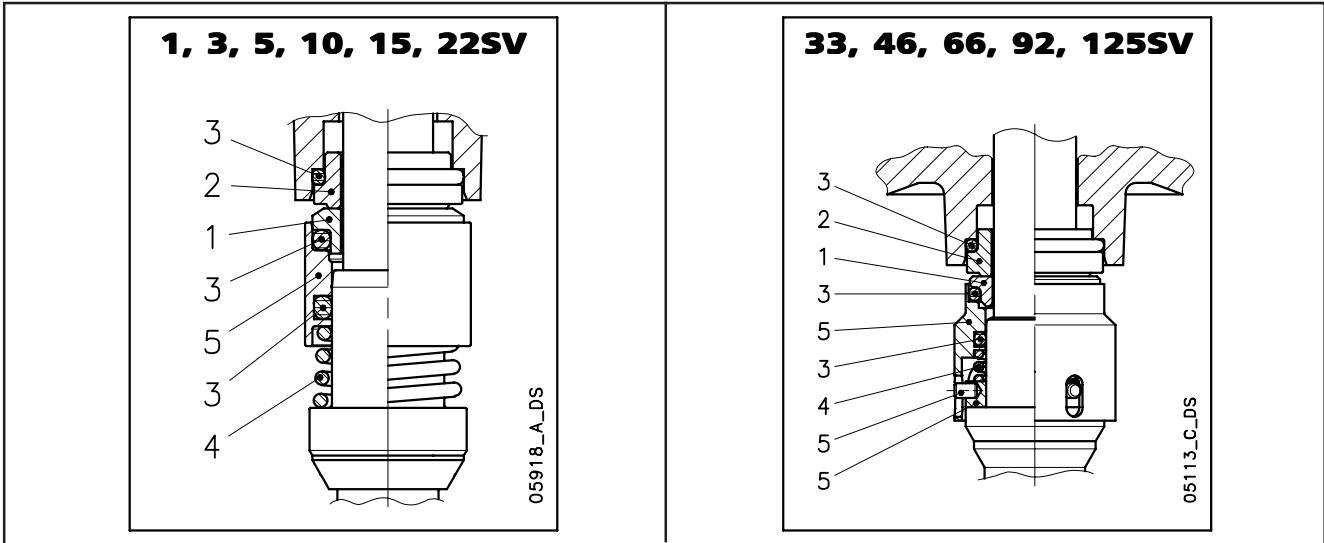

LIST OF MATERIALS

POSITION 1 - 2	POSITION 3	POSITION 4 - 5
Q ₁ : Silicon Carbide	E : EPDM	G : AISI 316
A : Carbon metal-impregnated	V : FPM	

TYPE OF SEAL

sv-at_ten-mec-en_a_tm

TYPE	POSITION					TEMPERATURE (°C)
	1 ROTATING PART	2 STATIONARY PART	3 ELASTOMERS	4 SPRINGS	5 OTHER COMPONENTS	
MECHANICAL SEAL FOR USE WITH WATER						
Q ₁ A E G G	Q ₁	A	E	G	G	-30 +150
OTHER TYPES OF AVAILABLE MECHANICAL SEAL						
Q ₁ A V G G	Q ₁	A	V	G	G	-10 +150
*Q ₁ Q ₁ V G G	Q ₁	Q ₁	V	G	G	-10 +150

* Versions with anti-rotation lock pin of the fixed part.

sv-at_tipi-ten-mec-en_a_tc

**PRESSURE/TEMPERATURE APPLICATION LIMITS FOR COMPLETE PUMP
(APPLICABLE WITH ANY OF THE SEALS LISTED ABOVE)**

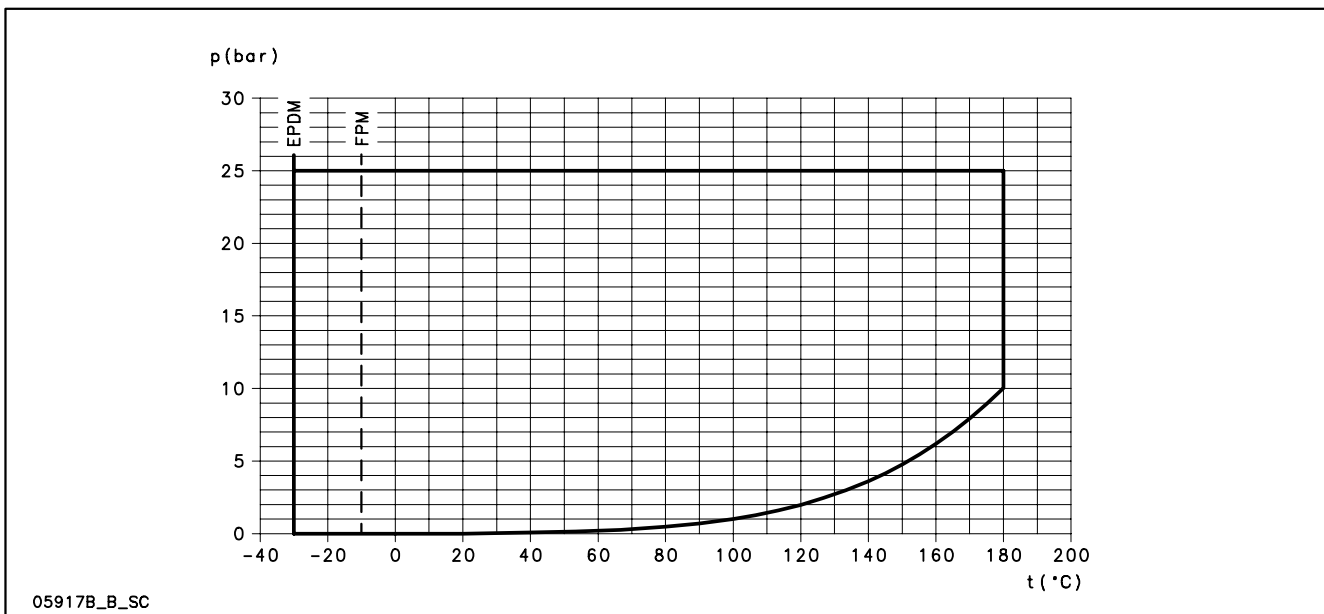

e-SV™ SERIES - "BOILER" (180°C) DIMENSIONS AT 50/60 Hz

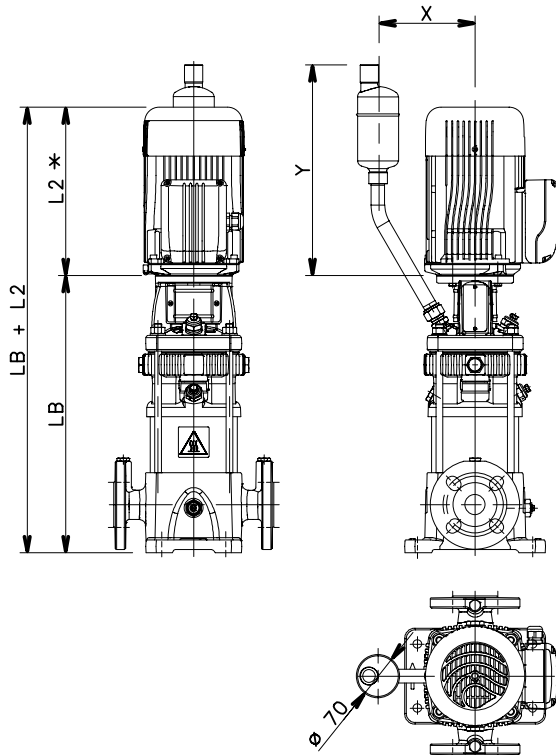

1, 3, 5, 10, 15, 22SV SERIES

PUMP TYPE	DIMENSIONS (mm) LB	AVAILABLE STAGES		FLANGES PN
		50Hz	60Hz	
1SV-B	*L1+105	02 ÷ 37	02 ÷ 26	25
3SV-B	*L1+105	02 ÷ 31	02 ÷ 21	25
5SV-B	*L1+105	02 ÷ 30	02 ÷ 21	25
10SV-B	*L1+147	01 ÷ 20	01 ÷ 13	25
15SV-B	*L1+153	01 ÷ 15	01 ÷ 11	25
22SV-B	*L1+153	01 ÷ 14	01 ÷ 10	25

*L1,*L2 = Standard product dimension, see e-SV catalogue.

PUMP TYPE	MOTOR TYPE	DIMENSIONS mm	
		X	Y
1SV ÷ 5SV	from 0,37 ÷ 0,55 kW	150	336
1SV ÷ 5SV	from 0,75 ÷ 1,1 kW		326
1SV ÷ 5SV	from 1,5 ÷ 2,2 kW		316
1SV ÷ 5SV	from 3 ÷ 4 kW		306
5SV	from 5,5 kW	185	242
10SV ÷ 22SV	from 0,75 ÷ 1,1 kW	164	304
10SV ÷ 22SV	from 1,5 ÷ 2,2 kW		294
10SV ÷ 22SV	from 3 ÷ 4 kW		284
10SV ÷ 22SV	from 5,5 ÷ 7,5 kW	210	250
10SV ÷ 22SV	from 11 ÷ 18,5 kW		220

1-22sv-b-en_a_td

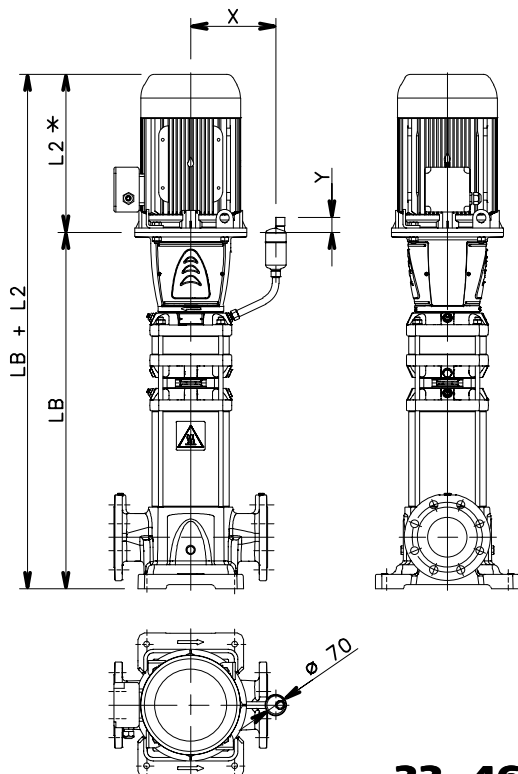

33, 46, 66, 92, 125SV SERIES

PUMP TYPE	DIMENSIONS (mm) LB	AVAILABLE STAGES		FLANGES PN
		50Hz	60Hz	
33SV-B	*L1+225	1/1A ÷ 9	1/1A ÷ 6	25
46SV-B	*L1+225	1/1A ÷ 9	1/1A ÷ 6	25
66SV-B	*L1+235	1/1A ÷ 7	1/1A ÷ 5	25
92SV-B	*L1+235	1/1A ÷ 7/2A	1/1A ÷ 4/2A	25
125SV-B	*L1+235	1 ÷ 8/2A	1 ÷ 5/5A	25

*L1,*L2 = Standard product dimension, see e-SV catalogue.

PUMP TYPE	MOTOR TYPE	DIMENSIONS mm	
		X	Y
33SV ÷ 46SV	from 2,2 ÷ 4 kW	265	108
66SV	from 2,2 ÷ 4 kW		119
33SV ÷ 46SV	from 5,5 ÷ 7,5 kW	265	88
66SV ÷ 125SV	from 5,5 ÷ 7,5 kW		99
33SV ÷ 46SV	from 11 ÷ 45 kW	265	53
66SV ÷ 125SV	from 11 ÷ 45 kW		64
125SV	from 55 kW	315	58

33-125sv-b-en_b_td

05968_A_DD

HIGH TEMPERATURE

**e-SVH
WITH HYDROVAR®
(50 Hz)**

**e-SVH
HYDROVAR®**

e-SV™ SERIES - VERSION WITH HYDROVAR® 50 Hz

Background and context

In all areas of application, such as building services, industry, agriculture and air-handling, the demand for intelligent pumping systems is constantly growing. There are many advantages: reduced cost for pump life cycle, lower environmental impact, longer lifetime of pipes and unions. That's why Lowara has developed the e-SVH: an intelligent pumping system which assures high level performance with energy consumption tailored to demand.

Benefits of e-SVH with Hydrovar®

Saving: e-SVH transform e-SV™ pumps into variable speed intelligent pumping systems. Thanks to the Hydrovar® system, the speed of each pump varies so as to maintain a constant flow or pressure. The pump only receives the energy required, thus allowing considerable savings, especially for those systems in which demands varies during the day.

Easy installation and space-saving: e-SVH save time and space during installation. Installed directly on the motor, which cools it down, the e-SVH do not require a control panel or an external control or safety device. Thanks to the Hydrovar® technology, there is no need for large diaphragm tanks to complete installation.

Standard motors: e-SVH are fitted with three-phase standard TEFC motors with insulation class F and power outputs of up to 22 kW. Wall-mounted versions with a maximum power output of 45 kW are also available.

Identification code

e-SVH models are identified by the letter "H" in the standard identification code of the e-SV™ product range.

Example: 3SVH13F015T

H = with integrated Hydrovar®.



Special features / benefits

- **There is no need for additional pressure sensors:** e-SVH are fitted with a pressure transmitter or differential pressure transmitters, depending on the application.
- **There is no need for special pumps or motors.**
- **There is no need for bypass or safety systems:** With Hydrovar® the pump immediately switches off when demand drops to zero or when it exceeds maximum pump capacity. This makes it unnecessary to install additional safety devices.
- **Anti-condensation device:** All units are fitted with anti-condensation devices which switch on when the pump is in standby in order to prevent condensation forming in the unit.
- **i-Alert device** to reduce the costs for each life cycle, thus increasing the mean time between failures (MTBF).

Special configurations

e-SVH have the same range of configurations as the standard e-SV™ series.

- Materials used. See the "Materials" section.
- Options for mechanical seals and rubber gaskets. See the "Mechanical seals and rubber gaskets" section.
- Motor and configuration options. See the "Motor" section.

OPERATING PRINCIPLE

The basic function of the Hydrovar® device is to control the pump to meet the system demands.

HYDROVAR® performs these functions by:

- 1) Measuring the system pressure or flow via a transmitter mounted on the pump's delivery side.
- 2) Calculating the motor speed to maintain the correct flow or pressure.
- 3) Sending out a signal to the pump to start the motor, increase speed, decrease speed or stop.
- 4) In the case of multiple pump installations, Hydrovar® will automatically provide for the cyclic changeover of the pump's starting sequence.

In addition to these basic functions, Hydrovar® can do things only by the most advanced computerised control systems, such as:

- Stop the pump(s) at zero demand.
- Stop the pump(s) in case of water failure on the suction side (protection against dry running).
- Stop the pump if the required delivery exceeds the pump's capacity (protection against cavitation caused by excessive demand), or automatically switch on the next pump in a multiple series.
- Protect the pump and motor from overvoltage, undervoltage, overload and earth fault.
- Vary the pump speed acceleration and deceleration time.
- Compensate for increased flow resistance at high flow rates.
- Conduct automatic test starts at set intervals.
- Monitor the converter and motor operating hours.
- Display all functions on an LCD in different languages (Italian, English, French, German, Spanish, Portuguese, Dutch).
- Send a signal to a remote control system which is proportional to the pressure and frequency.
- Communicate with another Hydrovar® or control system via an RS 485 interface.

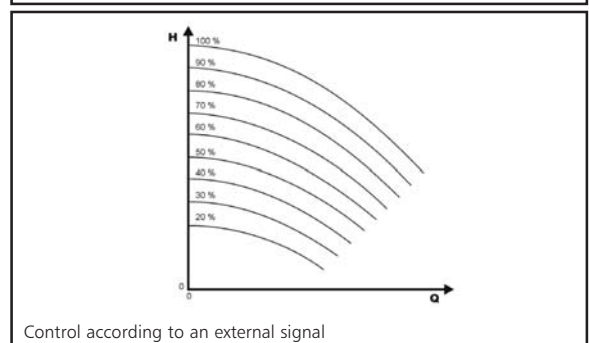
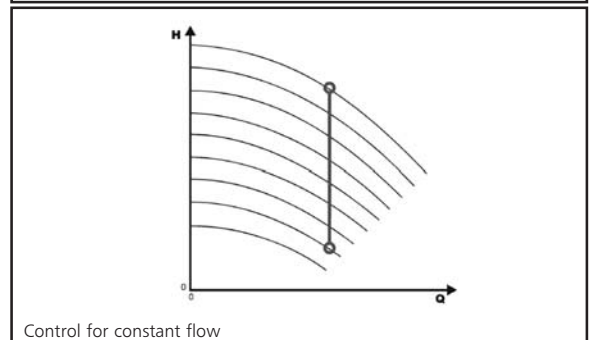
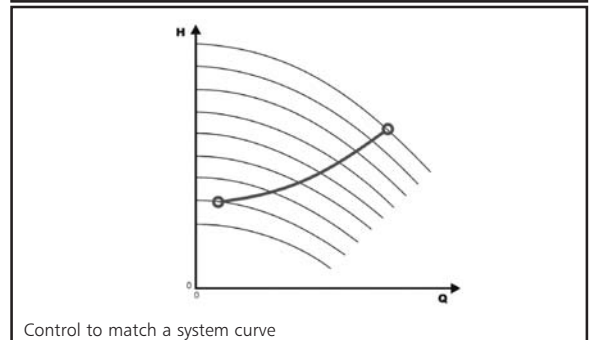
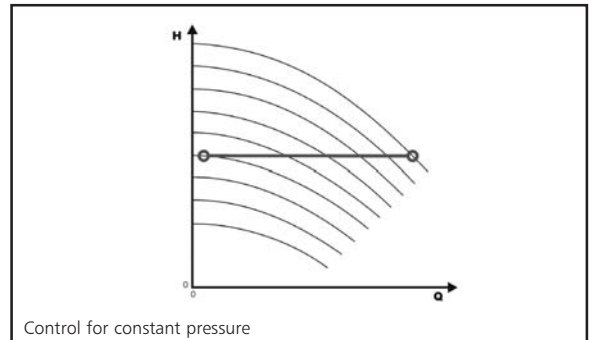

TYPICAL EXAMPLE OF ENERGY SAVINGS

System: 22SV07F75T vertical multistage electric pump with 7,5 kW motor equipped with Hydrovar®, 70 m head. 19 hour/day operation.

Application: maintaining a constant pressure as the flow rate varies.

FLOW m ³ /h	ABSORBED POWER		POWER SAVED kW	OPERATING TIME (hours)	TOTAL ENERGY SAVINGS kWh
	CONSTANT SPEED PUMP kW	VARIABLE SPEED PUMP kW			
24	7,4	7,4	0,0	876	-
21	6,9	6,1	0,8	876	701
18	6,5	5,0	1,5	1752	2.628
14	5,6	3,8	1,8	1752	3.154
10	5,1	2,8	2,3	1752	4.030
YEARLY ENERGY SAVINGS (kWh)					10.512

1, 3, 5, 10, 15, 22SVH SERIES HYDRAULIC PERFORMANCE TABLE AT 50 Hz, 2 POLES

PUMP TYPE	RATED POWER		Q = DELIVERY													
			l/min 0	12	20	25	30	35	40	45	50	60	73	100	120	141
	kW	HP	m ³ /h 0	0,7	1,2	1,5	1,8	2,1	2,4	2,7	3,0	3,6	4,4	6,0	7,2	8,5
H = TOTAL HEAD IN METRES OF COLUMN OF WATER																
1SVH15	0,75	1	90,9	90,5	85,6	79,3	70,1	58,1	43,1							
1SVH22	1,1	1,5	134,6	134,1	127,4	118,1	104,4	86,1	63,5							
1SVH30	1,5	2	181,7	181,3	172,6	160,1	141,2	115,7	83,9							
1SVH37	2,2	3	225,9	224,9	216,1	201,9	179,3	148,1	108,7							
3SVH08	0,75	1	60,0		59,1	58,2	57,0	55,4	53,4	51,0	48,1	40,7	27,5			
3SVH12	1,1	1,5	89,6		87,8	86,4	84,5	82,1	79,1	75,5	71,1	59,9	40,1			
3SVH16	1,5	2	119,9		117,8	116,1	113,6	110,5	106,5	101,6	95,8	80,9	54,2			
3SVH21	2,2	3	159,3		156,9	154,6	151,4	147,3	142,1	135,7	128,0	108,5	73,6			
3SVH25	2,2	3	188,5		186,1	183,3	179,3	174,1	167,6	159,7	150,3	126,6	84,8			
3SVH29	3	4	219,3		216,0	212,8	208,3	202,6	195,3	186,4	175,7	148,6	100,2			
3SVH33	3	4	248,5		245,3	241,5	236,2	229,3	220,7	210,2	197,7	166,3	111,2			
5SVH05	0,75	1	38,0						36,4	36,0	35,5	34,5	32,9	28,2	23,5	17,1
5SVH08	1,1	1,5	60,1						57,6	57,0	56,2	54,6	51,8	44,1	36,2	25,8
5SVH11	1,5	2	82,8						79,3	78,4	77,5	75,2	71,4	60,7	49,9	35,6
5SVH14	2,2	3	105,7						102,0	100,9	99,6	96,6	91,7	77,8	64,0	46,3
5SVH16	2,2	3	120,5						115,9	114,6	113,1	109,6	103,9	87,8	72,1	51,8
5SVH21	3	4	157,9						152,0	150,3	148,3	143,6	136,1	114,9	94,2	67,6
5SVH28	4	5,5	211,5						204,2	201,9	199,4	193,3	183,4	155,5	128,0	92,7
5SVH33	5,5	7,5	249,2						241,0	238,4	235,5	228,4	216,9	184,2	151,9	110,3

Performances in compliance with ISO 9906 - Annex A.

1-5svh-2p50-en_b_th

PUMP TYPE	RATED POWER		Q = DELIVERY													
			l/min 0	83,34	100	133	170	183,34	233	270	330	350	400	430	460	483,33
	kW	HP	m ³ /h 0	5,0	6,0	8,0	10,2	11,0	14,0	16,2	19,8	21,0	24,0	25,8	27,6	29,0
H = TOTAL HEAD IN METRES OF COLUMN OF WATER																
10SVH04	1,5	2	47,7	44,2	43,0	39,9	34,8	32,6	21,7							
10SVH06	2,2	3	71,8	66,8	65,0	60,4	53,1	49,8	33,9							
10SVH08	3	4	95,3	88,9	86,5	80,1	70,2	65,7	44,5							
10SVH11	4	5,5	129,6	121,3	118,1	109,6	96,3	90,3	62,1							
10SVH15	5,5	7,5	179,5	167,9	163,4	151,6	132,8	124,3	83,9							
10SVH20	7,5	10	240,6	226,0	220,3	205,0	180,2	168,9	114,3							
10SVH21	11	15	253,6	241,0	235,5	220,2	195,0	183,5	127,5							
15SVH02	2,2	3	28,7			26,7	25,9	25,5	23,9	22,4	18,9	17,4	13,1			
15SVH03	3	4	43,3			40,4	39,1	38,6	36,2	33,8	28,7	26,5	20,1			
15SVH05	4	5,5	72,7			67,8	65,8	65,0	61,0	57,1	48,7	45,2	34,9			
15SVH07	5,5	7,5	101,9			94,5	91,9	90,8	85,7	80,6	69,4	64,7	50,5			
15SVH09	7,5	10	131,9			124,4	121,0	119,6	112,8	106,1	91,5	85,5	67,4			
15SVH13	11	15	191,3			179,2	174,5	172,5	163,1	153,7	133,1	124,5	98,6			
15SVH17	15	20	251,6			237,3	231,4	228,9	216,9	205,0	178,4	167,3	133,6			
22SVH01	1,1	1,5	14,7					13,5	12,7	12,0	10,4	9,7	7,7	6,3	4,7	3,4
22SVH03	3	4	45,4					42,2	40,4	38,5	34,5	32,8	27,8	24,2	20,2	16,6
22SVH04	4	5,5	60,9					56,8	54,4	51,9	46,6	44,4	37,9	33,1	27,7	23,0
22SVH05	5,5	7,5	76,0					70,9	67,9	64,9	58,3	55,6	47,4	41,4	34,7	28,8
22SVH07	7,5	10	108,5					103,1	99,4	95,7	87,2	83,7	73,1	65,3	56,5	48,8
22SVH10	11	15	155,4					148,2	143,1	137,8	125,9	120,9	105,8	94,8	82,3	71,3
22SVH14	15	20	216,6					207,7	200,9	193,7	177,4	170,4	149,4	133,9	116,1	100,6
22SVH17	18,5	25	263,5					252,8	244,7	236,0	216,2	207,8	182,3	163,6	142,0	123,2

Performances in compliance with ISO 9906 - Annex A.

10-22svh-2p50-en_b_th

33, 46, 66, 92SVH SERIES

HYDRAULIC PERFORMANCE TABLE AT 50 Hz, 2 POLES

PUMP TYPE	RATED POWER		Q = DELIVERY											
			l/min 0	250	300	367	417	500	583	667	750	900	1000	
	kW	HP	m ³ /h 0	15	18	22	25	30	35	40	45	54	60	
H = TOTAL HEAD METRES COLUMN OF WATER														
33SVH1	3	4	23,8	21,7	21,2	20	20	17,8	15,5	12,7				
33SVH2	5,5	7,5	47,8	45	44,1	43	41	39	35	29,9				
33SVH3	7,5	10	71,5	67,4	66,0	64	62	58	52,0	44,6				
33SVH4	11	15	95,9	91,1	90	87	85	80	73	63,1				
33SVH5	15	20	120,4	114,9	113	110	107	101	92	80,5				
33SVH6	15	20	145,6	139	137	133	129	121	110	96,1				
33SVH7	18,5	25	170,3	162,8	160	156	152	142	130	113,3				
46SVH1	4	5,5	27,2			24	23,5	22,5	21,4	19,9	18,2	14,3	10,8	
46SVH2	7,5	10	52,6			48,5	47,7	46,1	44,2	41,7	38,7	31,4	25,1	
46SVH3	11	15	80,8			74,3	73	71	68	65	60	50	40,7	
46SVH4	15	20	107,3			99,8	98	96	92	87	82	68	55,9	
46SVH6	22	30	161			149,9	148	144	139	132	124	104	86	

Performances in compliance with ISO 9906 - Annex A.

33-46svh-2p50-en_a_th

PUMP TYPE	RATED POWER		Q = DELIVERY												
			l/min 0	500	600	700	750	900	1000	1200	1300	1417	1600	1800	2000
	kW	HP	m ³ /h 0	30	36	42	45	54	60	72	78	85	96	108	120
H = TOTAL HEAD METRES COLUMN OF WATER															
66SVH1	5,5	7,5	29,2	25,8	24,8	23,8	23,3	21,8	20,7	17,9	16,1	13,5			
66SVH2	11	15	60,4	55,7	54,4	52,8	52	49,3	47,1	42	38,9	34,7			
66SVH3	18,5	25	91,4	84,7	83	81	79	75	72	64	60	53,5			
66SVH4	22	30	121,6	112,5	110	107	105	100	96	86	79	70,8			
92SVH1	7,5	10	33,5				28,7	27,2	26,2	24,3	23,3	22,2	20,2	17,6	14,3
92SVH2	15	20	67,8				58,2	55	53	49,5	47,6	45,2	41,4	36,3	29,6
92SVH3	22	30	102,2				88,2	84	81	76	73	69	63	56	46,3

Performances in compliance with ISO 9906 - Annex A.

66-92svh-2p50-en_a_th

1, 3, 5, 10, 15, 22, 33, 46, 66, 92SVH SERIES ELECTRICAL DATA TABLE AT 50 Hz

PUMP TYPE	NOMINAL POWER		SVH..M INPUT CURRENT 1X230 V	SVH..T INPUT CURRENT 3X400 V
	kW	HP	A	A
1SVH15	0,75	1	5,4	-
1SVH22	1,1	1,5	7,5	2,5
1SVH30	1,5	2	10,0	3,3
1SVH37	2,2	3	14,6	4,9
3SVH08	0,75	1	5,4	-
3SVH12	1,1	1,5	7,5	2,5
3SVH16	1,5	2	10,0	3,3
3SVH21	2,2	3	14,6	4,9
3SVH25	2,2	3	14,6	4,9
3SVH29	3	4	-	6,4
3SVH33	3	4	-	6,4
5SVH05	0,75	1	5,4	-
5SVH08	1,1	1,5	7,5	2,5
5SVH11	1,5	2	10,0	3,3
5SVH14	2,2	3	14,6	4,9
5SVH16	2,2	3	14,6	4,9
5SVH21	3	4	-	6,4
5SVH28	4	5,5	-	8,1
5SVH33	5,5	7,5	-	10,9
10SVH04	1,5	2	10,0	3,3
10SVH06	2,2	3	14,6	4,9
10SVH08	3	4	-	6,4
10SVH11	4	5,5	-	8,1
10SVH15	5,5	7,5	-	10,9
10SVH20	7,5	10	-	14,7
10SVH21	11	15	-	21,4
15SVH02	2,2	3	14,6	4,9
15SVH03	3	4	-	6,4
15SVH05	4	5,5	-	8,1
15SVH07	5,5	7,5	-	10,9
15SVH09	7,5	10	-	14,7
15SVH13	11	15	-	21,4
15SVH17	15	20	-	27,4
22SVH01	1,1	1,5	7,5	2,5
22SVH03	3	4	-	6,4
22SVH04	4	5,5	-	8,1
22SVH05	5,5	7,5	-	10,9
22SVH07	7,5	10	-	14,7
22SVH10	11	15	-	21,4
22SVH14	15	20	-	27,4
22SVH17	18,5	25	-	34,9
33SVH1	3	4	-	6,4
33SVH2	5,5	7,5	-	10,9
33SVH3	7,5	10	-	14,7
33SVH4	11	15	-	21,4
33SVH5	15	20	-	27,4
33SVH6	15	20	-	27,4
33SVH7	18,5	25	-	34,9
46SVH1	4	5,5	-	8,1
46SVH2	7,5	10	-	14,7
46SVH3	11	15	-	21,4
46SVH4	15	20	-	27,4
46SVH6	22	30	-	40,6
66SVH1	5,5	7,5	-	10,9
66SVH2	11	15	-	21,4
66SVH3	18,5	25	-	34,9
66SVH4	22	30	-	40,6
92SVH1	7,5	10	-	14,7
92SVH2	15	20	-	27,4
92SVH3	22	30	-	40,6

La corrente indicata è la corrente nominale a 50Hz, 2900rpm

1-92svh-2p50-en_b_te

1SVH SERIES
DIMENSIONS AND WEIGHTS AT 50 Hz

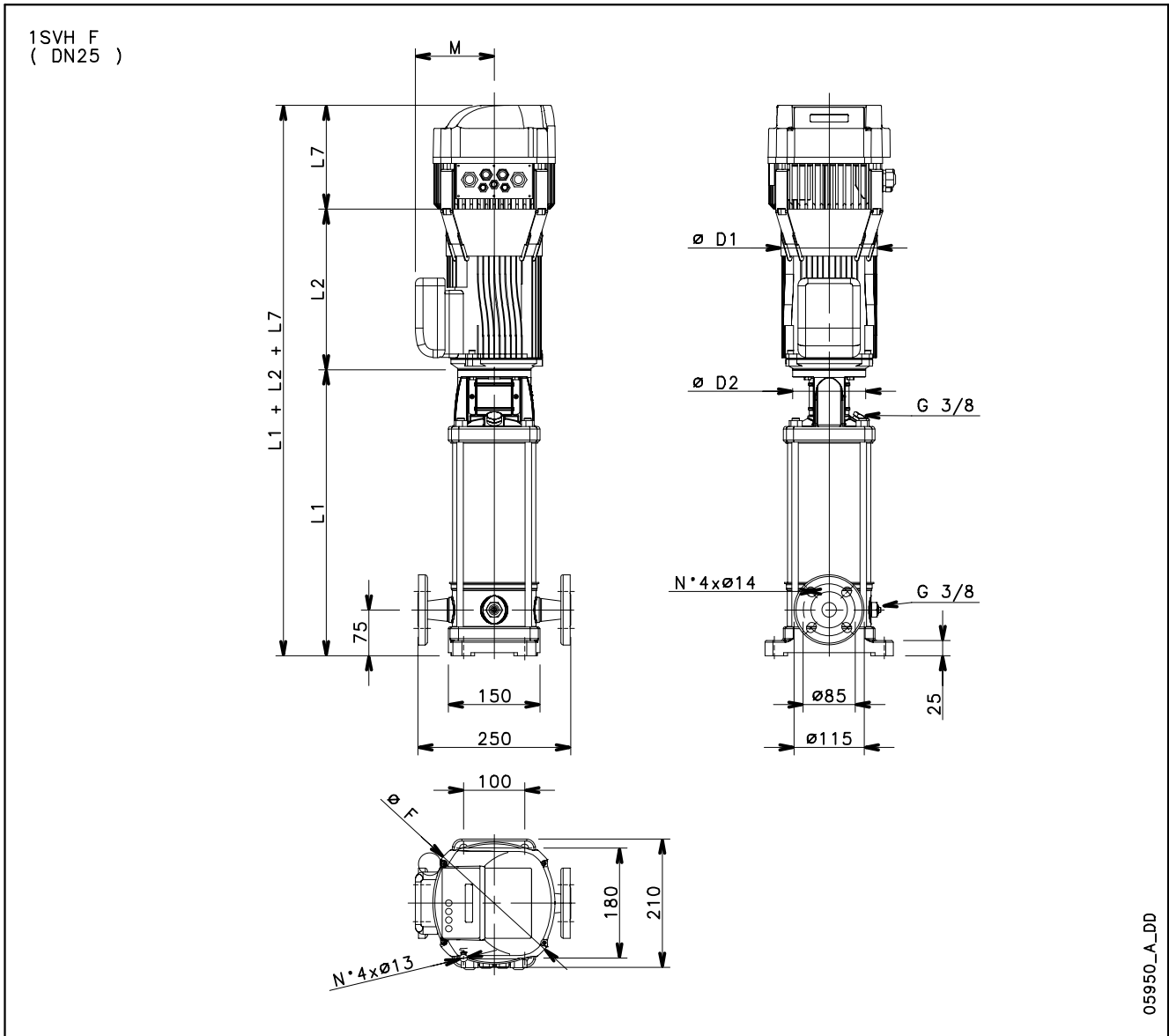

05950_A_DD

e-SVH
HYDROVAR®

PUMP TYPE	MOTOR		DIMENSIONS (mm)							WEIGHT kg	
	kW	SIZE	L1	L2 3~	L7	F	M 3~	D1 3~	D2	PUMP	ELECTRIC PUMP
1SVH15../D	0,75	80	528	263	170	225	129	155	120	13,9	23,6
1SVH22../D	1,1	80	668	263	170	225	129	155	120	16,7	28,6
1SVH30../D	1,5	90	838	263	170	225	129	155	140	20,7	34
1SVH37..	2,2	90	978	298	170	225	134	174	140	23,5	40

1svh-2p50-en_b_td

3SVH SERIES
DIMENSIONS AND WEIGHTS AT 50 Hz

e-SVH
HYDROVAR®

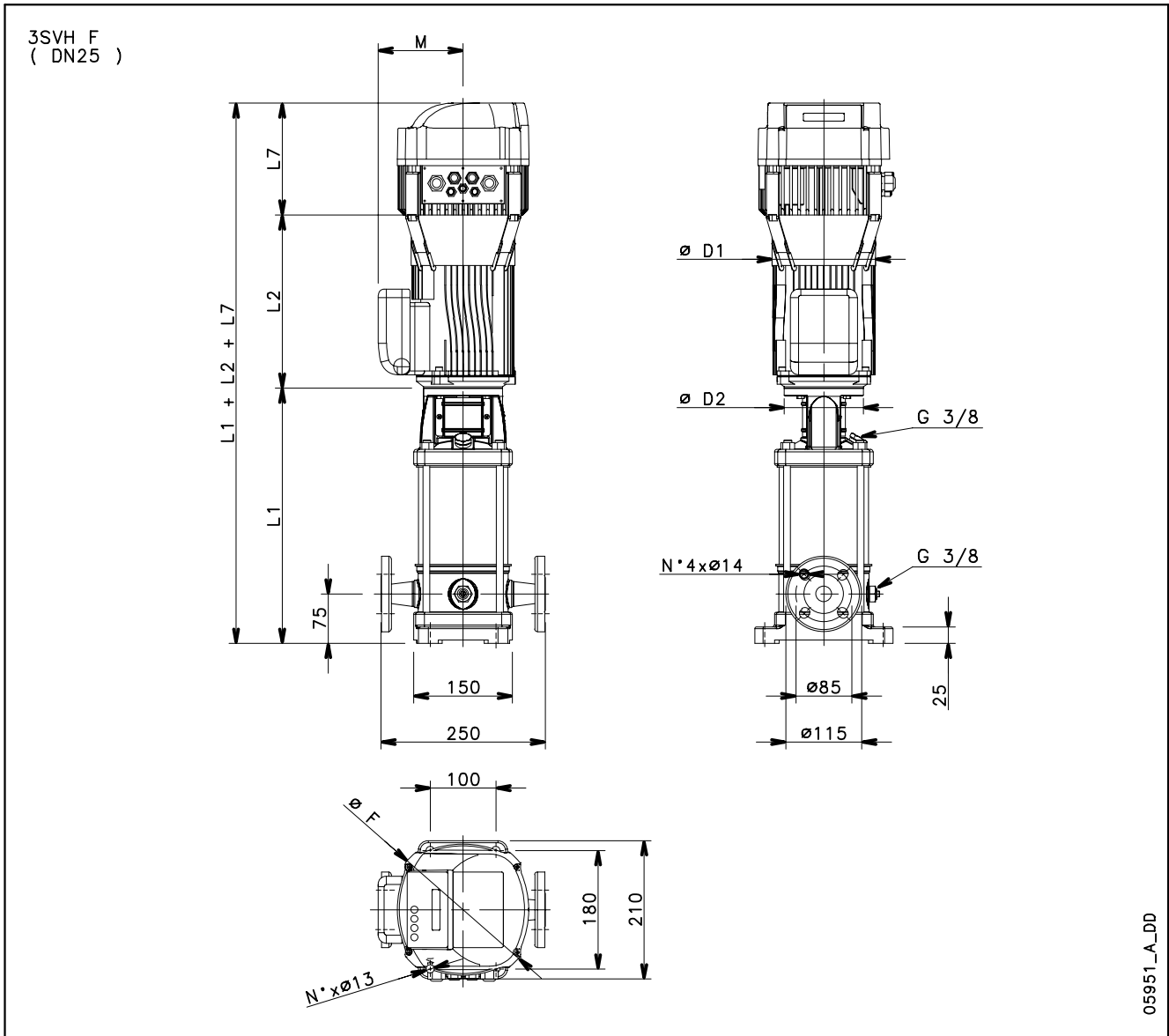

05951_A_DD

PUMP TYPE	MOTOR		DIMENSIONS (mm)							WEIGHT kg	
	kW	SIZE	L1	L2 3 ~	L7	F	M 3 ~	D1 3 ~	D2	PUMP	ELECTRIC PUMP
3SVH08../D	0,75	80	388	263	170	225	129	155	120	11,3	20,9
3SVH12../D	1,1	80	468	263	170	225	129	155	120	13,3	24,7
3SVH16../D	1,5	90	558	263	170	225	129	155	140	15,2	28,2
3SVH21..	2,2	90	658	298	170	225	134	174	140	17,2	35,2
3SVH25..	2,2	90	738	298	170	225	134	174	140	18,9	36,8
3SVH29..	3	100	828	298	170	225	134	174	160	21,5	43,4
3SVH33..	3	100	908	298	170	225	134	174	160	23,1	45

3svh-2p50-en_b_td

5SVH SERIES
DIMENSIONS AND WEIGHTS AT 50 Hz

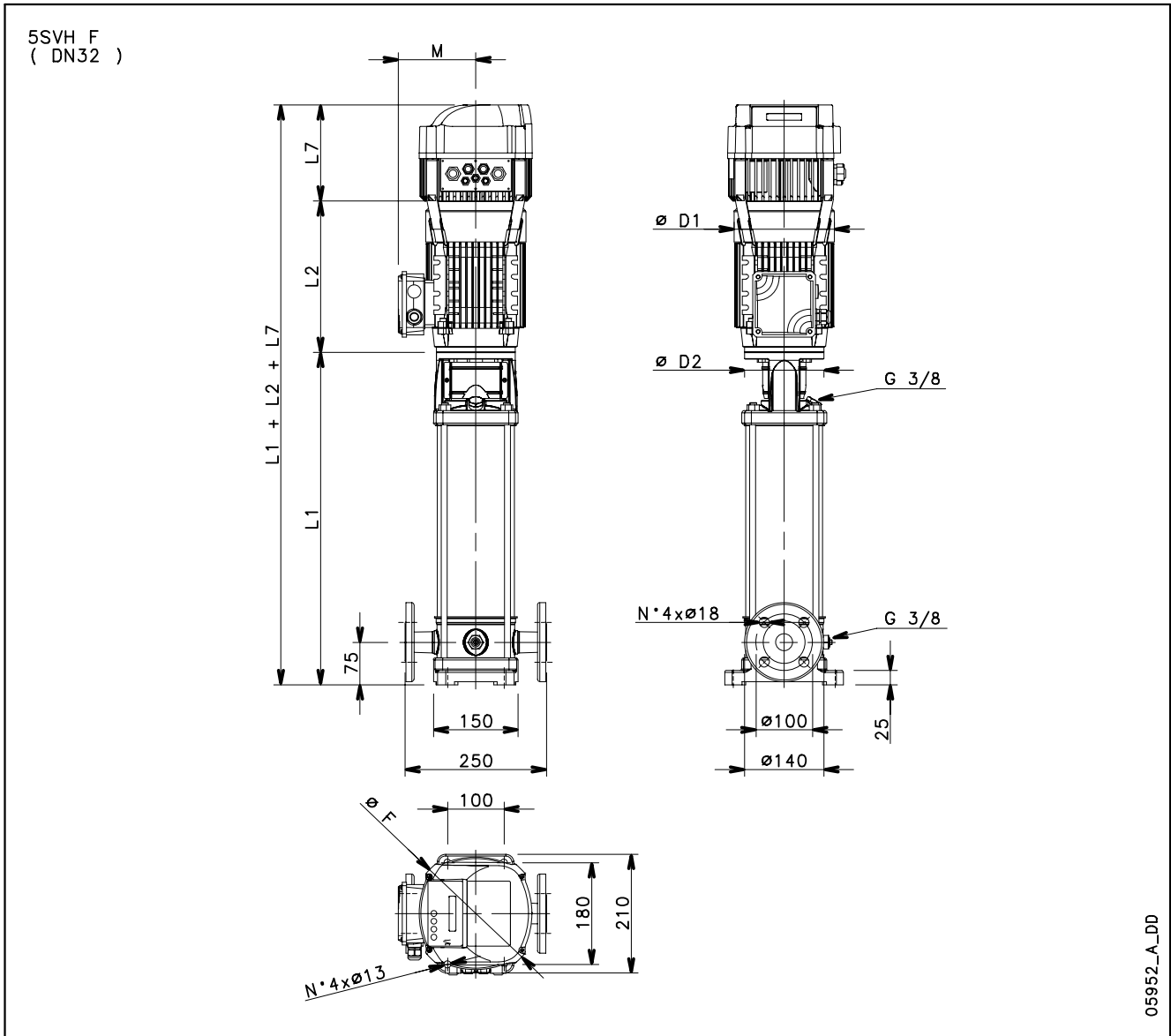

e-SVH
HYDROVAR®

PUMP TYPE	MOTOR		DIMENSIONS (mm)							WEIGHT kg	
	kW	SIZE	L1	L2 3 ~	L7	F	M 3 ~	D1 3 ~	D2	PUMP	ELECTRIC PUMP
5SVH05../D	0,75	80	353	263	170	225	129	155	120	10,5	20,1
5SVH08../D	1,1	80	428	263	170	225	129	155	120	12,1	23,5
5SVH11../D	1,5	90	513	263	170	225	129	155	140	13,6	27
5SVH14..	2,2	90	588	298	170	225	134	174	140	15	33,2
5SVH16..	2,2	90	638	298	170	225	134	174	140	16	34,2
5SVH21..	3	100	773	298	170	225	134	174	160	19,4	40,4
5SVH28..	4	112	948	319	170	225	154	197	160	23	49,4
5SVH33..	5,5	132	1093	375	170	293	168	214	300	29,5	67,1

5svh-2p50-en_b_td

**10SVH SERIES
DIMENSIONS AND WEIGHTS AT 50 Hz**

**e-SVH
HYDROVAR®**

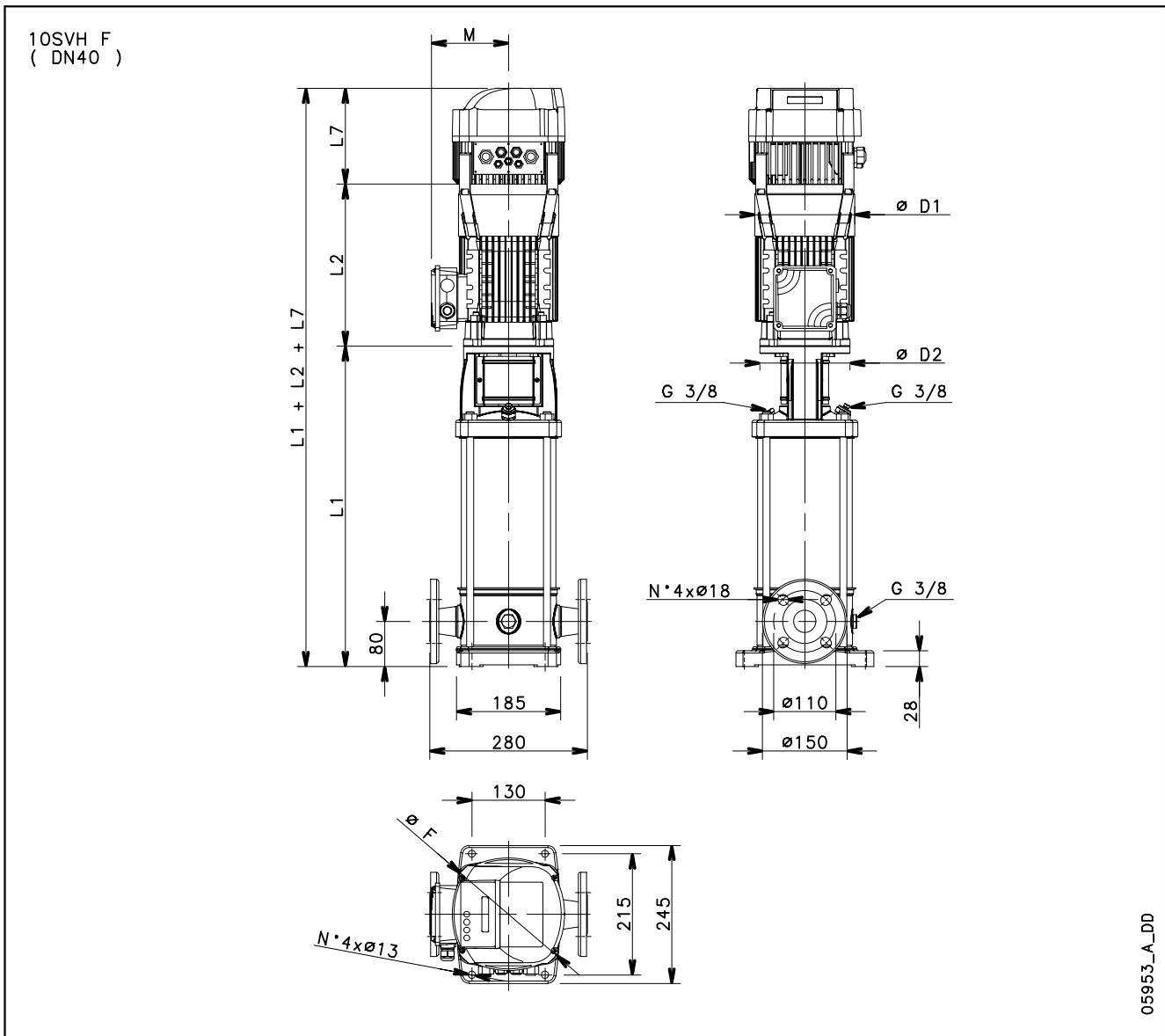

05953_A_DD

PUMP TYPE	MOTOR		DIMENSIONS (mm)							WEIGHT kg	
	kW	SIZE	L1	L2 3 ~	L7	F	M 3 ~	D1 3 ~	D2	PUMP	ELECTRIC PUMP
10SVH04../D	1,5	90	431	263	170	225	129	155	140	17,6	31
10SVH06..	2,2	90	495	298	170	225	134	174	140	19,7	37,9
10SVH08..	3	100	569	298	170	225	134	174	160	22,4	43,4
10SVH11..	4	112	665	319	170	225	154	197	160	25,2	52
10SVH15..	5,5	132	860	375	170	293	168	214	300	35	73
10SVH20..	7,5	132	1020	367	170	293	191	256	300	39,6	96
10SVH21..	11	160	1082	428	170	293	191	256	350	42,2	113

10svh-2p50-en_b_td

15SVH SERIES
DIMENSIONS AND WEIGHTS AT 50 Hz

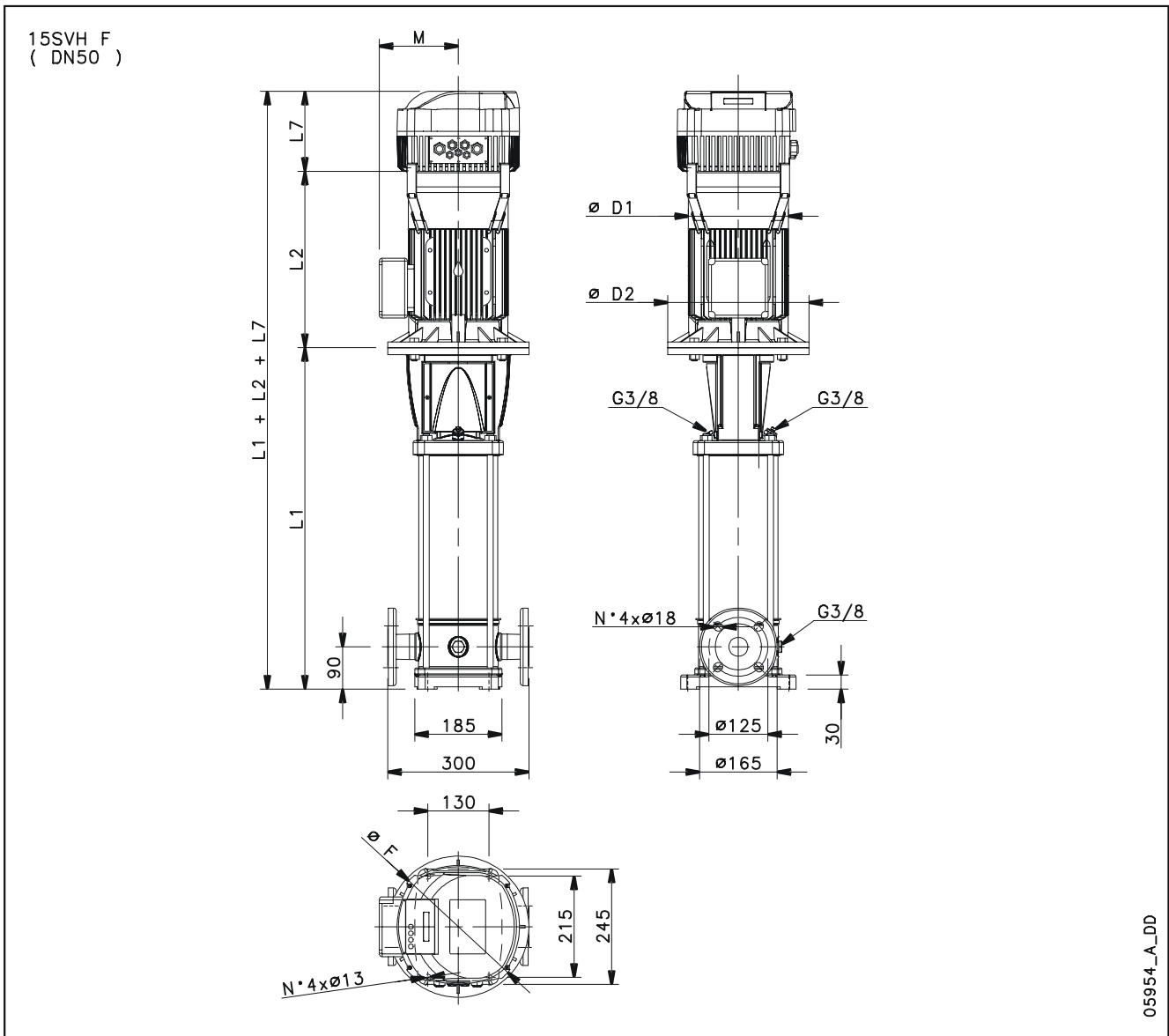

e-SVH
HYDROVAR®

PUMP TYPE	MOTOR		DIMENSIONS (mm)							WEIGHT kg	
	kW	SIZE	L1	L2 3~	L7	F	M 3~	D1 3~	D2	PUMP	ELECTRIC PUMP
15SVH02..	2,2	90	409	298	170	225	134	174	140	16,8	34,7
15SVH03..	3	100	467	298	170	225	134	174	160	19	40
15SVH05..	4	112	563	319	170	225	154	197	160	21,5	47,9
15SVH07..	5,5	132	726	375	170	293	168	214	300	30,2	68
15SVH09..	7,5	132	822	367	170	293	191	256	300	32,8	90
15SVH13..	11	160	1044	428	170	293	191	256	350	41	112
15SVH17..	15	160	1236	494	209	440	240	313	350	46,7	149

15svh-2p50-en_b_ttd

22SVH SERIES DIMENSIONS AND WEIGHTS AT 50 Hz

22SVH F
(DN50)

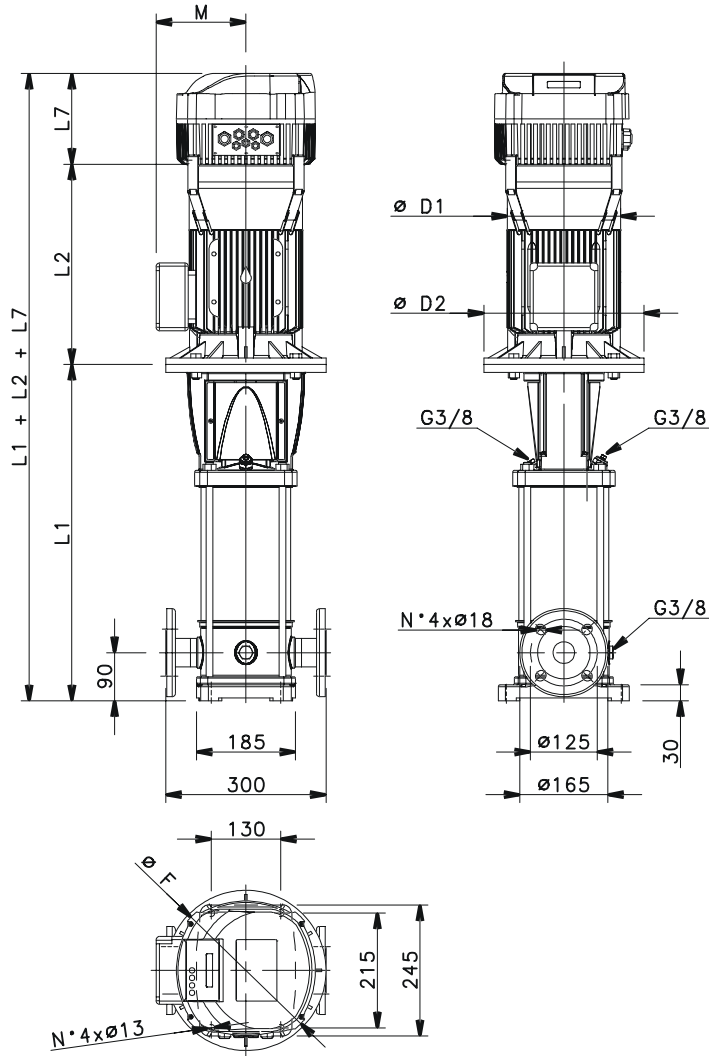

05955_A_DD

PUMP TYPE	MOTOR		DIMENSIONS (mm)							WEIGHT kg	
	kW	SIZE	L1	L2 3~	L7	F	M 3~	D1 3~	D2	PUMP	ELECTRIC PUMP
22SVH01../D	1,1	80	399	263	170	225	129	155	120	15,5	26,9
22SVH03..	3	100	467	298	170	225	134	174	160	19,4	40,4
22SVH04..	4	112	515	319	170	225	154	197	160	20,7	47,1
22SVH05..	5,5	132	630	375	170	293	168	214	300	26,7	65
22SVH07..	7,5	132	726	367	170	293	191	256	300	29,3	86
22SVH10..	11	160	900	428	170	293	191	256	350	35,8	107
22SVH14..	15	160	1092	494	209	440	240	313	350	41,1	144
22SVH17..	18,5	160	1236	494	209	440	240	313	350	45,1	156

22svh-2p50-en_b_td

33SVH SERIES
DIMENSIONS AND WEIGHTS AT 50 Hz

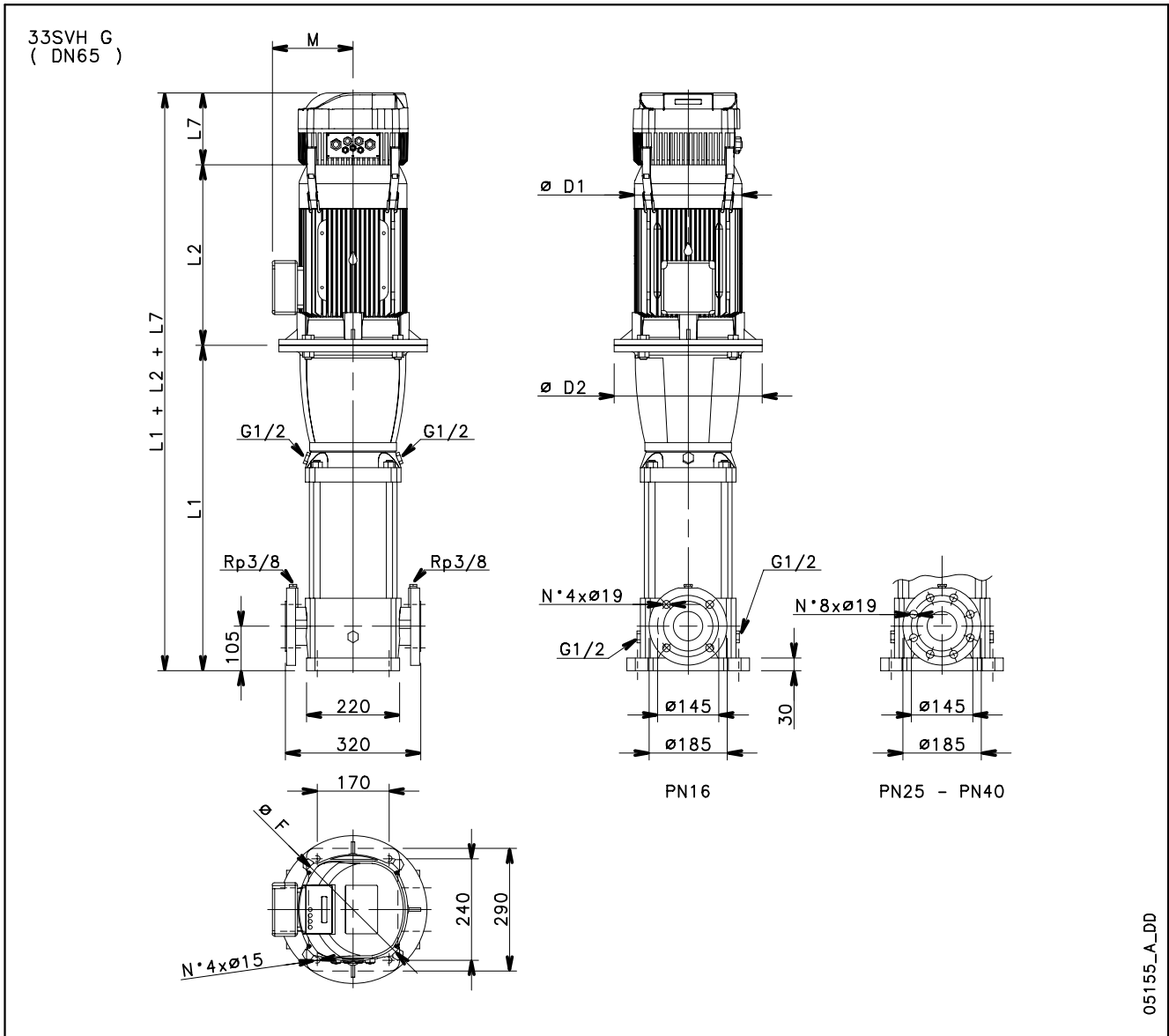

e-SVH
HYDROVAR®

PUMP TYPE	MOTOR		DIMENSIONS (mm)								WEIGHT kg	
	kW	SIZE	L1	L2	L7	F	D1	D2	M	PN	PUMP	ELECTRIC PUMP
33SVH1..	3	100	489	288	170	225	178	164	137	16	52	71
33SVH2..	5,5	132	584	375	170	293	214	300	168	16	61	98,5
33SVH3..	7,5	132	659	367	170	293	256	300	191	16	65	121
33SVH4..	11	160	769	428	170	293	256	350	191	16	73	143
33SVH5..	15	160	844	494	209	440	313	350	240	16	77	179
33SVH6..	15	160	919	494	209	440	313	350	240	25	81	183
33SVH7..	18,5	160	994	494	209	440	313	350	240	25	84	195

33svh-2p50-en_b_td

46SVH SERIES
DIMENSIONS AND WEIGHTS AT 50 Hz

e-SVH
HYDROVAR®

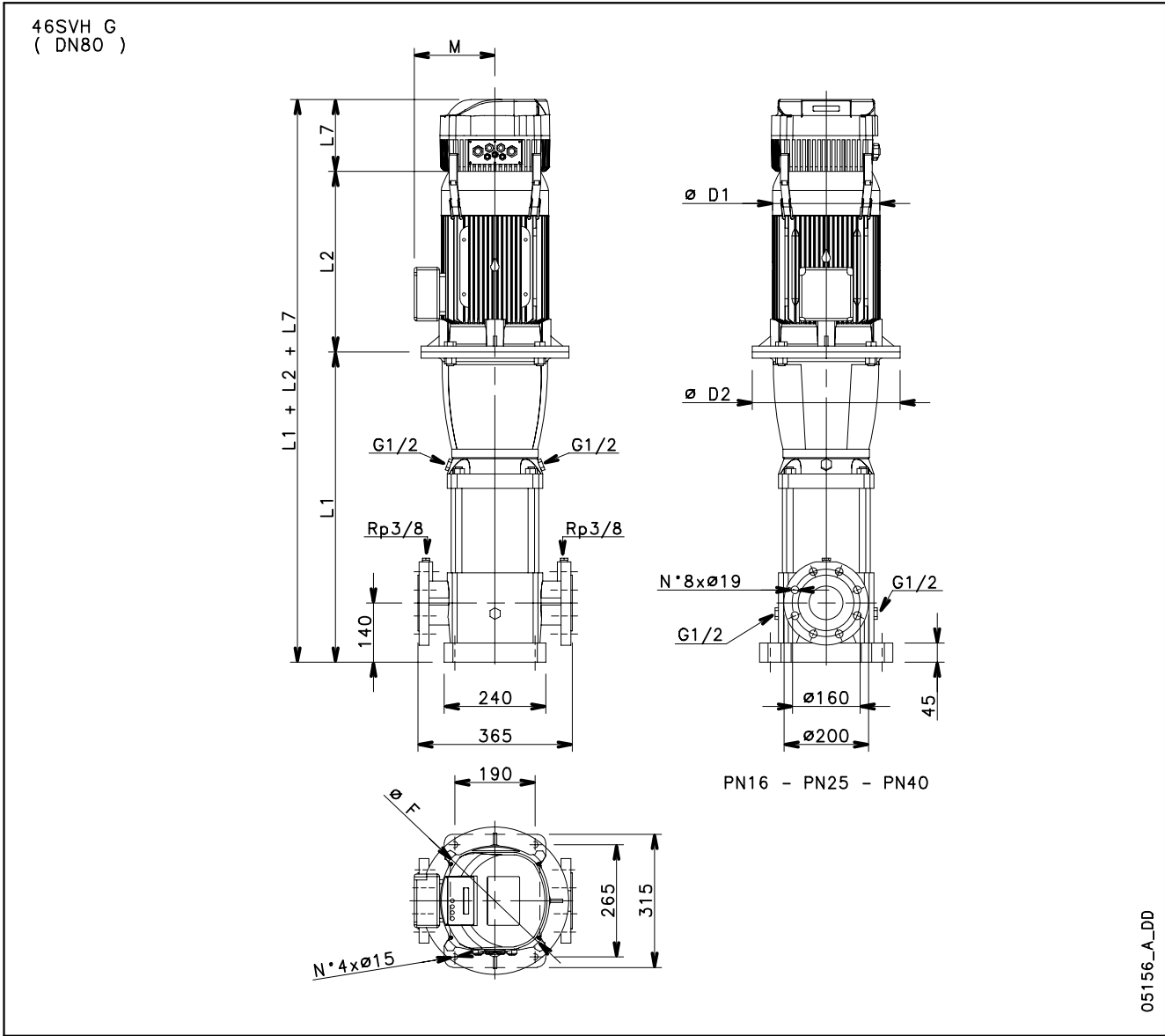

PUMP TYPE	MOTOR		DIMENSIONS (mm)								WEIGHT kg	
	kW	SIZE	L1	L2	L7	F	D1	D2	M	PN	PUMP	ELECTRIC PUMP
46SVH1..	4	112	529	319	170	225	197	164	154	16	58	84,5
46SVH2..	7,5	132	624	367	170	293	256	300	191	16	66	122
46SVH3..	11	160	734	428	170	293	256	350	191	16	74	144
46SVH4..	15	160	809	494	209	440	313	350	240	16	78	180
46SVH6..	22	180	959	494	209	440	313	350	240	25	87	208

46svh-2p50-en_b_td

66SVH SERIES
DIMENSIONS AND WEIGHTS AT 50 Hz

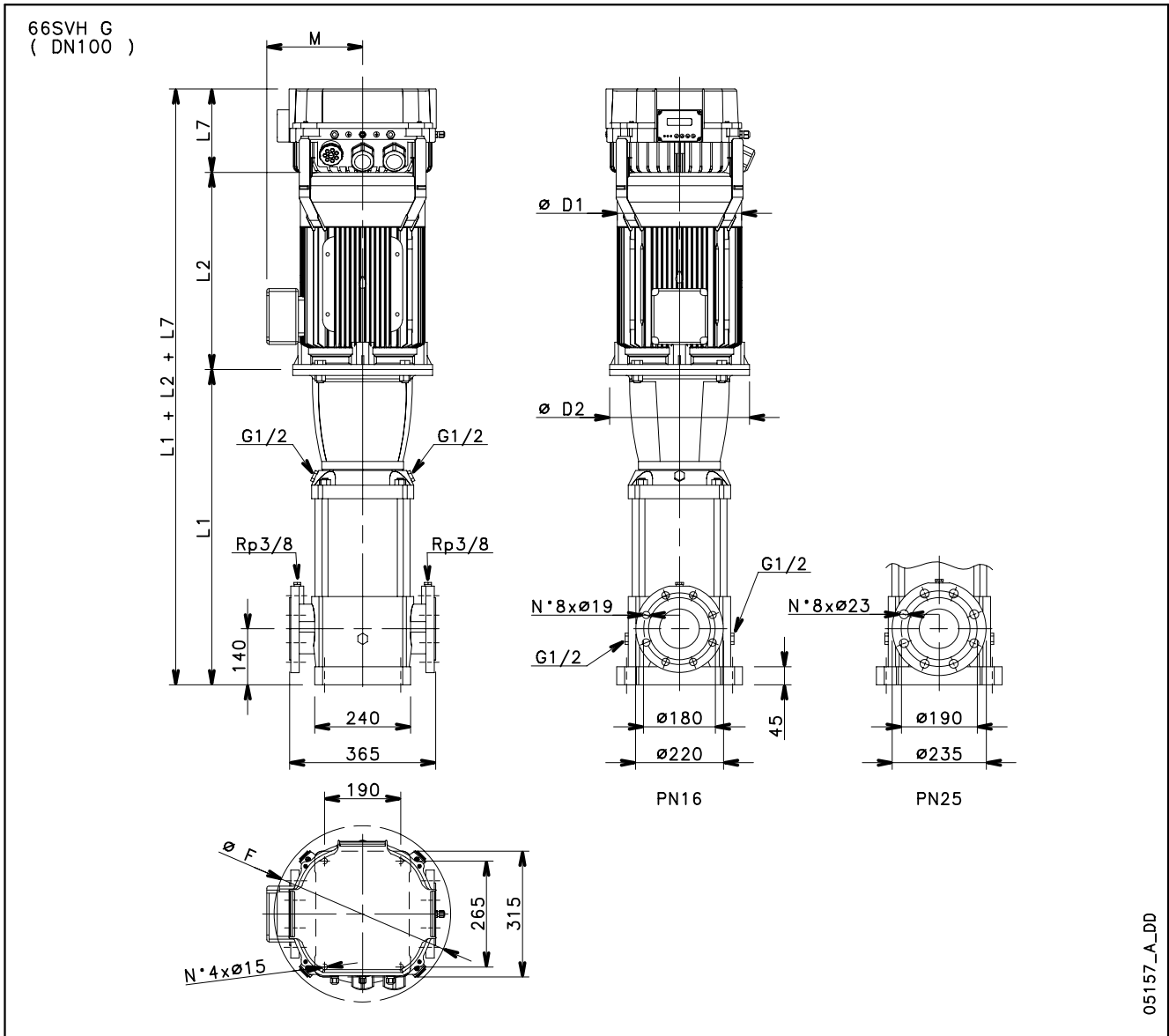

e-SVH
HYDROVAR®

PUMP TYPE	MOTOR		DIMENSIONS (mm)								WEIGHT kg	
	kW	SIZE	L1	L2	L7	F	D1	D2	M	PN	PUMP	ELECTRIC PUMP
66SVH1..	5,5	132	574	375	170	293	214	300	168	16	72	110
66SVH2..	11	160	699	428	170	293	256	350	191	16	81	151
66SVH3..	18,5	160	789	494	209	440	313	350	240	16	86	197
66SVH4..	22	180	879	494	209	440	313	350	240	16	93	214

66svh-2p50-en_b_td

92SVH SERIES
DIMENSIONS AND WEIGHTS AT 50 Hz

92SVH G
(DN100)

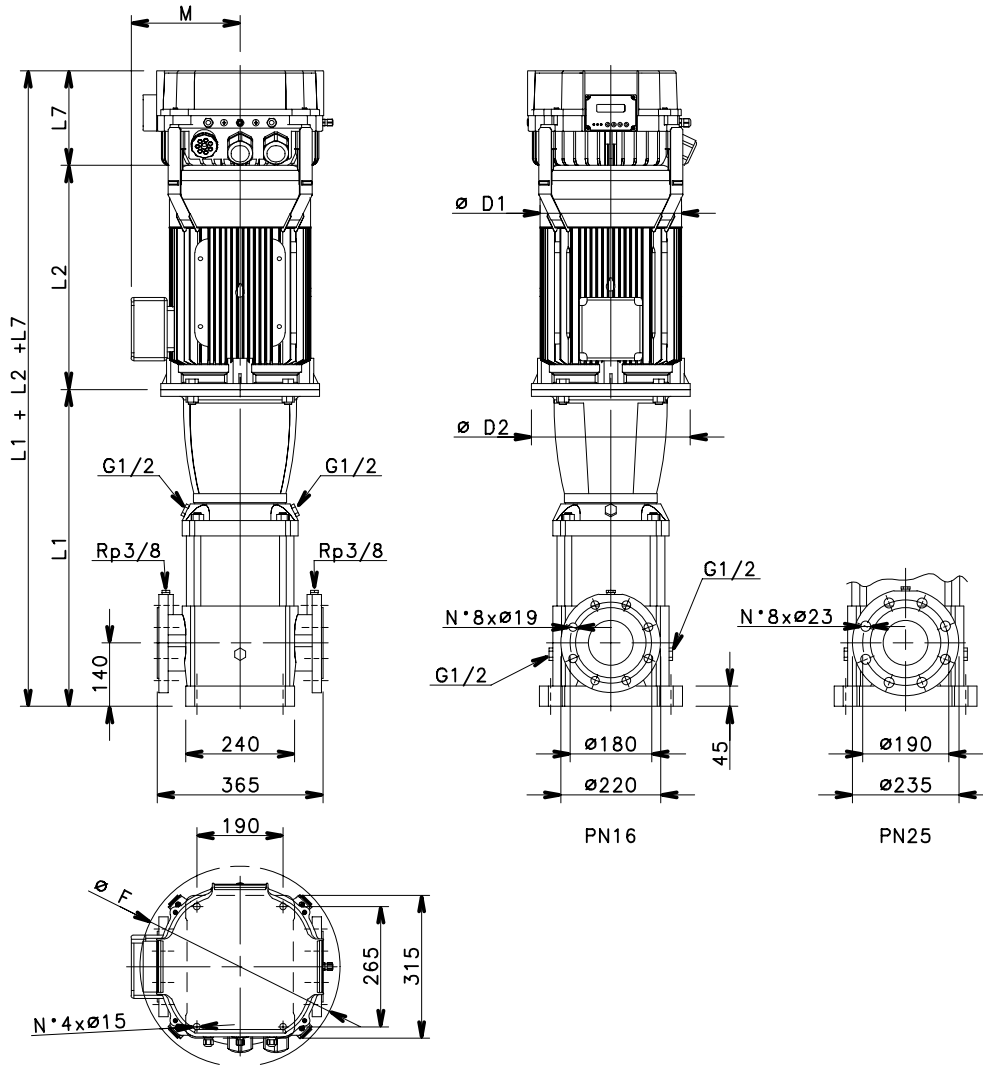

05158_A_DD

PUMP TYPE	MOTOR		DIMENSIONS (mm)								WEIGHT kg	
	kW	SIZE	L1	L2	L7	F	D1	D2	M	PN	PUMP	ELECTRIC PUMP
92SVH1..	7,5	132	574	367	170	293	256	300	191	16	71	127
92SVH2..	15	160	699	494	209	440	313	350	240	16	80	182
92SVH3..	22	180	789	494	209	440	313	350	240	16	87	208

92svh-2p50-en_b_td

**1SVH SERIES
OPERATING CHARACTERISTICS AT 30..50 Hz**

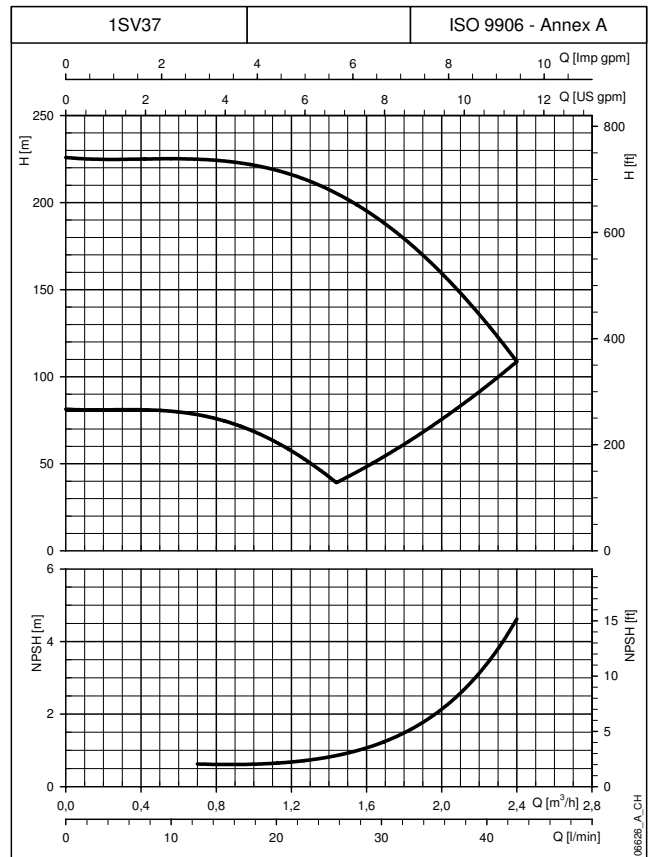
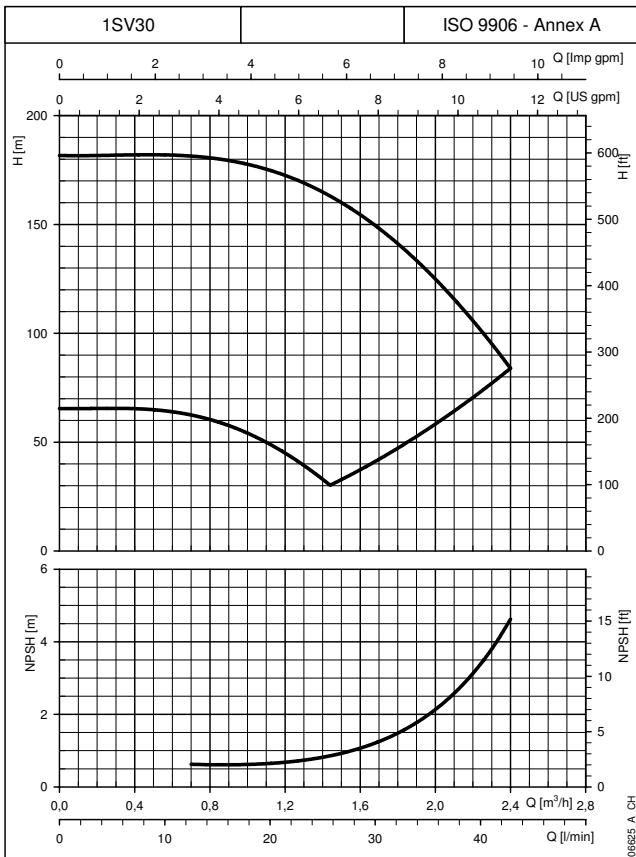
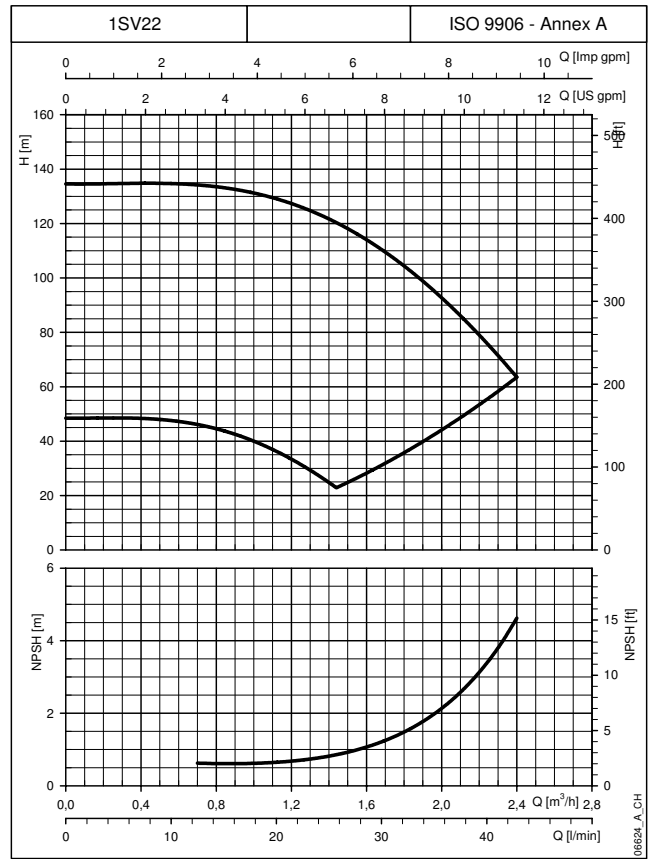
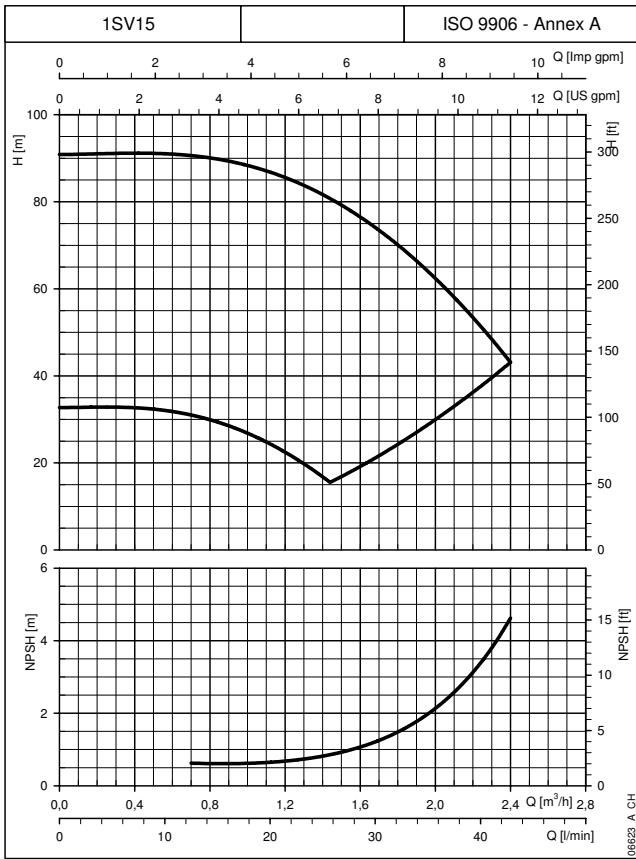

The curves show the performance with one pump running to the minimum and maximum speed.
These performances are valid for liquids with density $\rho = 1.0 \text{ Kg/dm}^3$ and kinematic viscosity $\nu = 1 \text{ mm}^2/\text{s}$.

**e-SVH
HYDROVAR®**

**3SVH SERIES
OPERATING CHARACTERISTICS AT 30..50 Hz**

**e-SVH
HYDROVAR®**

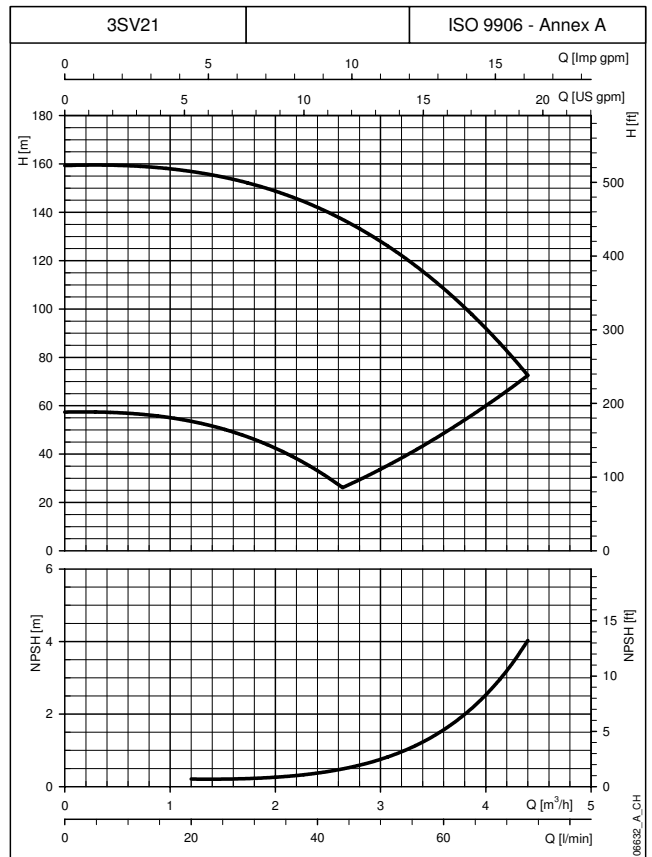
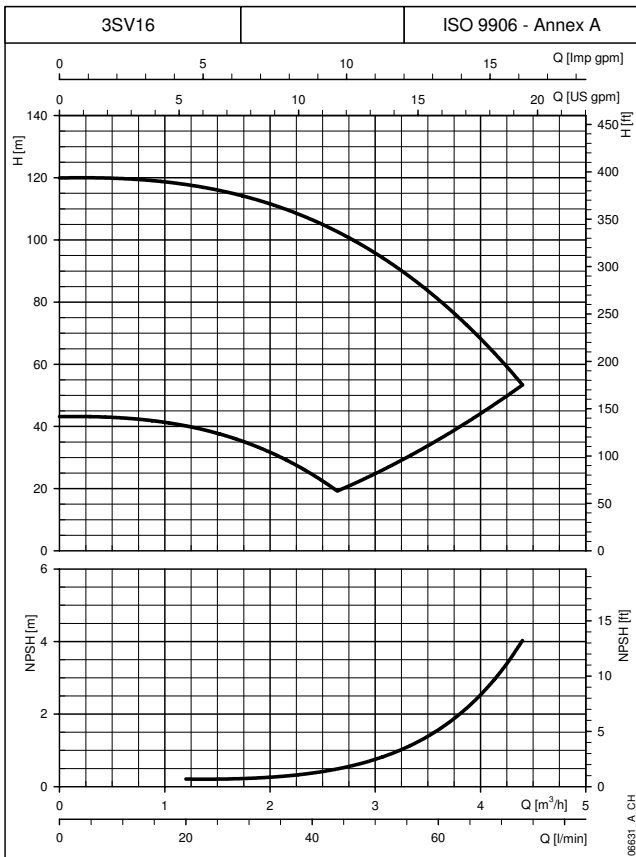
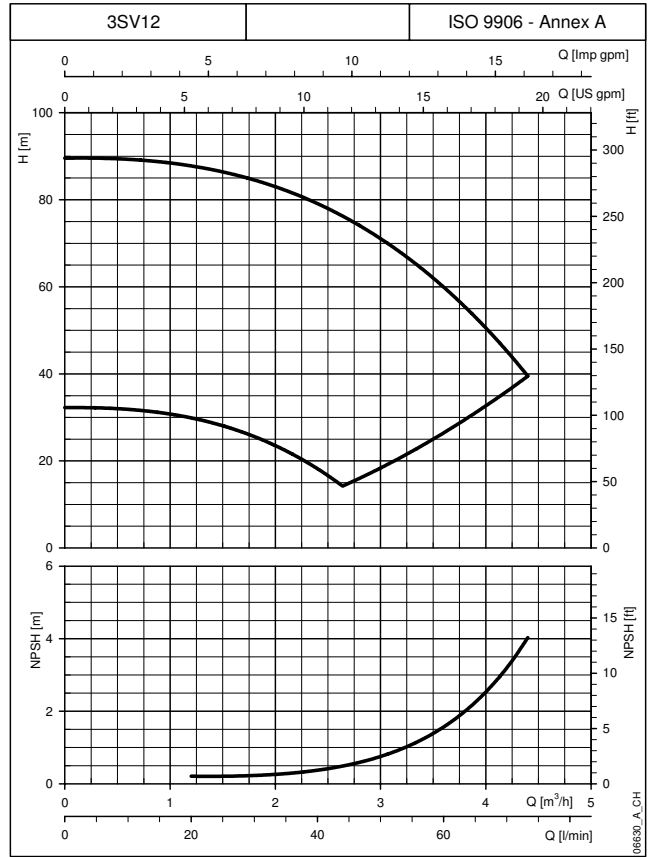
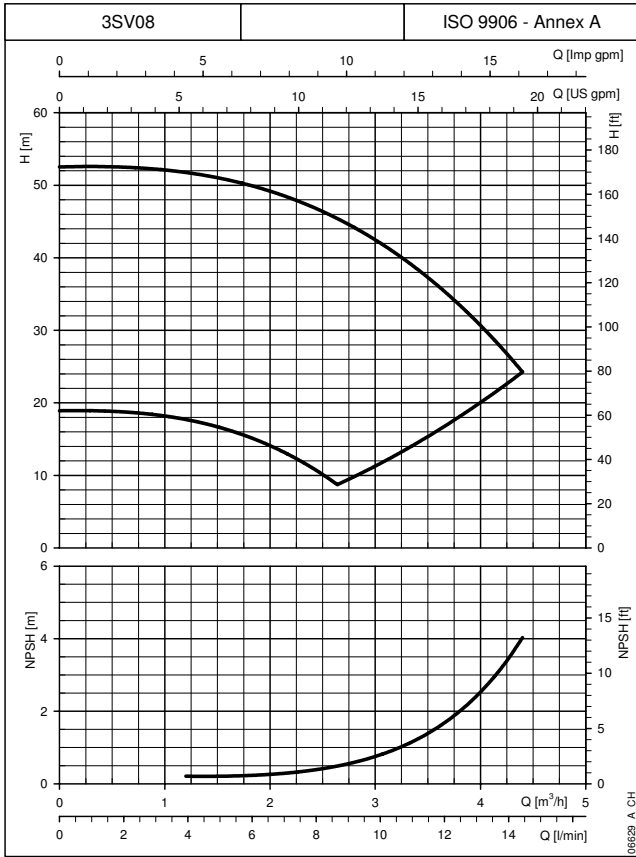

The curves show the performance with one pump running to the minimum and maximum speed. These performances are valid for liquids with density $\rho = 1.0 \text{ Kg/dm}^3$ and kinematic viscosity $\nu = 1 \text{ mm}^2/\text{s}$.

**3SVH SERIES
OPERATING CHARACTERISTICS AT 30..50 Hz**

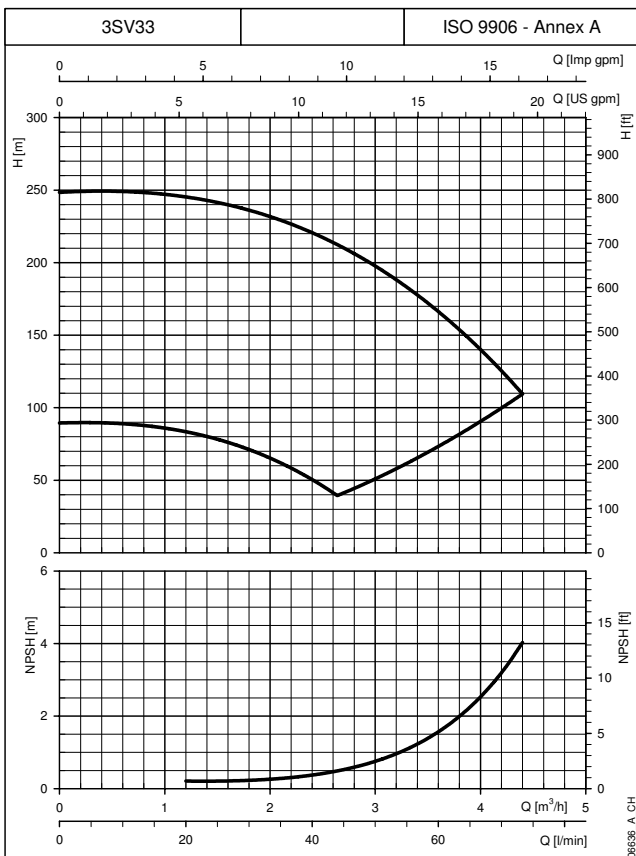
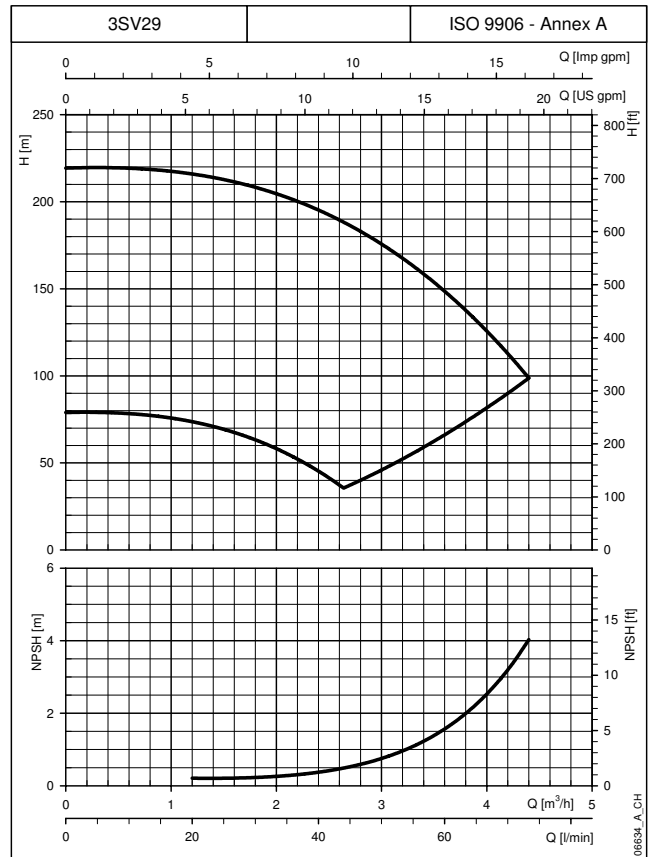
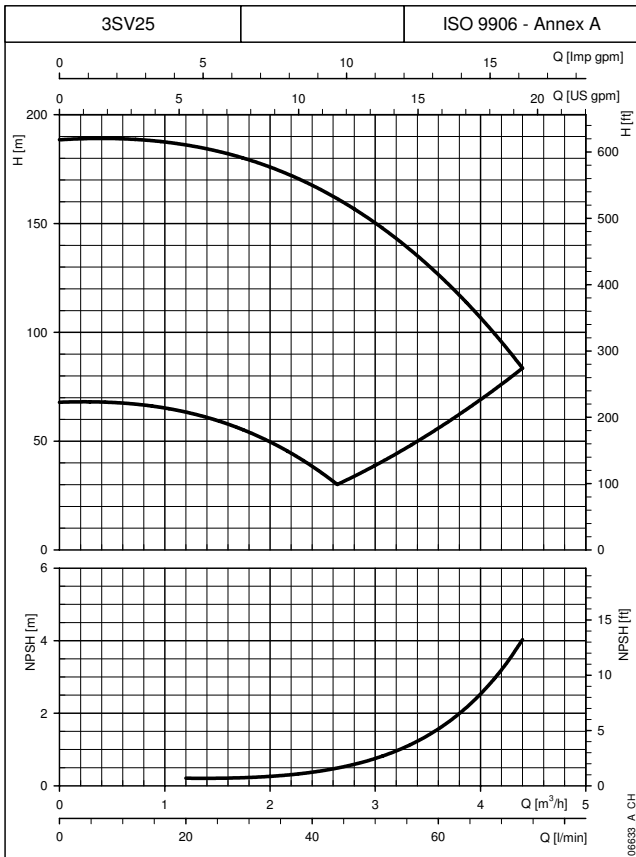

The curves show the performance with one pump running to the minimum and maximum speed.
These performances are valid for liquids with density $\rho = 1.0 \text{ Kg/dm}^3$ and kinematic viscosity $\nu = 1 \text{ mm}^2/\text{s}$.

**e-SVH
HYDROVAR®**

**5SVH SERIES
OPERATING CHARACTERISTICS AT 30..50 Hz**

**e-SVH
HYDROVAR®**

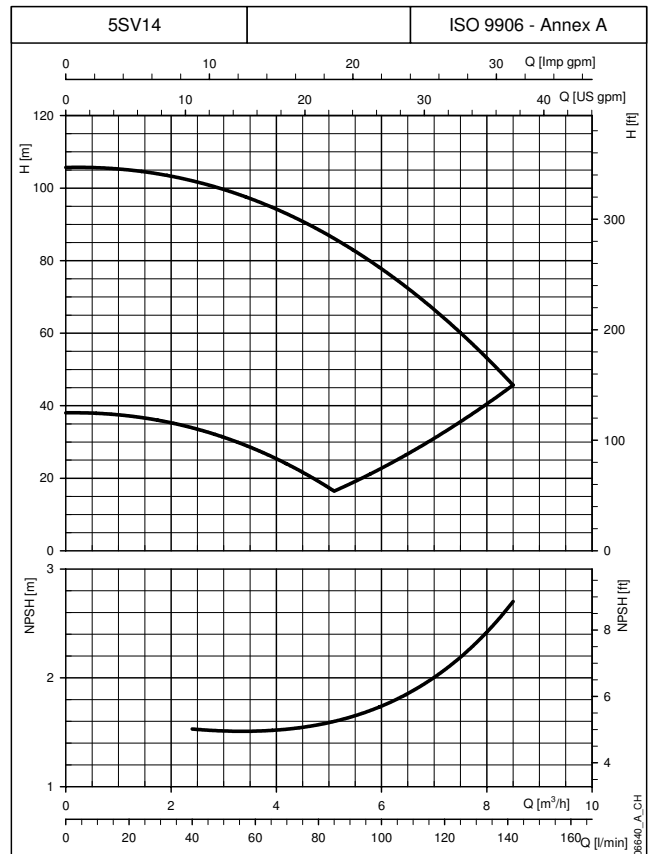
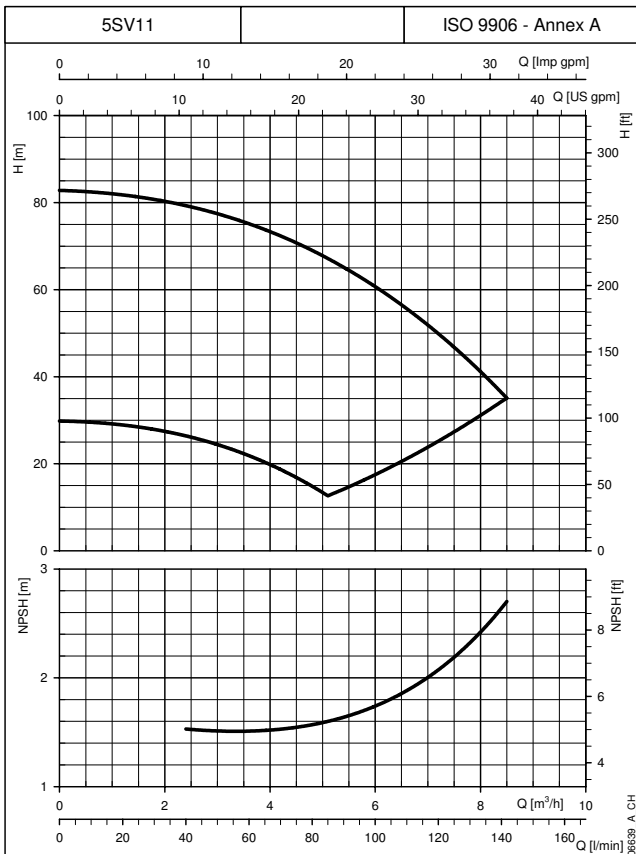
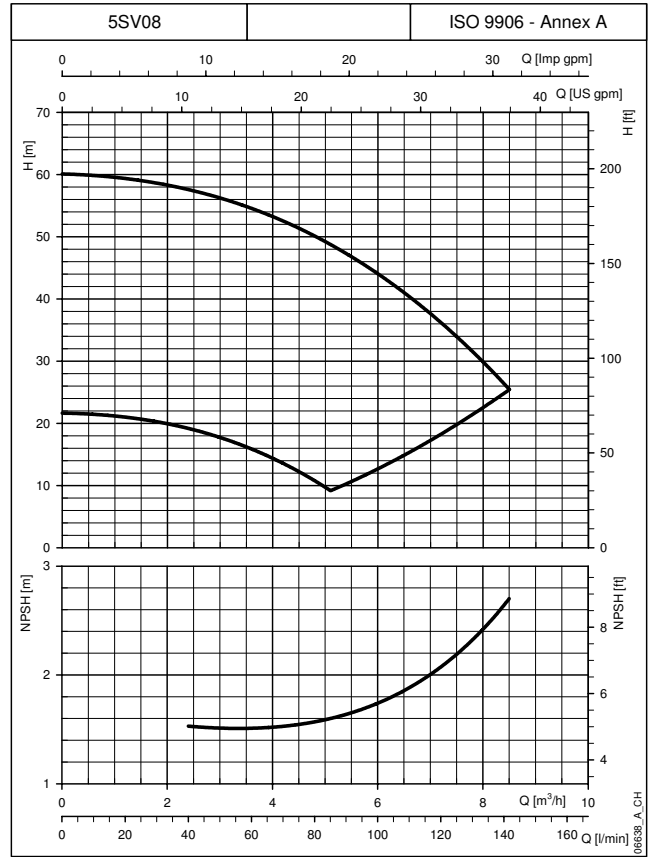
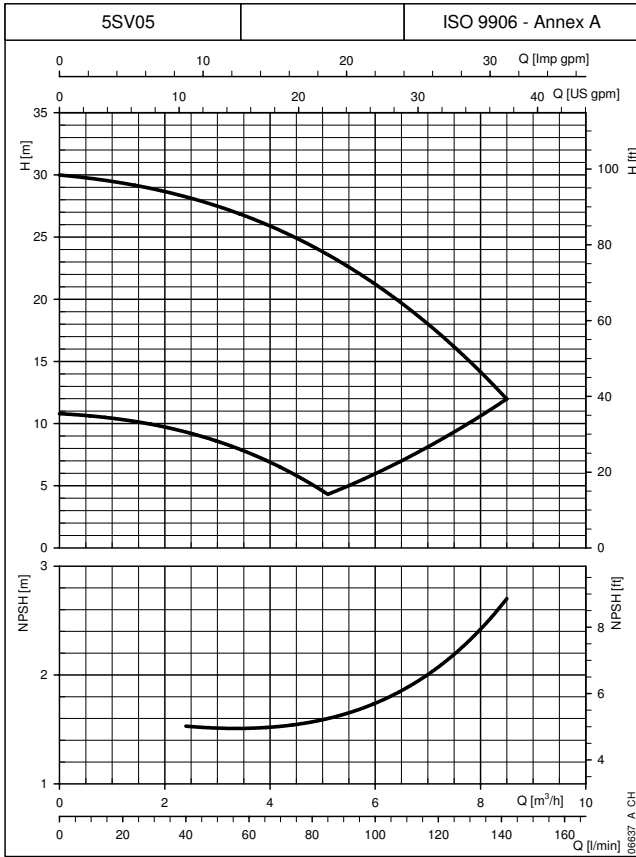

The curves show the performance with one pump running to the minimum and maximum speed.
These performances are valid for liquids with density $\rho = 1.0 \text{ Kg/dm}^3$ and kinematic viscosity $\nu = 1 \text{ mm}^2/\text{s}$.

**5SVH SERIES
OPERATING CHARACTERISTICS AT 30..50 Hz**

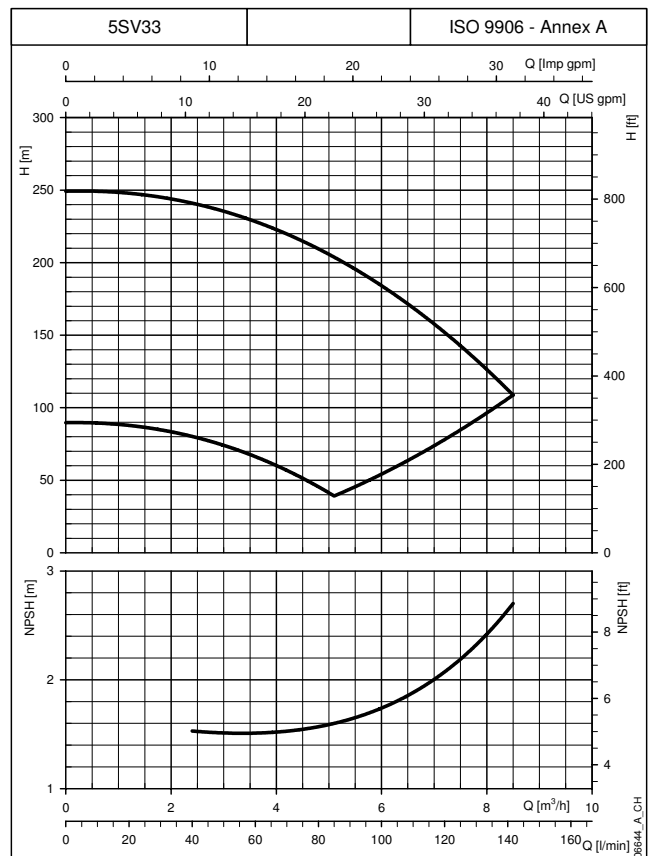
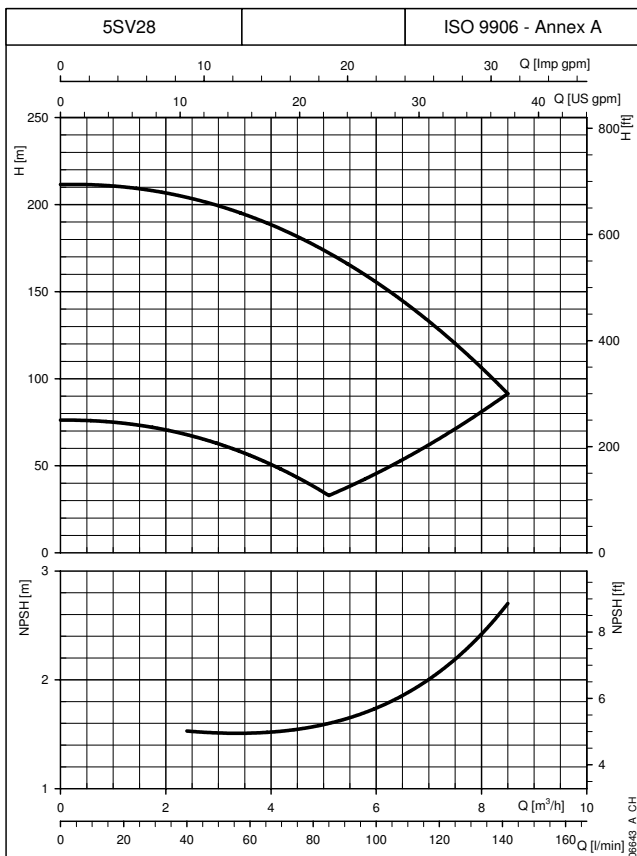
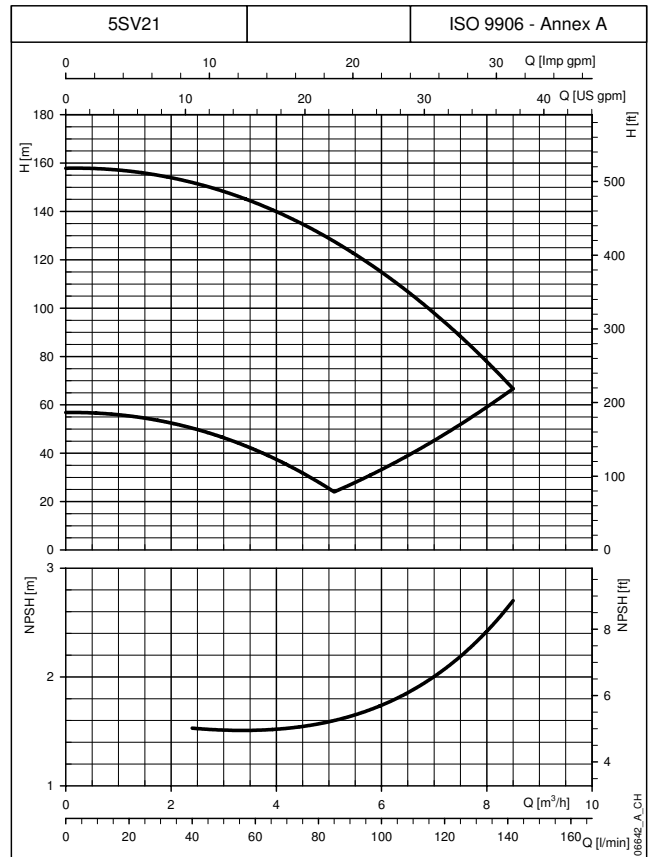
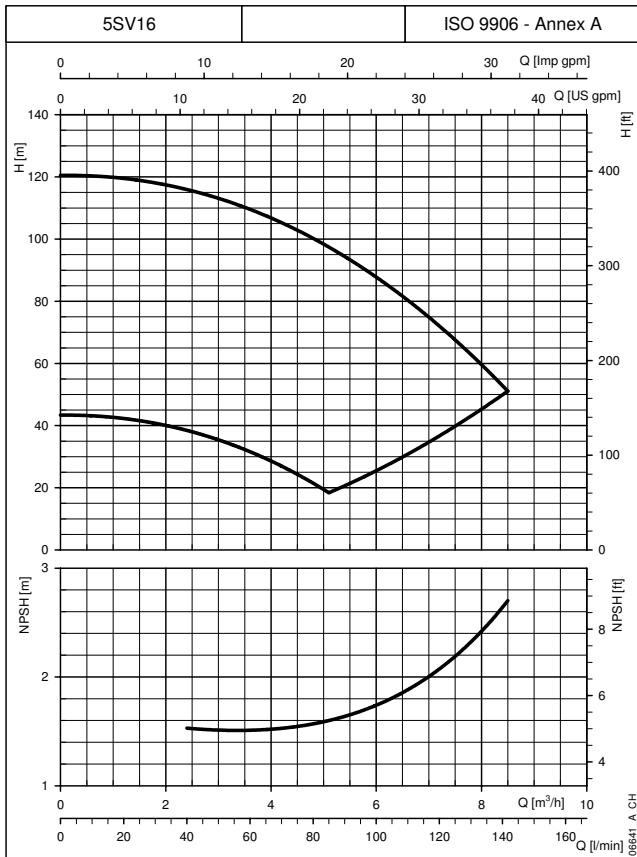

The curves show the performance with one pump running to the minimum and maximum speed.
These performances are valid for liquids with density $\rho = 1.0 \text{ Kg/dm}^3$ and kinematic viscosity $\nu = 1 \text{ mm}^2/\text{s}$.

**e-SVH
HYDROVAR®**

**10SVH SERIES
OPERATING CHARACTERISTICS AT 30..50 Hz**

**e-SVH
HYDROVAR®**

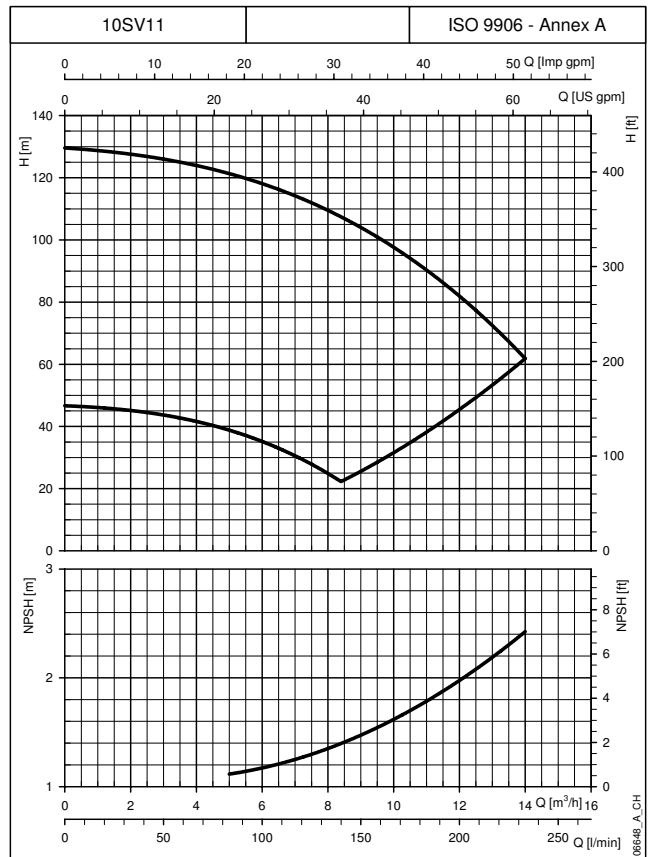
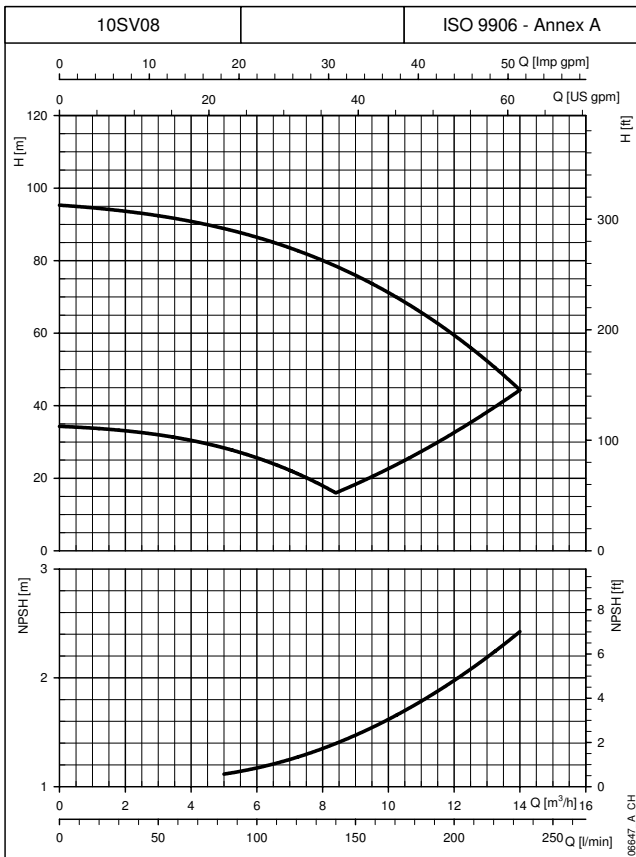
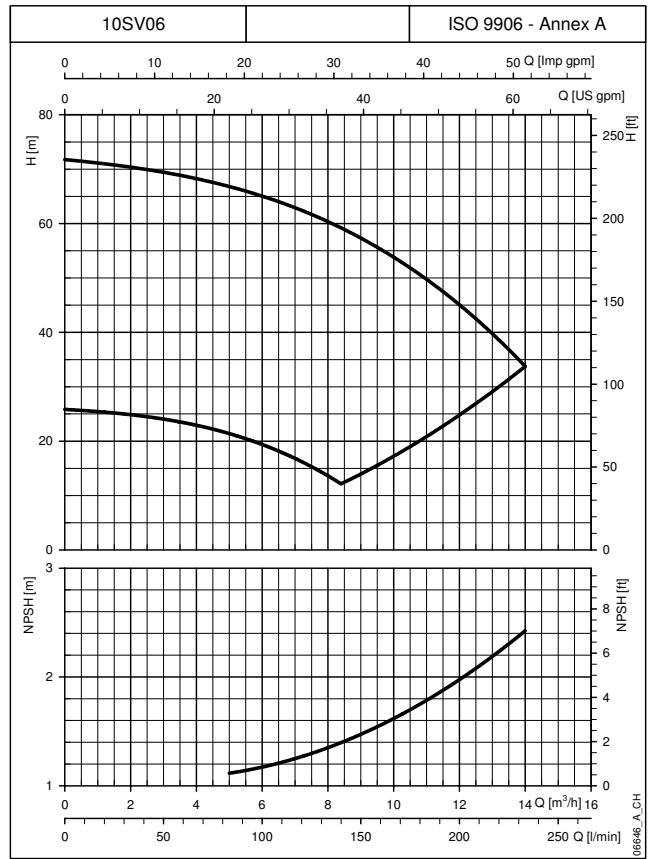
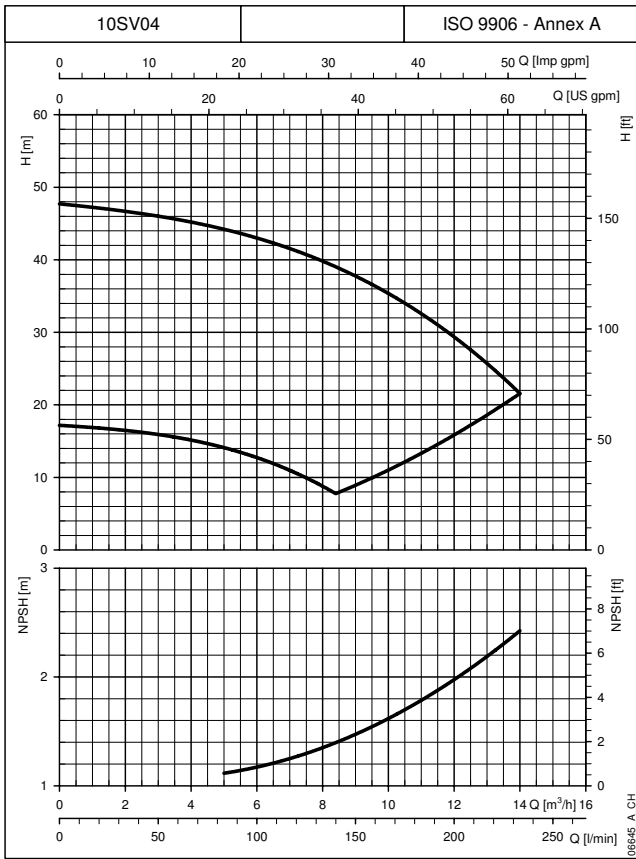

The curves show the performance with one pump running to the minimum and maximum speed.
These performances are valid for liquids with density $\rho = 1.0 \text{ Kg/dm}^3$ and kinematic viscosity $\nu = 1 \text{ mm}^2/\text{s}$.

**10SVH SERIES
OPERATING CHARACTERISTICS AT 30..50 Hz**

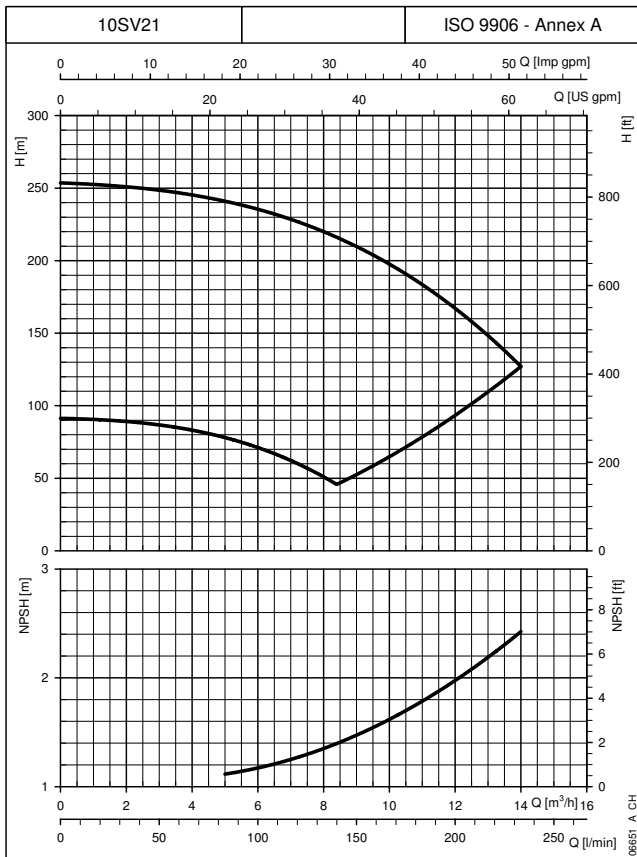
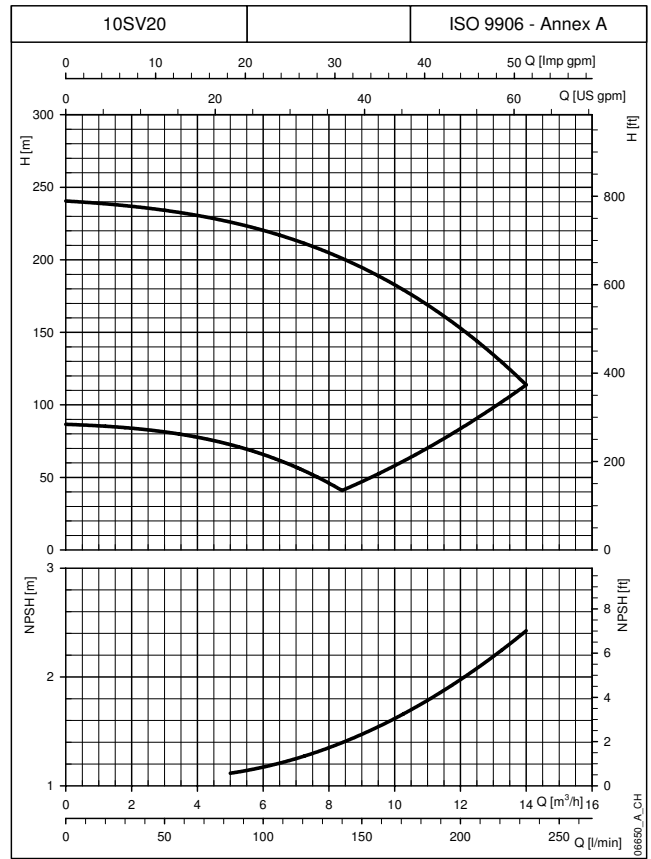
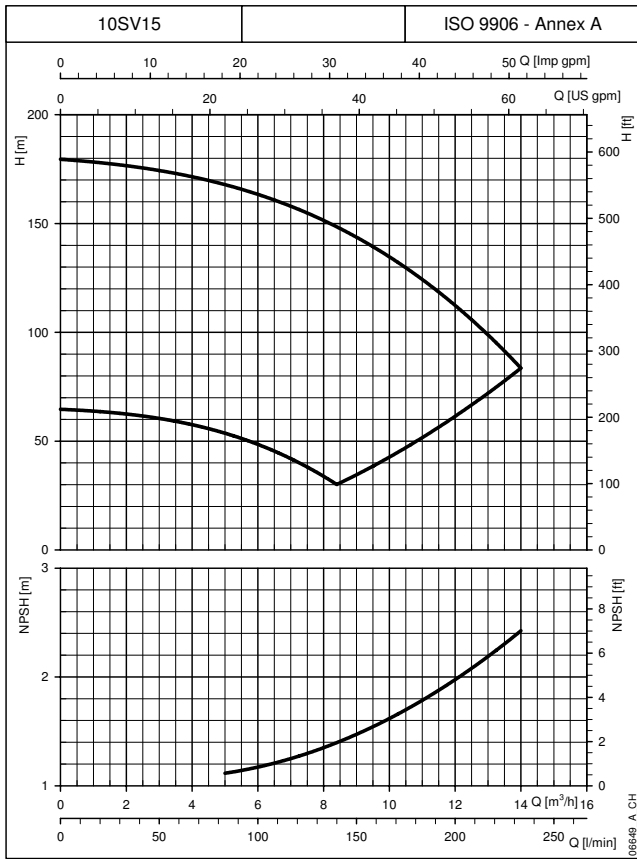

The curves show the performance with one pump running to the minimum and maximum speed.
These performances are valid for liquids with density $\rho = 1.0 \text{ Kg/dm}^3$ and kinematic viscosity $\nu = 1 \text{ mm}^2/\text{s}$.

**e-SVH
HYDROVAR®**

**15SVH SERIES
OPERATING CHARACTERISTICS AT 30..50 Hz**

**e-SVH
HYDROVAR®**

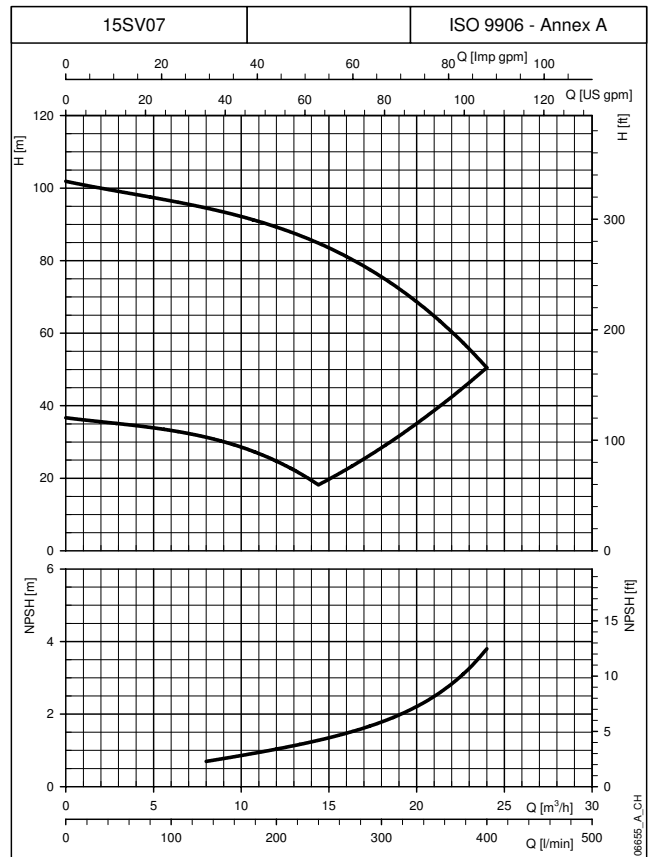
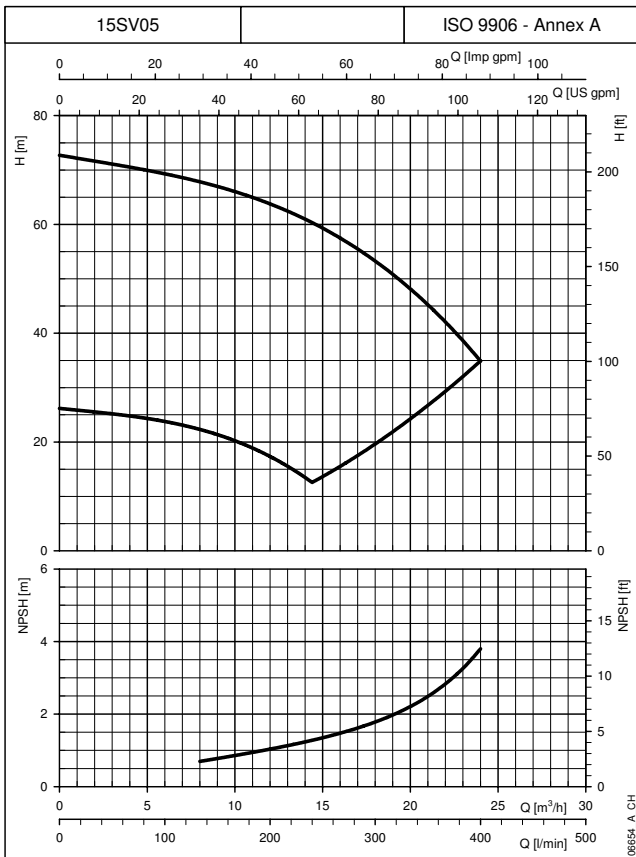
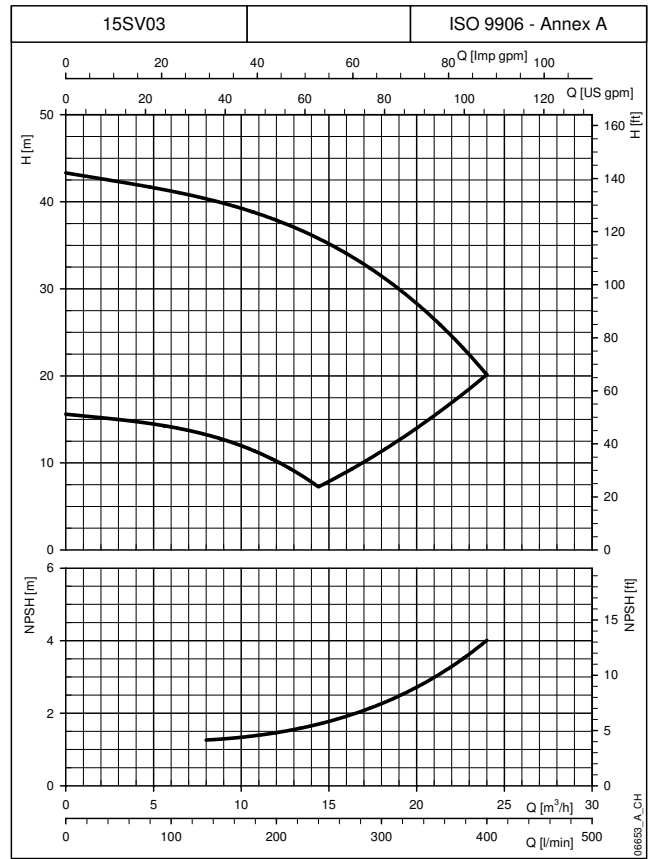
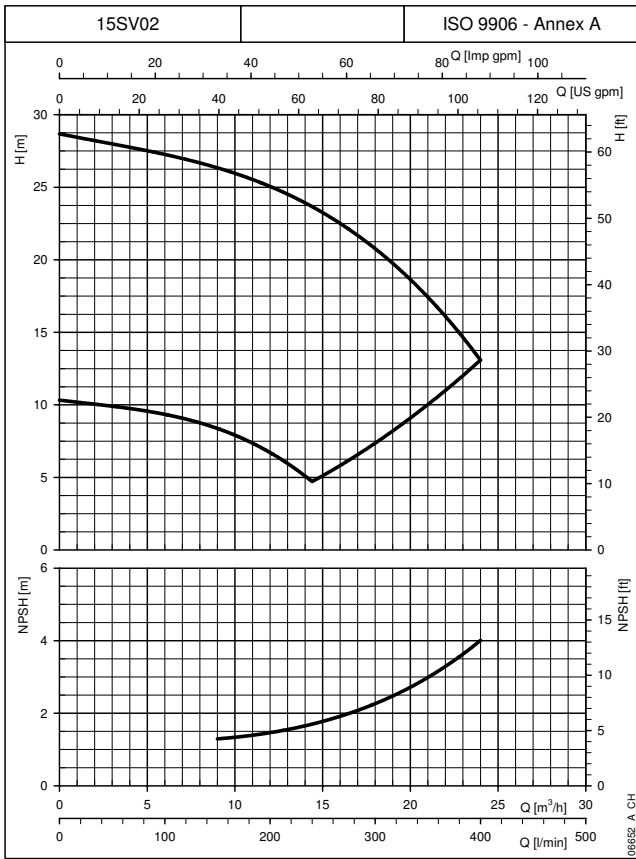

The curves show the performance with one pump running to the minimum and maximum speed.
These performances are valid for liquids with density $\rho = 1.0 \text{ Kg/dm}^3$ and kinematic viscosity $\nu = 1 \text{ mm}^2/\text{s}$.

**15SVH SERIES
OPERATING CHARACTERISTICS AT 30..50 Hz**

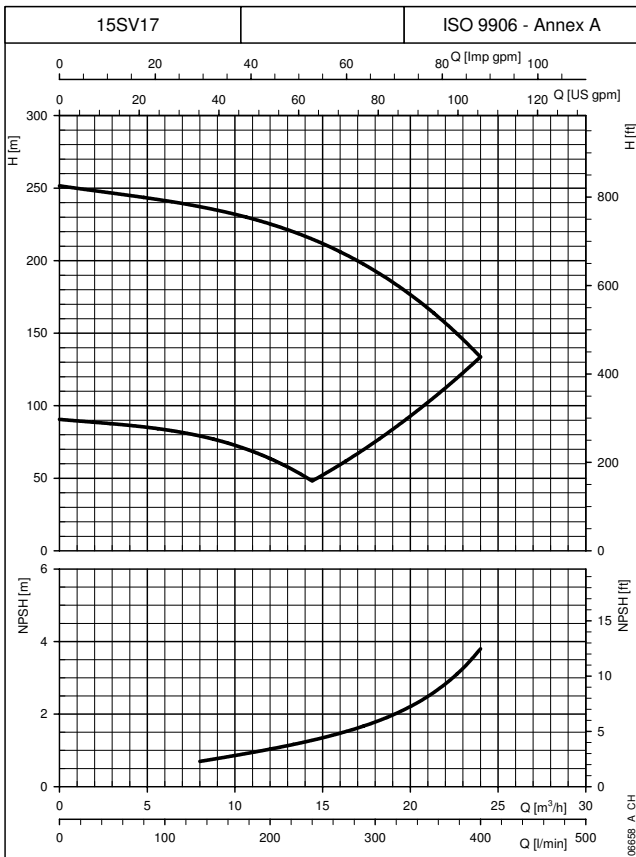
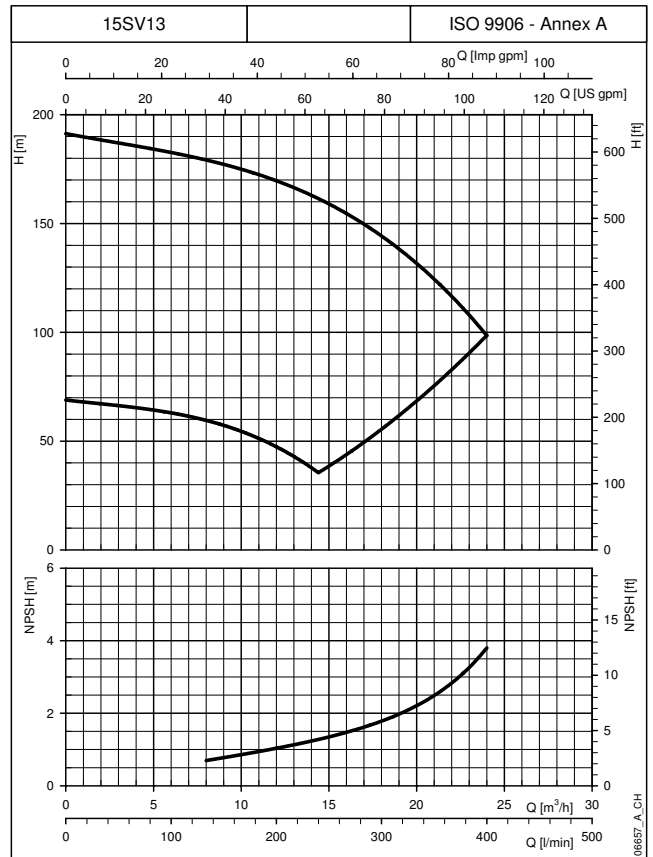
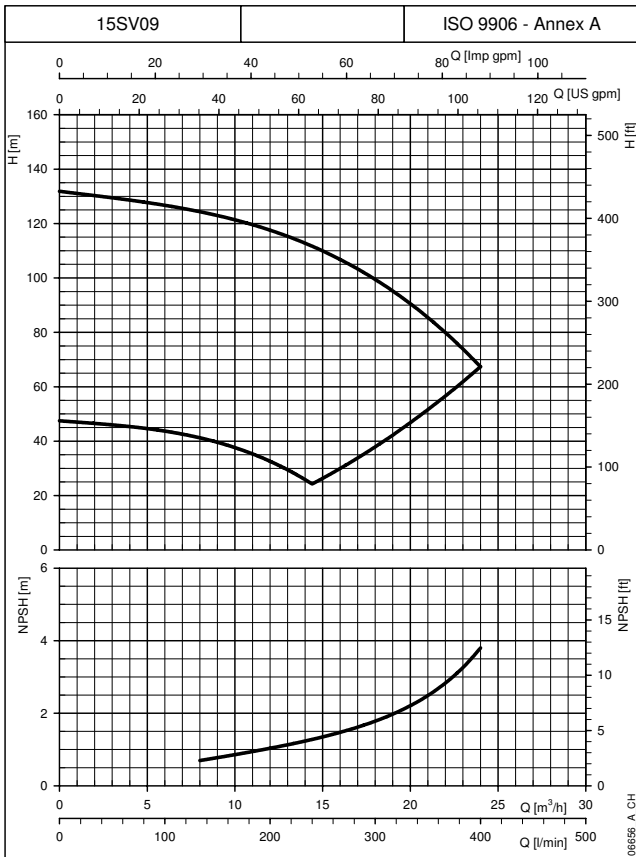

**e-SVH
HYDROVAR®**

The curves show the performance with one pump running to the minimum and maximum speed.
These performances are valid for liquids with density $\rho = 1.0 \text{ Kg/dm}^3$ and kinematic viscosity $\nu = 1 \text{ mm}^2/\text{s}$.

22SVH SERIES OPERATING CHARACTERISTICS AT 30..50 Hz

**e-SVH
HYDROVAR®**

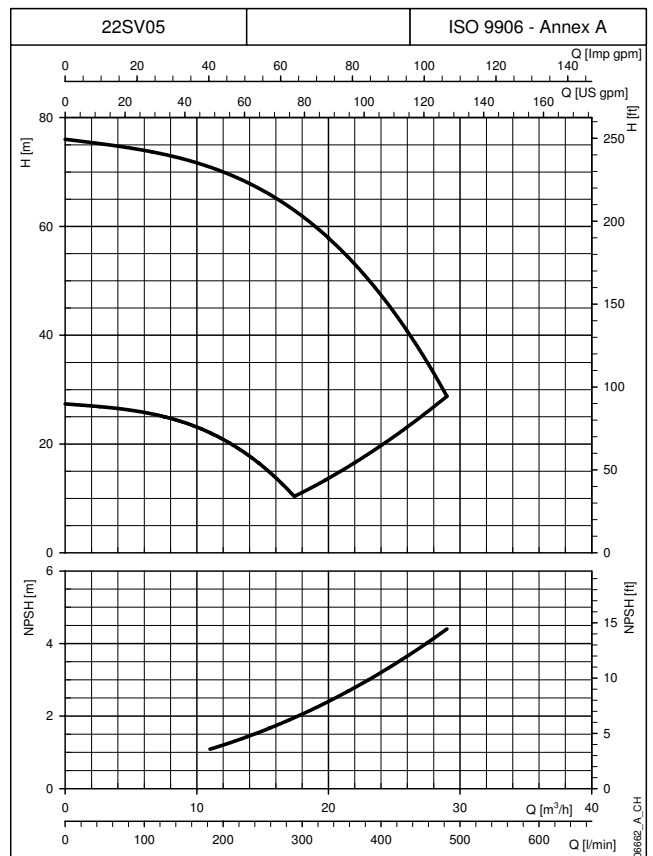
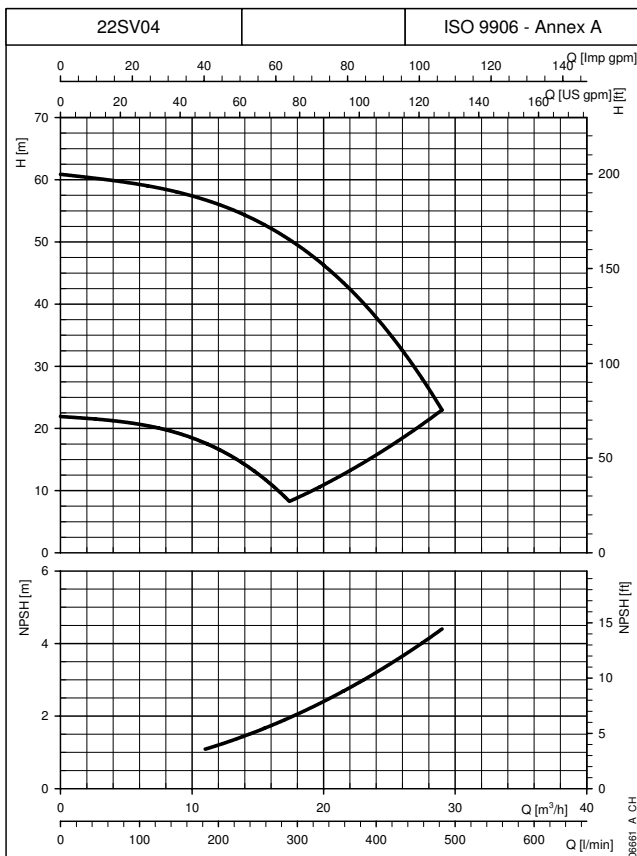
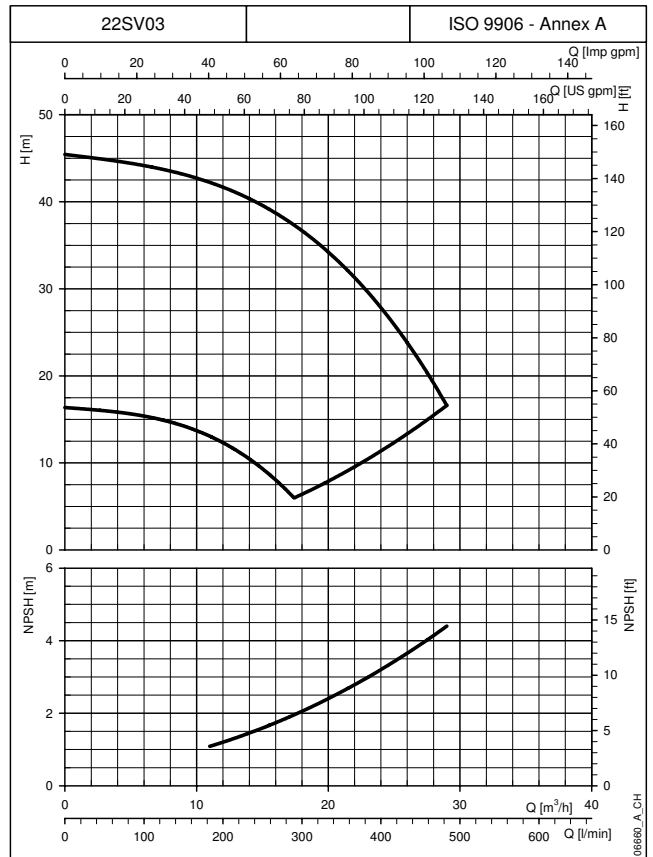
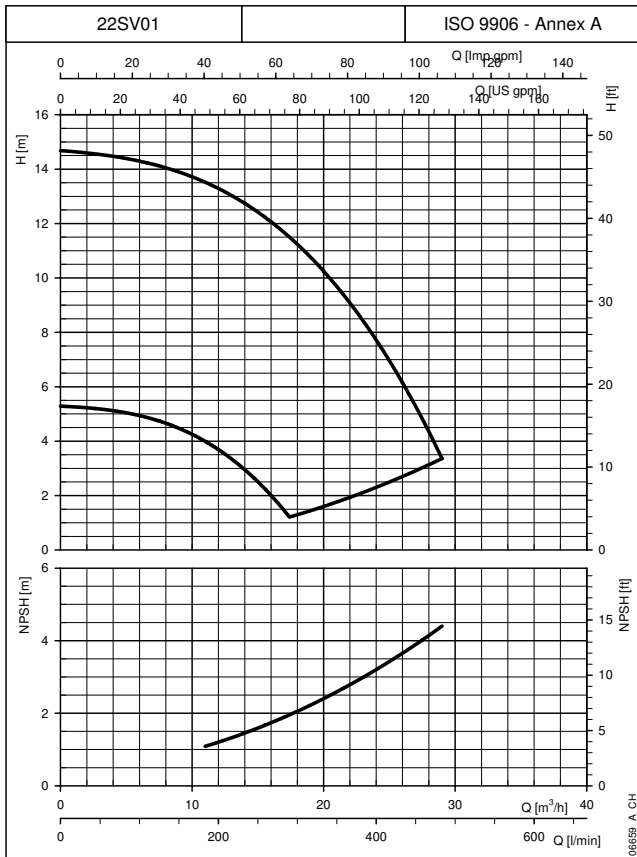

The curves show the performance with one pump running to the minimum and maximum speed.
These performances are valid for liquids with density $\rho = 1.0 \text{ Kg/dm}^3$ and kinematic viscosity $\nu = 1 \text{ mm}^2/\text{s}$.

**22SVH SERIES
OPERATING CHARACTERISTICS AT 30..50 Hz**

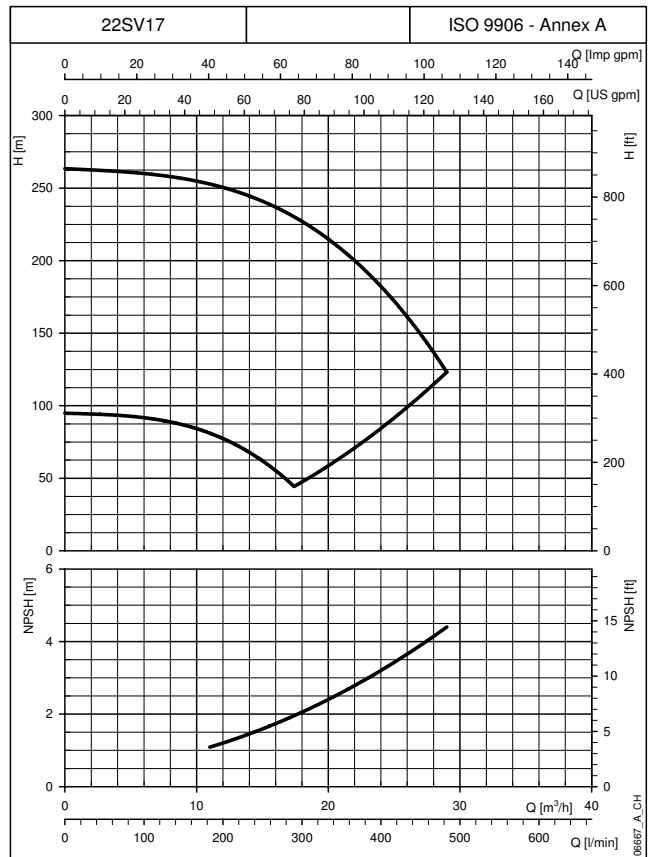
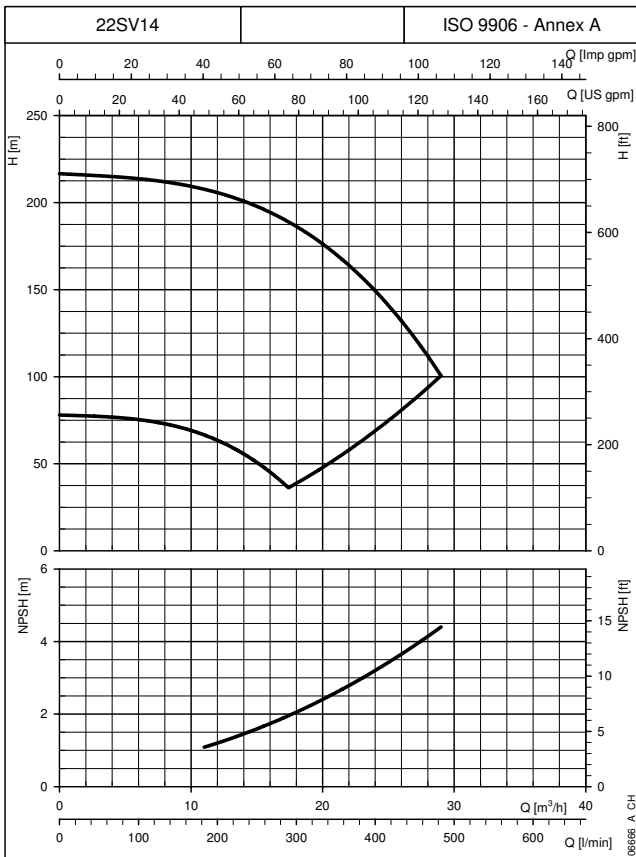
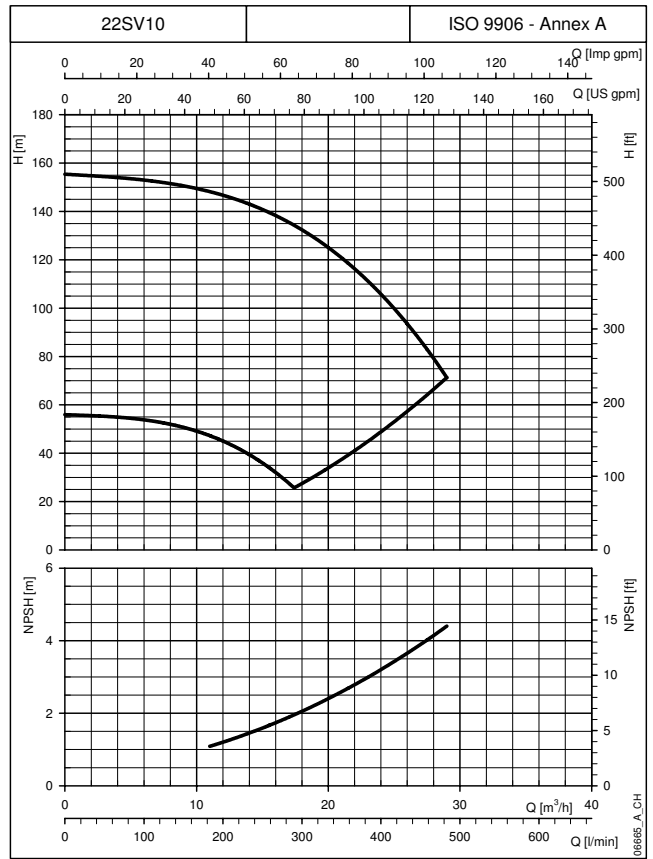
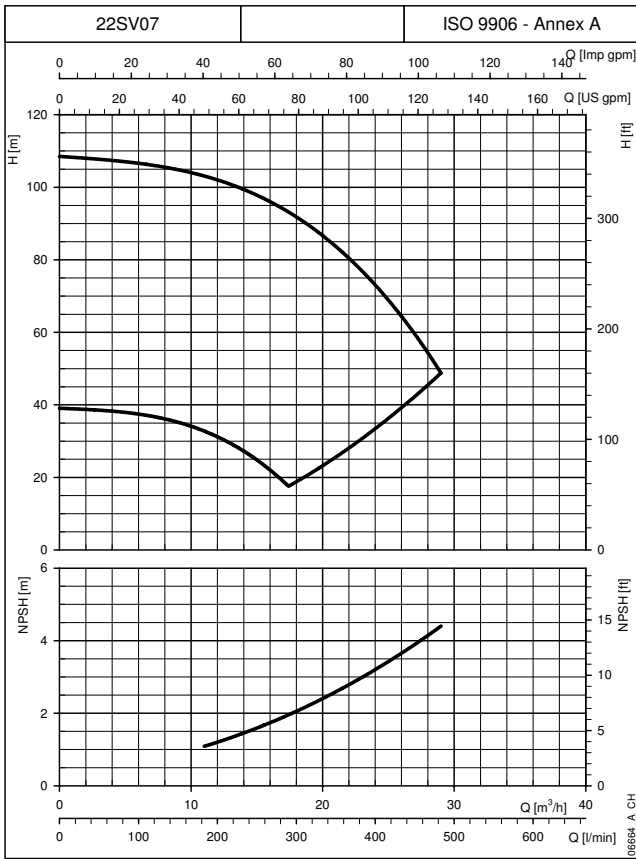

The curves show the performance with one pump running to the minimum and maximum speed.
These performances are valid for liquids with density $\rho = 1.0 \text{ Kg/dm}^3$ and kinematic viscosity $\nu = 1 \text{ mm}^2/\text{s}$.

**e-SVH
HYDROVAR®**

**33SVH SERIES
OPERATING CHARACTERISTICS AT 30..50 Hz**

**e-SVH
HYDROVAR®**

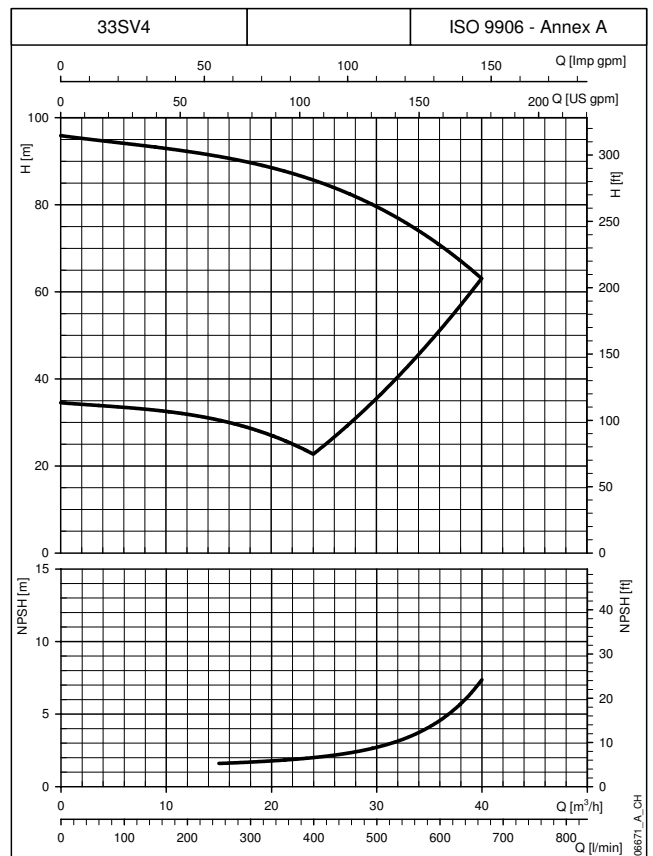
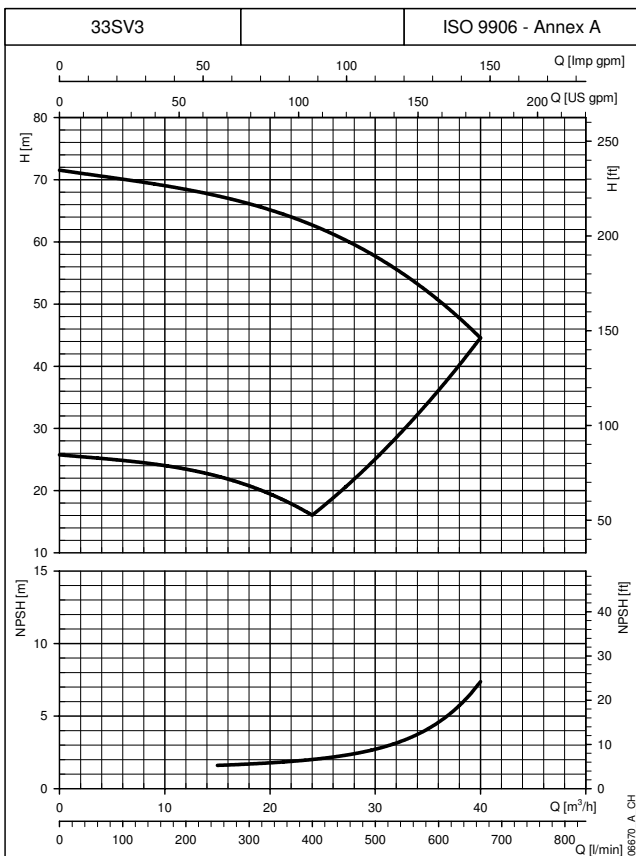
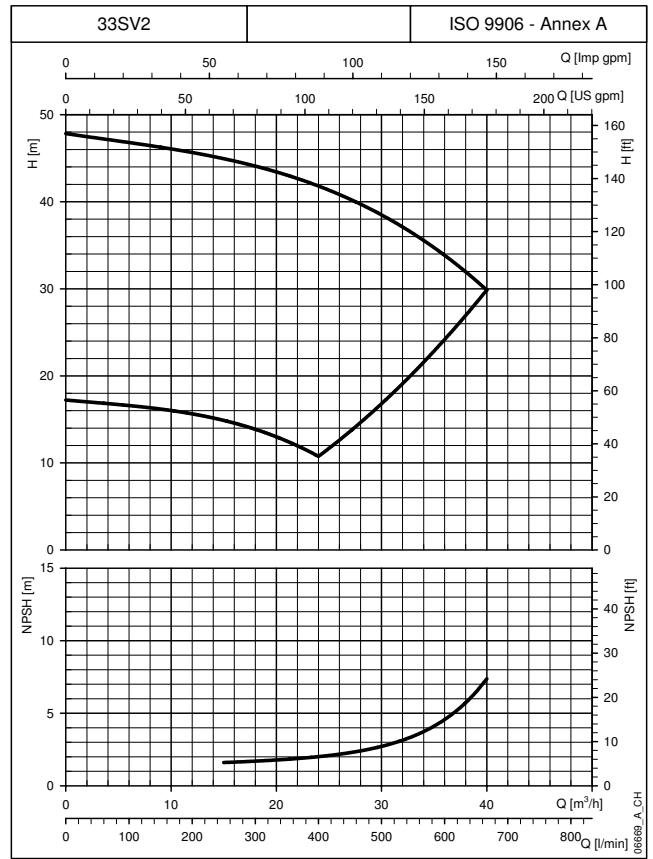
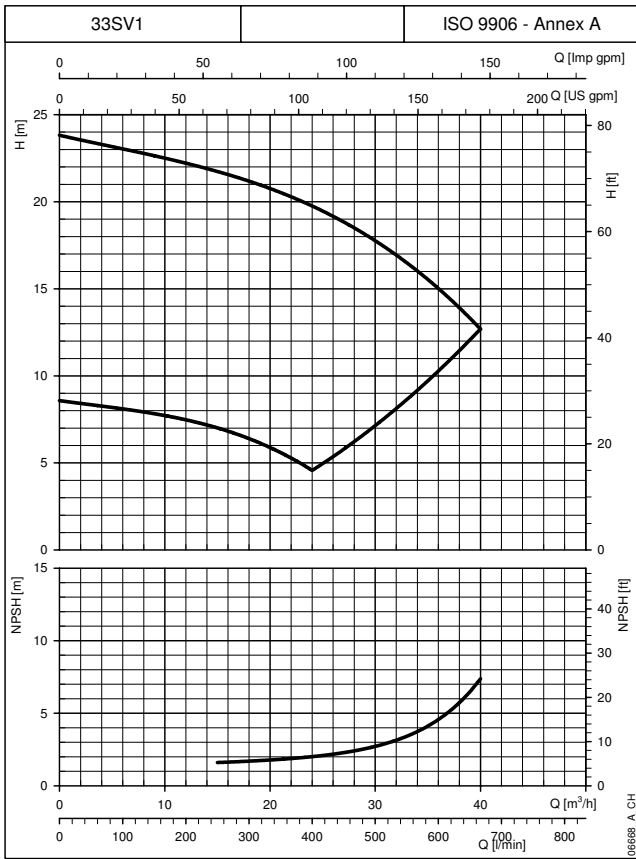

The curves show the performance with one pump running to the minimum and maximum speed.
These performances are valid for liquids with density $\rho = 1.0 \text{ Kg/dm}^3$ and kinematic viscosity $\nu = 1 \text{ mm}^2/\text{s}$.

**33SVH SERIES
OPERATING CHARACTERISTICS AT 30..50 Hz**

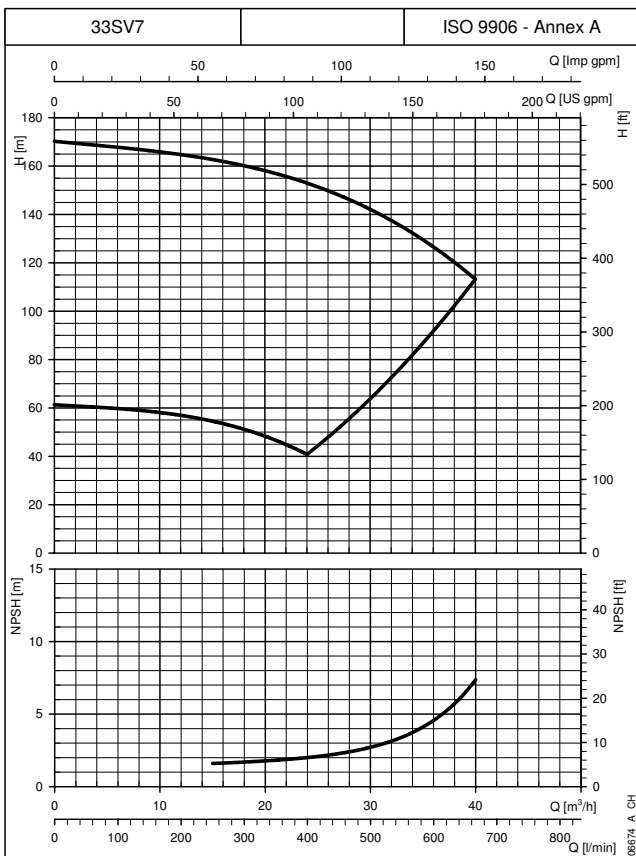
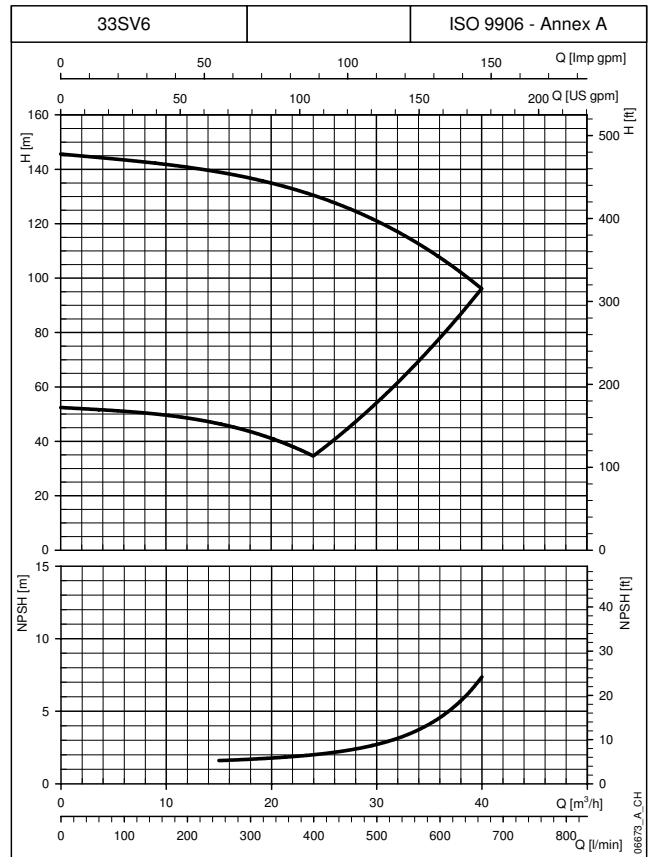
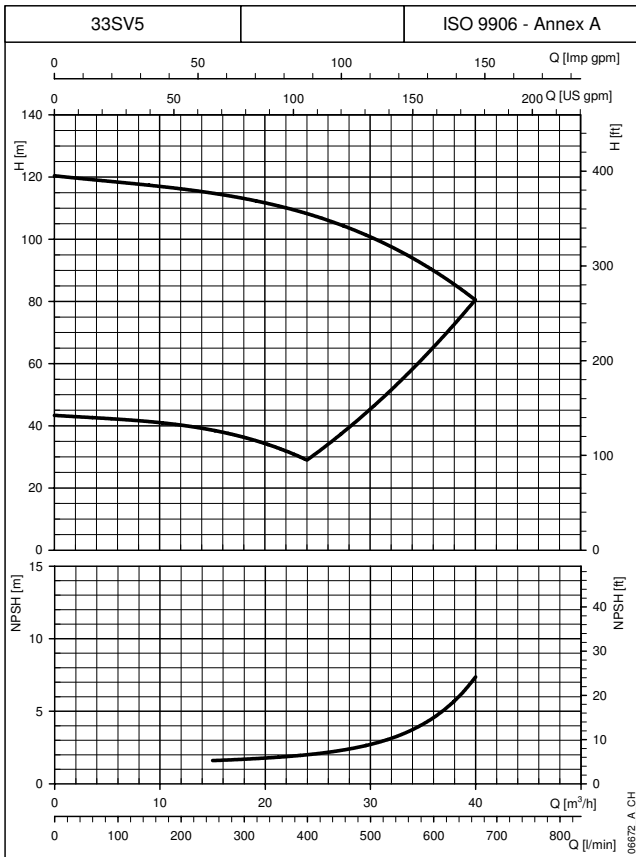

The curves show the performance with one pump running to the minimum and maximum speed.
These performances are valid for liquids with density $\rho = 1.0 \text{ Kg/dm}^3$ and kinematic viscosity $\nu = 1 \text{ mm}^2/\text{s}$.

**e-SVH
HYDROVAR®**

**46SVH SERIES
OPERATING CHARACTERISTICS AT 30..50 Hz**

**e-SVH
HYDROVAR®**

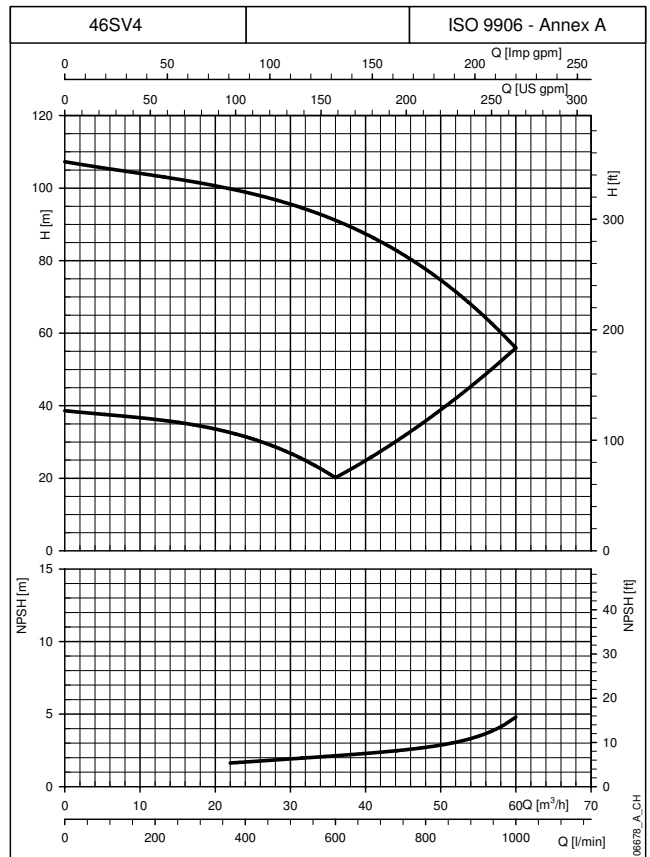
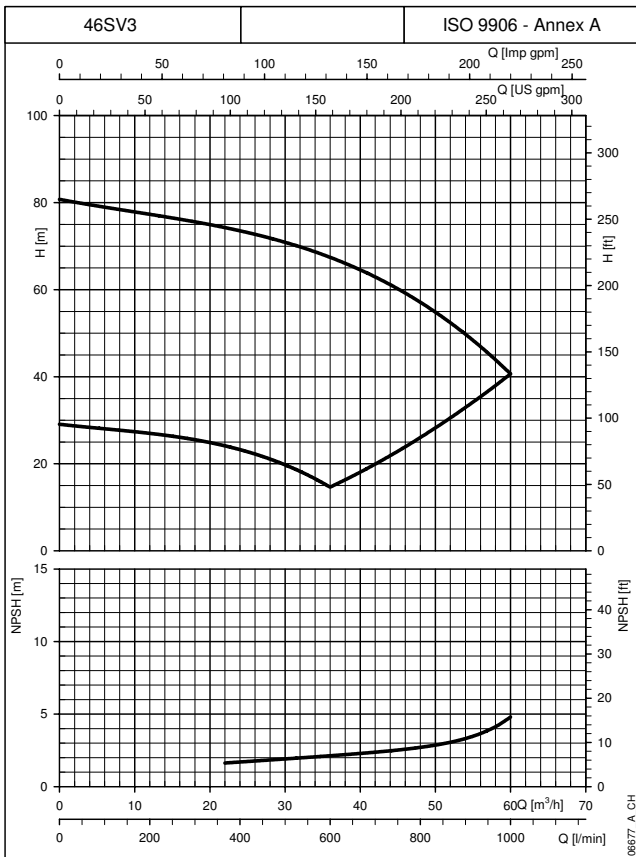
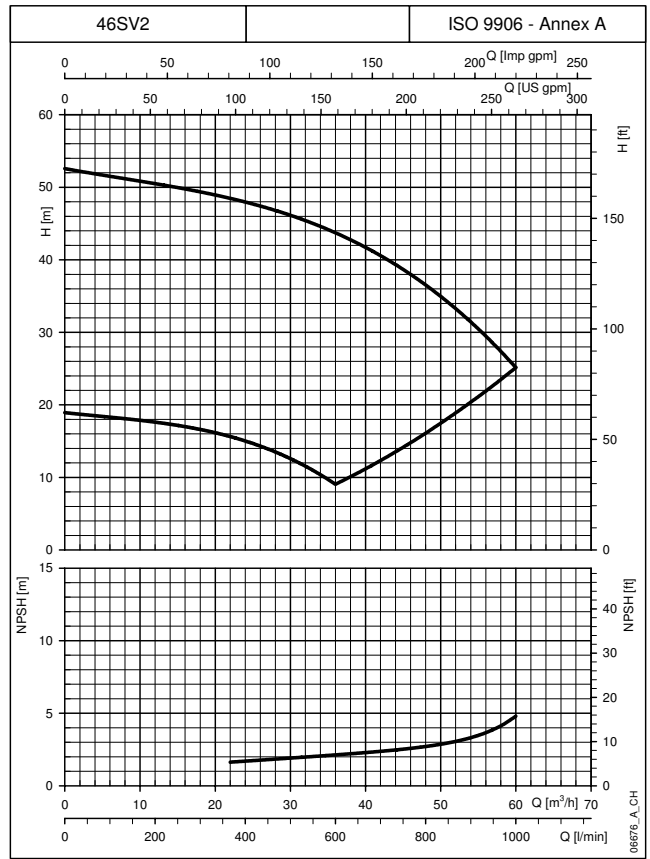
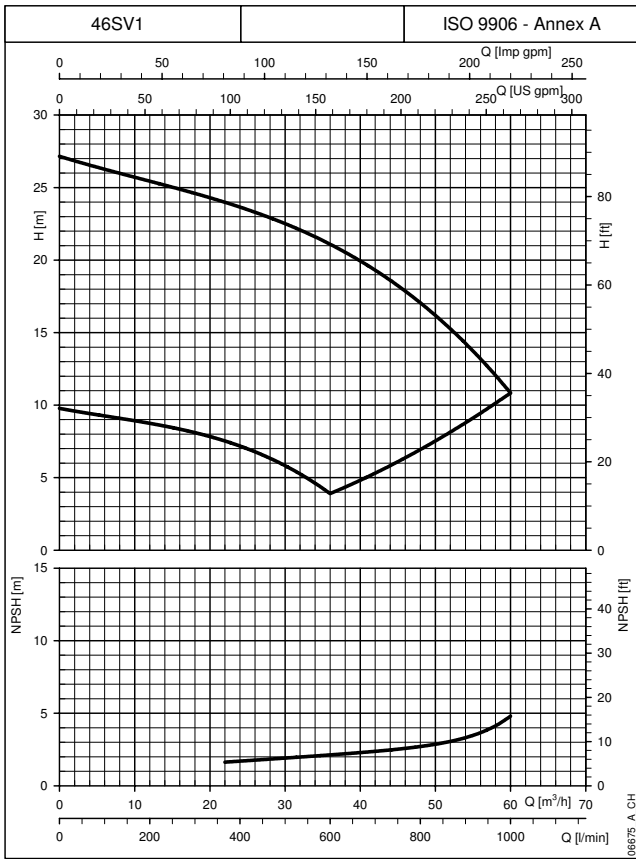

The curves show the performance with one pump running to the minimum and maximum speed.
These performances are valid for liquids with density $\rho = 1.0 \text{ Kg/dm}^3$ and kinematic viscosity $\nu = 1 \text{ mm}^2/\text{s}$.

**46SVH SERIES
OPERATING CHARACTERISTICS AT 30..50 Hz**

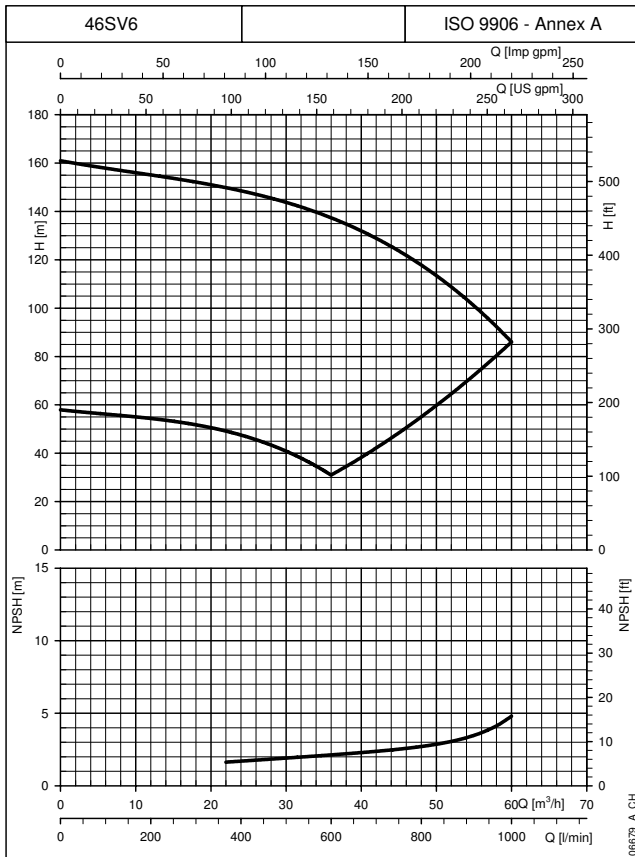

The curves show the performance with one pump running to the minimum and maximum speed.
These performances are valid for liquids with density $\rho = 1.0 \text{ Kg/dm}^3$ and kinematic viscosity $\nu = 1 \text{ mm}^2/\text{s}$.



66SVH SERIES
OPERATING CHARACTERISTICS AT 30..50 Hz

e-SVH
HYDROVAR®

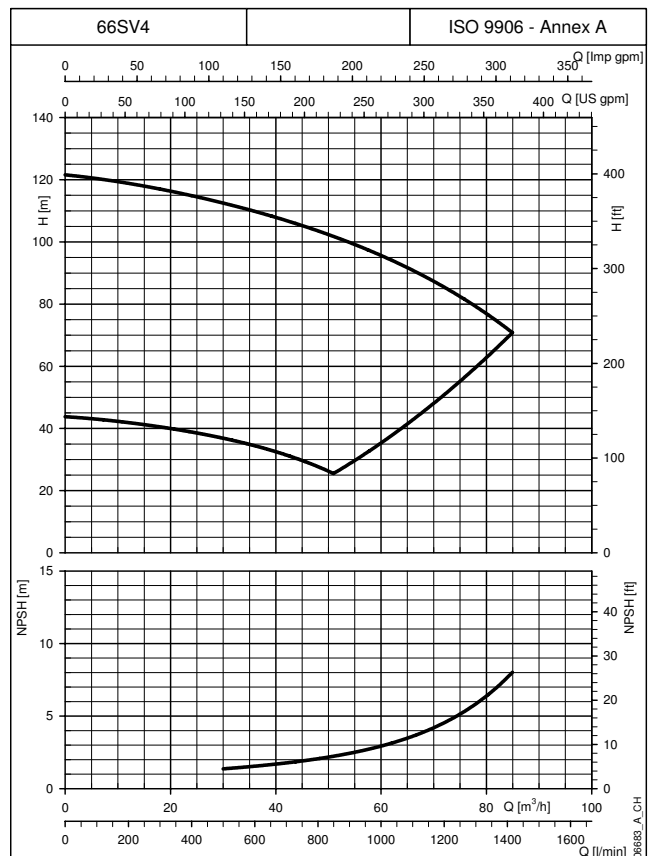
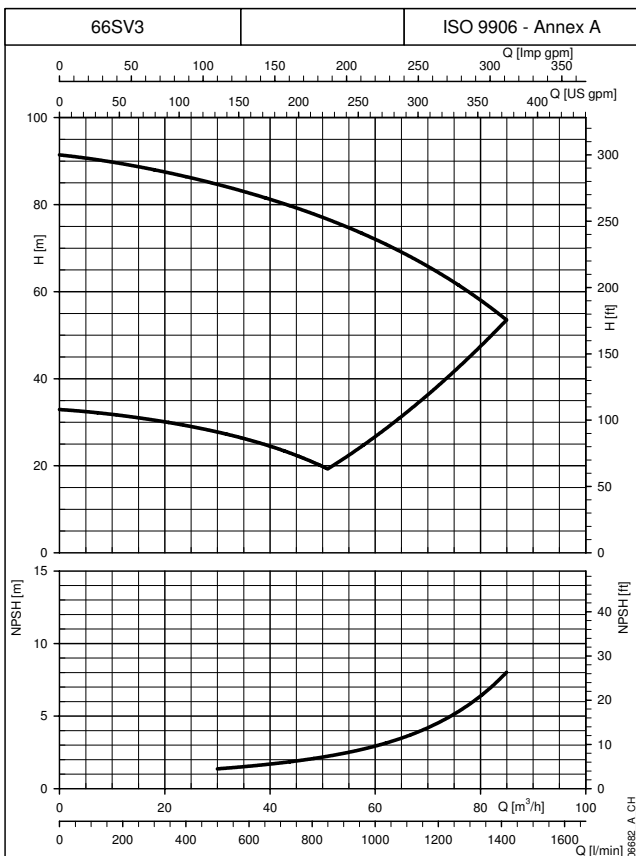
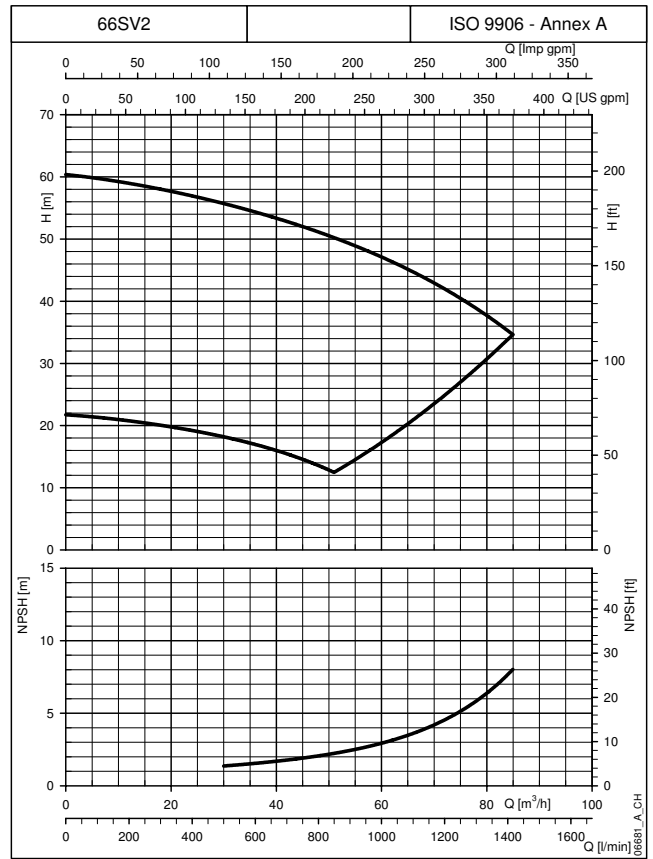
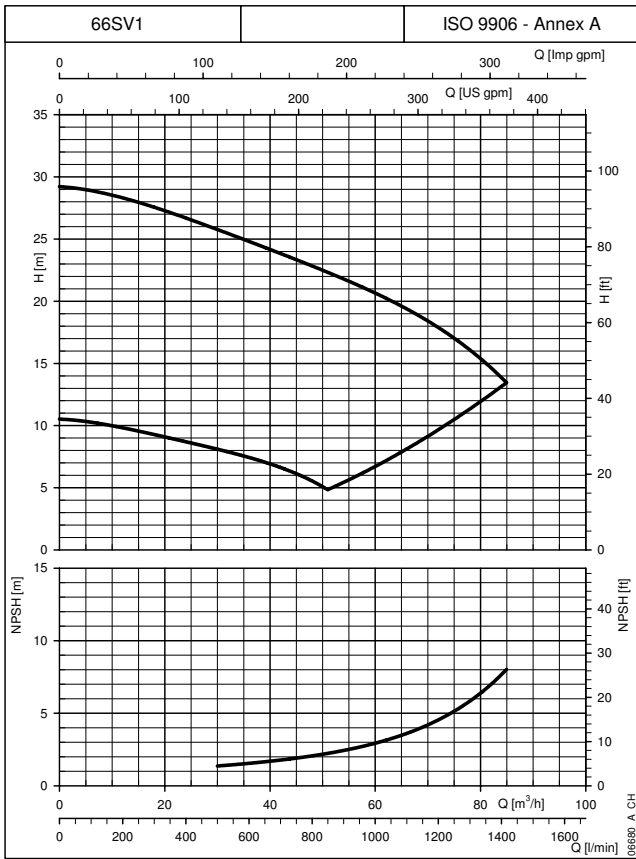

The curves show the performance with one pump running to the minimum and maximum speed.
These performances are valid for liquids with density $\rho = 1.0 \text{ Kg/dm}^3$ and kinematic viscosity $\nu = 1 \text{ mm}^2/\text{s}$.

**92SVH SERIES
OPERATING CHARACTERISTICS AT 30..50 Hz**

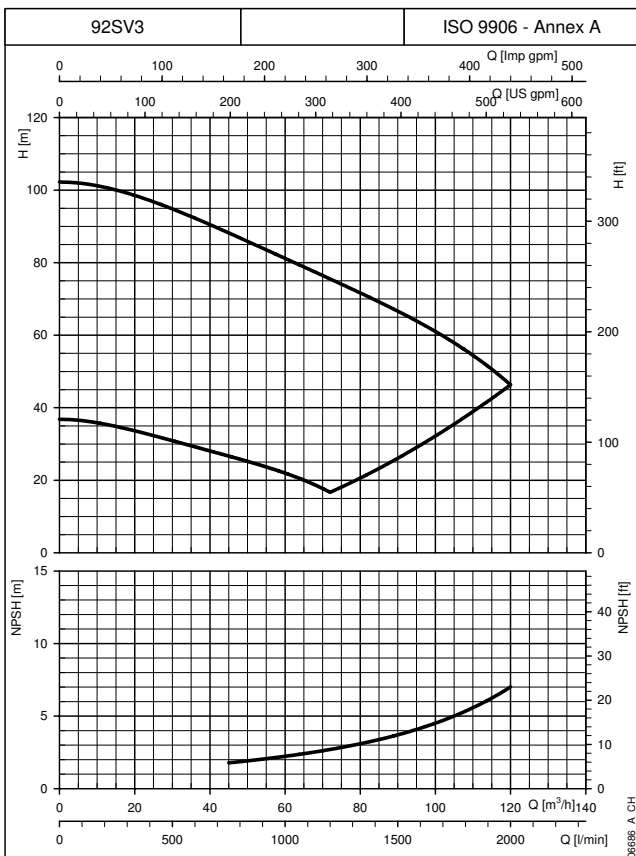
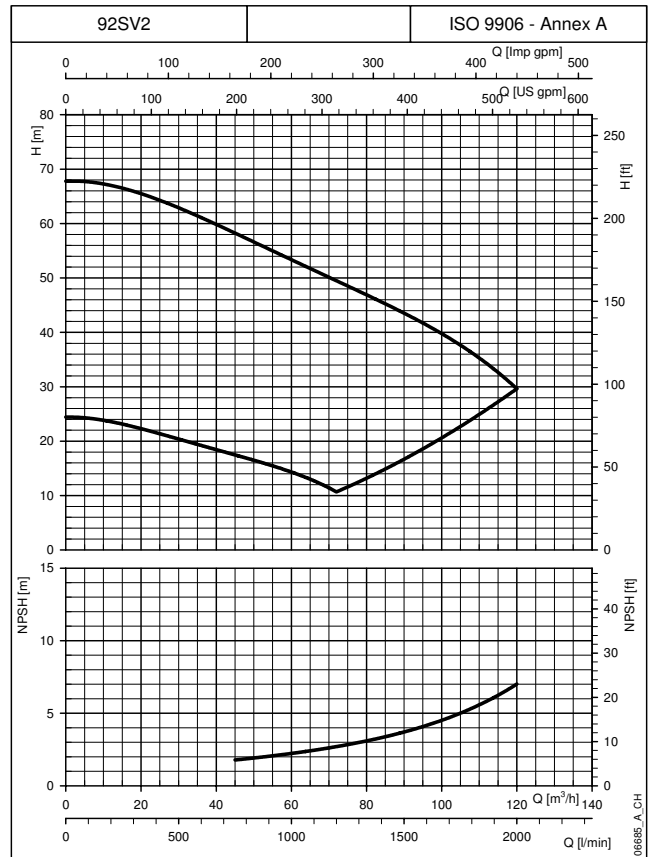
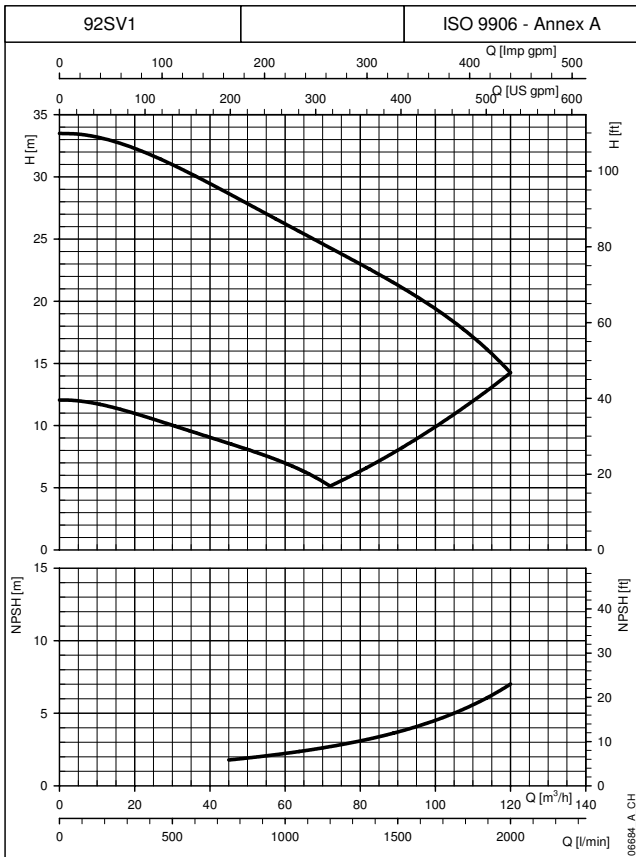

The curves show the performance with one pump running to the minimum and maximum speed.
These performances are valid for liquids with density $\rho = 1.0 \text{ Kg/dm}^3$ and kinematic viscosity $\nu = 1 \text{ mm}^2/\text{s}$.

**e-SVH
HYDROVAR®**

4-POLE VERSIONS (50/60 Hz)

**4-POLE
(50/60 Hz)**

e-SV™ SERIE - 4-POLE VERSION 50/60 Hz

Background and context

In the building services market, reducing the level of noise of the pumping equipment is one of the main goals of architects and facilities managers to bring more comfort to our life. In water boosting systems or in cooling and heating installations, often architects and contractors are looking at quiet operational systems. Therefore Lowara has developed the e-SV™ series with 4 pole versions: a pump which delivers a quiet and reliable solution to the most noise sensitive applications.

Benefits of e-SV™ 4 pole

Low level of noise: e-SV™ 4 pole, by reducing the speed of the pump by 50% allows delivering very quiet operation.

Wide range of performances: e-SV™ 4 pole is available from 1SV to 125SV, from 0,25 kW to 15 kW. e-SV™ 4 pole keeps the same level of efficiency of the standard e-SV™ series.

Increased performance with Hydrovar®: e-SV™ 4 pole combined with Hydrovar®, the variable speed driver developed by Lowara, allows an additional reduction of the noise of the pumping system. Hydrovar®, by smoothing the ramping up and down of the pump, reduces the speed of the water in the piping and as a consequence the noise made by the full installation.

Code identification

e-SV™ 4 pole version is identified with a "4" in the product codification of the whole e-SV™ range.

Example: 3SV11F002**4**T

4 = 4 pole version.



Special features / product benefits

- **Hard material intermediate bush bearing** (Tungsten Carbide) to improve life and ability to withstand heavy duty application on all sizes.
- **IE2 standard motors**, 3-phase, 4-pole from 0,75 kW to 15 kW.
- **Hydrovar® drive available on all models to allow e-SV™ 4 pole into an intelligent, variable speed system.** Ideal for single pumping solution or multiple pumping set solution (up to 8 pumps).
- **Easy-to-replace standard mechanical seal** (EN12756) on all models from 5.5 kW for easy maintenance **without removing the motor.**
- **i-Alert** device to reduce life cycle costs by increasing Mean time between Failures (MTBF).

Special configurations

e-SV™ 4 pole offers the same range of configuration of the standard e-SV™ series.

- Material execution. See Material section.
- Mechanical seal and rubbers options. See Mechanical seal and rubber section.
- Motors options and configuration. See Motor section.
- Hydrovar® drive fitted. See e-SVH – Hydrovar® fitted section.

e-SV™ SERIES

HYDRAULIC PERFORMANCE RANGE AT 50 Hz, 4-POLE

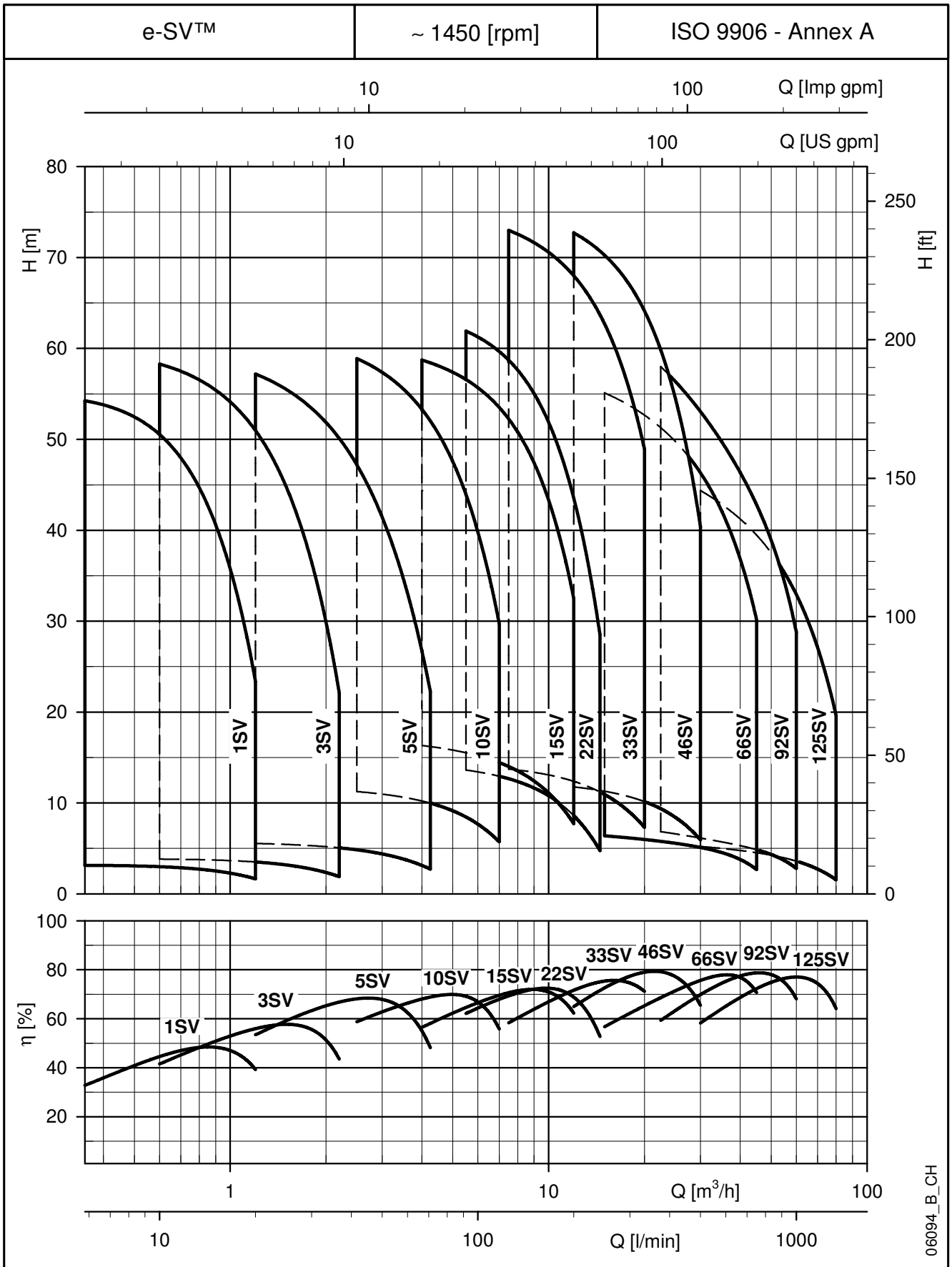

1, 3, 5, 10, 15, 22SV SERIES HYDRAULIC PERFORMANCE TABLE AT 50 Hz, 4-POLE

PUMP TYPE	RATED POWER		Q = DELIVERY													
	kW	HP	l/min 0	5,84	10	12,5	15	18	20	22	25	30	36	50	60	70,83
			m³/h 0	0,4	0,6	0,8	0,9	1,1	1,2	1,3	1,5	1,8	2,2	3,0	3,6	4,2
H = TOTAL HEAD IN METRES OF COLUMN OF WATER																
1SV02..4	0,25	0,34	3,1	3,1	3,0	2,8	2,5	2,1	1,7							
1SV05..4	0,25	0,34	7,7	7,8	7,4	6,9	6,2	5,0	4,0							
1SV08..4	0,25	0,34	12,2	12,4	11,7	10,9	9,8	7,9	6,3							
1SV11..4	0,25	0,34	16,7	16,9	16,0	14,9	13,3	10,7	8,5							
1SV15..4	0,25	0,34	22,6	22,9	21,6	20,0	17,8	14,3	11,3							
1SV19..4	0,25	0,34	28,8	29,4	27,7	25,6	22,8	18,2	14,4							
1SV22..4	0,25	0,34	33,2	33,8	31,7	29,3	26,0	20,6	16,2							
1SV27..4	0,25	0,34	40,1	40,4	38,0	35,2	31,1	24,3	18,6							
1SV30..4	0,25	0,34	44,4	44,6	41,9	38,6	34,0	26,5	20,1							
1SV34..4	0,25	0,34	50,0	50,2	46,9	43,1	37,9	29,3	22,1							
1SV37..4	0,25	0,34	54,2	54,2	50,5	46,4	40,6	31,2	23,4							
3SV02..4	0,25	0,34	3,8		3,8	3,8	3,7	3,6	3,5	3,4	3,2	2,7	2,0			
3SV05..4	0,25	0,34	9,5		9,5	9,4	9,2	8,9	8,6	8,3	7,8	6,7	4,8			
3SV08..4	0,25	0,34	15,1		14,9	14,7	14,4	14,0	13,6	13,1	12,2	10,4	7,4			
3SV11..4	0,25	0,34	20,6		20,3	20,0	19,6	18,9	18,3	17,7	16,5	13,9	9,8			
3SV14..4	0,25	0,34	26,1		25,8	25,3	24,8	23,9	23,1	22,2	20,7	17,3	12,0			
3SV19..4	0,25	0,34	33,3		32,6	32,0	31,3	30,0	29,0	27,9	25,8	21,5	14,5			
3SV23..4	0,25	0,34	42,2		40,9	40,1	39,0	37,4	36,0	34,5	31,8	26,1	17,2			
3SV27..4	0,37	0,5	49,7		48,5	47,5	46,3	44,4	42,9	41,1	38,0	31,4	21,0			
3SV33..4	0,37	0,5	60,2		58,3	57,0	55,4	53,0	51,0	48,7	44,8	36,5	23,7			
5SV03..4	0,25	0,34	5,7						6	6	5	5	5,1	4,4	3,7	2,7
5SV06..4	0,25	0,34	11,3						10,9	10,8	10,7	10,4	9,9	8,5	7,0	5,0
5SV09..4	0,25	0,34	16,8						16,1	16,0	15,7	15,3	14,6	12,3	10,1	7,1
5SV12..4	0,25	0,34	22,2						21,1	20,9	20,5	19,8	18,8	15,6	12,6	8,7
5SV15..4	0,37	0,5	27,5						25,9	25,6	25,2	24,2	22,9	18,8	15,0	10,1
5SV18..4	0,37	0,5	33,1						31,3	31,0	30,4	29,3	27,8	22,9	18,4	12,5
5SV21..4	0,37	0,5	38,4						36,1	35,7	35,0	33,6	31,7	26,0	20,7	13,7
5SV25..4	0,55	0,75	45,3						42,2	41,6	40,8	39,1	36,7	29,7	23,3	15,1
5SV28..4	0,55	0,75	51,7						49,1	48,6	47,8	46,1	43,7	36,2	29,2	20,0
5SV33..4	0,75	1	60,5						57,2	56,6	55,5	53,4	50,5	41,4	33,1	22,3

Performances in compliance with ISO 9906 - Annex A.

1-5sv-4p50-en_a_th

PUMP TYPE	RATED POWER		Q = DELIVERY													
	kW	HP	l/min 0	41,7	50	66,67	85	91,7	116,6	135	165	175	200	215	230	241,6
			m³/h 0	2,5	3,0	4,0	5,1	5,5	7,0	8,1	9,9	10,5	12,0	12,9	13,8	14,5
H = TOTAL HEAD IN METRES OF COLUMN OF WATER																
10SV03..4	0,55	0,75	9,0	8,4	8,2	7,7	6,7	6,3	4,3							
10SV04..4	0,55	0,75	12,0	11,2	11,0	10,2	9,0	8,5	5,7							
10SV06..4	0,55	0,75	17,9	16,7	16,2	15,1	13,3	12,5	8,5							
10SV08..4	0,55	0,75	23,6	21,9	21,3	19,7	17,2	16,1	10,7							
10SV10..4	0,55	1	28,9	26,6	25,8	23,7	20,6	19,3	12,7							
10SV13..4	0,75	1	37,9	34,4	33,3	30,4	26,0	24,1	15,2							
10SV15..4	0,75	1,0	44,1	40,4	39,1	35,9	31,0	28,9	18,6							
10SV17..4	1,1	1,5	49,6	45,0	43,5	39,7	34,1	31,6	19,7							
10SV19..4	1,1	1,5	55,2	49,7	47,9	43,6	37,2	34,4	21,1							
10SV21..4	1,1	1,5	62,8	58,9	57,4	53,3	46,9	43,9	29,7							
15SV03..4	0,55	0,75	10,7			10,0	9,7	9,5	8,9	8,3	7,0	6,5	4,9			
15SV05..4	0,55	0,75	17,8			16,3	15,8	15,5	14,4	13,4	11,2	10,4	7,7			
15SV07..4	0,75	1,00	24,6			22,2	21,3	21,0	19,5	18,0	15,0	13,7	10,0			
15SV09..4	1,1	1,50	32,8			30,8	29,9	29,6	27,8	26,1	22,4	20,9	16,4			
15SV11..4	1,1	2	40,1			37,2	36,2	35,7	33,6	31,5	27,1	25,2	19,7			
15SV13..4	1,5	2	47,6			44,5	43,3	42,7	40,3	38,0	32,7	30,6	24,1			
15SV15..4	1,5	2,0	54,8			51,1	49,7	49,1	46,3	43,6	37,5	35,0	27,4			
15SV17..4	2,2	3	62,5			58,7	57,2	56,6	53,5	50,5	43,8	41,0	32,5			
22SV04..4	0,55	0,75	14,9						13,6	12,9	12,3	10,9	10,3	8,6	7,4	6,0 4,8
22SV06..4	1,1	1,5	22,6						20,8	19,8	18,9	16,9	16,0	13,6	11,9	9,9 8,2
22SV08..4	1,1	1,5	30,8						29,0	27,9	26,8	24,3	23,3	20,2	17,9	15,4 13,1
22SV10..4	1,5	2	38,6						36,5	35,2	33,8	30,8	29,5	25,7	22,9	19,7 17,0
22SV12..4	2,2	3	46,0						43,4	41,8	40,2	36,5	35,0	30,3	26,9	23,0 19,7
22SV14..4	2,2	3	53,9						51,4	49,6	47,8	43,6	41,8	36,5	32,6	28,1 24,2
22SV17..4	3	4	65,3						61,9	59,7	57,4	52,2	50,1	43,5	38,8	33,3 28,5

Performances in compliance with ISO 9906 - Annex A.

10-22sv-4p50-en_a_th

33, 46, 66, 92, 125SV SERIES HYDRAULIC PERFORMANCE TABLE AT 50 Hz, 4-POLE

PUMP TYPE	RATED POWER		Q = DELIVERY															
			l/min 0	125	150	200	250	300	333	375	450	500	600	700	750	800	900	1000
			m ³ /h 0	7,5	9	12	15	18	20	22,5	27	30	36	42	45	48	54	60
kW		HP	H = TOTAL HEAD METRES COLUMN OF WATER															
33SV3/2A..4	1,1	1,5	14,4	13,7	13,4	12,4	10,9	9	7,3									
33SV4/1A..4	1,1	1,5	21,8	20,4	19,9	18,7	16,9	14,4	12,3									
33SV5..4	1,5	2	29,4	27,5	26,9	25,5	23,4	20,4	17,9									
33SV6..4	2,2	3	35,9	33,8	33,2	31,5	29	25,5	22,5									
33SV7..4	2,2	3	41,6	39,1	38,3	36,2	33,2	29,1	25,6									
33SV8..4	3	4	47,9	45,2	44,3	42	38,8	34,2	31,3									
33SV9..4	3	4	53,3	50,2	49,2	46,7	43	37,9	33,4									
33SV10..4	3	4	59	55,4	54	51	47	41,5	36,5									
33SV11..4	4	5,5	65,7	62,2	61	58	54	48	42,3									
33SV12..4	4	5,5	71,5	67,6	66	63	58	52	45,7									
33SV13..4	4	5,5	77,2	73	72	68	63	55	49									
46SV2..4	1,1	1,5	13			11,8	11,3	10,7	10,1	9,4	7,5	5,9						
46SV3..4	1,5	2	19,8			17,8	17,1	16,2	15,4	14,2	11,5	9,2						
46SV4..4	2,2	3	26,3			24	23,1	21,9	20,9	19,4	15,8	12,7						
46SV5..4	2,2	3	32,6			29,6	28,5	27	25,8	23,9	19,4	15,5						
46SV6..4	3	4	39,3			35,9	34,6	32,9	31,5	29,3	24,1	19,5						
46SV7..4	3	4	45,5			41,5	40	37,9	36,2	33,6	27,4	22						
46SV8..4	4	5,5	52,5			48,3	46,6	44,4	42,5	39,6	32,6	26,5						
46SV9..4	4	5,5	58,9			53,9	52	50	47,4	44,1	36,2	29,2						
46SV10..4	5,5	7,5	66,2			61	59	56	54	50,5	42	34,5						
46SV11..4	5,5	7,5	72,6			66,9	65	62	59	55,2	46	37,6						
46SV12..4	5,5	7,5	78,9			72,7	70	67	64	59,8	50	40,4						
66SV1..4	1,1	1,5	7,3			6,4	6,1	6	5,8	5,4	5,1	4,4	3,4	2,7				
66SV2..4	1,5	2	14,8			13,5	13,1	12,9	12,5	11,8	11,2	9,9	8,2	7,2				
66SV3..4	2,2	3	22,3			20,3	19,7	19,3	18,8	17,7	16,9	14,9	12,3	10,7				
66SV4..4	3	4	29,7			27,1	26,4	25,8	25,1	23,7	22,6	20	16,6	14,5				
66SV5..4	4	5,5	37,5			34,4	33,5	32,9	32	30,3	28,9	25,7	21,4	18,8				
66SV6..4	4	5,5	44,7			40,9	39,8	39	38	36	34,1	30,2	25,1	21,9				
66SV7..4	5,5	7,5	52,8			48,5	47,3	46	45	43	41	36	30,5	26,8				
66SV8..4	5,5	7,5	60,1			55,1	53,7	53	51	49	46	41	34,3	30,2				
92SV1..4	1,1	1,5	8,3						7	6,4	6,1	5,6	5,1	4,9	4,6	3,8	2,8	
92SV2..4	2,2	3	16,3						14,3	13,6	13,1	12,1	11,1	10,5	10	8,6	7	
92SV3..4	3	4	24,4						21,3	20,1	19,4	17,8	16,3	15,5	14,6	12,7	10,2	
92SV4..4	4	5,5	32,9						28,9	27,4	26,4	24,4	22,4	21,3	20,2	17,5	14,3	
92SV5..4	5,5	7,5	41,6						36,7	34,9	33,6	31,1	28,6	27,2	25,8	22,6	18,6	
92SV6..4	5,5	7,5	49,5						43,6	41	40	37	34	32,2	30,5	26,6	21,7	
92SV7..4	7,5	10	58						51,2	49	47	43	40	38	35,9	31,4	25,7	
92SV8..4	7,5	10	65,9						58	55	53	49	45	43	40,5	35,3	28,8	

Performances in compliance with ISO 9906 - Annex A.

33-92sv-4p50-en_a_th

PUMP TYPE	RATED POWER		Q = DELIVERY													
			l/min 0	250	300	375	450	500	600	708	850	950	1000	1075	1150	1333
			m ³ /h 0	15,0	18,0	22,5	27,0	30,0	36,0	42,5	51,0	57,0	60,0	64,5	69,0	80,0
kW		HP	H = TOTAL HEAD IN METRES OF COLUMN OF WATER													
125SV1..4	1,1	1,5	6,9					5,2	5,0	4,7	4,2	3,8	3,6	3,2	2,8	1,5
125SV2..4	2,2	3	13,5					11,1	10,6	10,1	9,3	8,6	8,2	7,6	6,9	4,9
125SV3/3B..4	2,2	3	17,5					14,1	13,4	12,6	11,2	10,1	9,5	8,4	7,2	3,6
125SV4/4B..4	3	4	23,3					18,8	17,9	16,7	15,0	13,5	12,6	11,2	9,6	4,9
125SV5/5A..4	4	5,5	31,4					25,6	24,4	23,0	20,9	19,2	18,2	16,5	14,7	9,2
125SV6..4	5,5	7,5	40,4					33,3	31,9	30,3	27,8	25,8	24,7	22,8	20,8	14,7
125SV7..4	7,5	10	47,1					38,8	37,2	35,3	32,5	30,1	28,8	26,7	24,2	17,2
125SV8..4	7,5	10	53,8					44,4	42,5	40,4	37,1	34,4	32,9	30,5	27,7	19,6

Performances in compliance with ISO 9906 - Annex A.

125sv-4p50-en_a_th

**4-POLE
(50 Hz)**

1SV SERIES DIMENSIONS AND WEIGHTS AT 50 Hz, 4-POLE

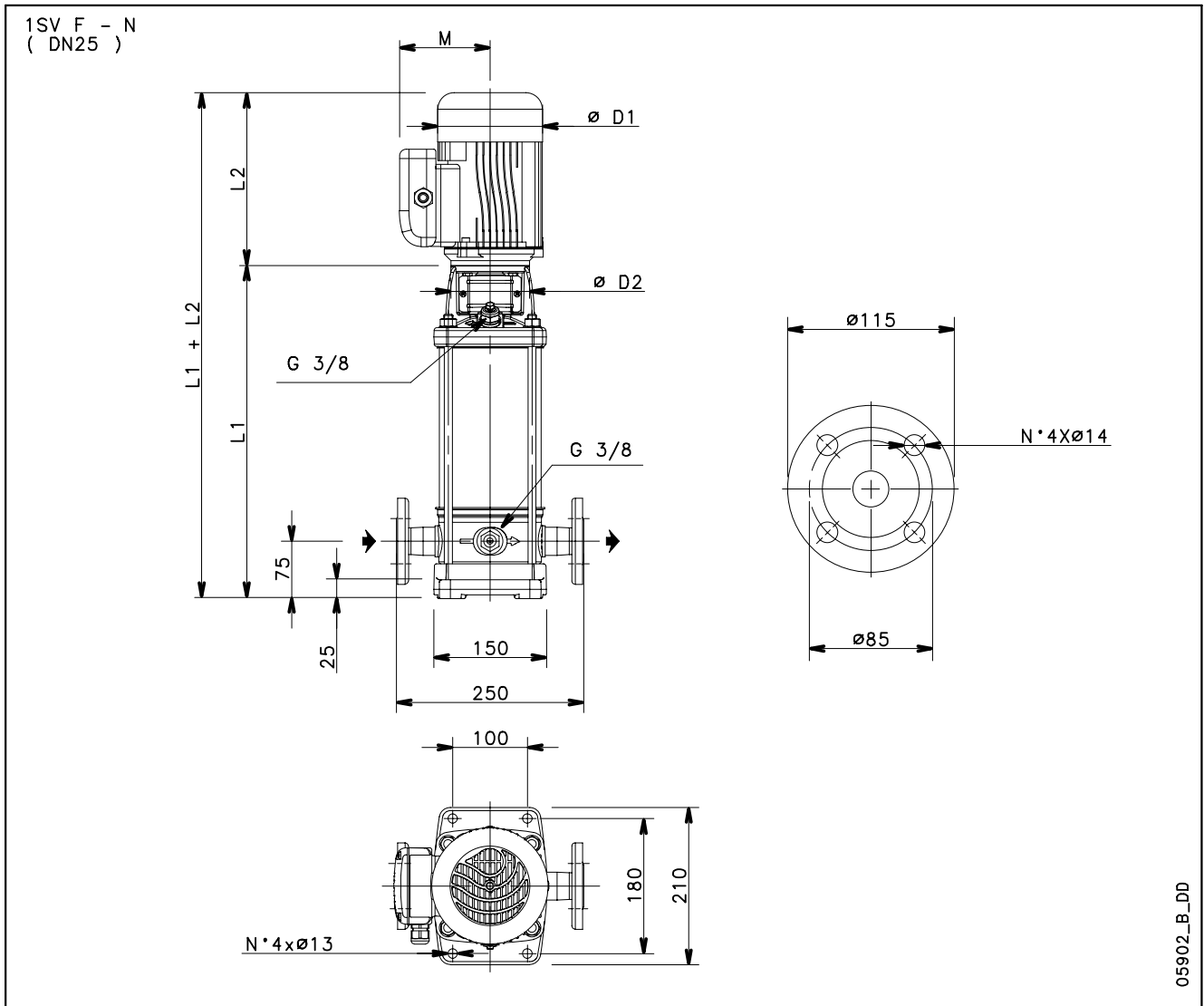

PUMP TYPE	MOTOR		DIMENSIONS (mm)					WEIGHT kg	
	kW	SIZE	L1	L2	D1	D2	M	PUMP	ELECTRIC PUMP
1SV02..4..	0,25	71	278	231	140	105	121	8,3	15,2
1SV05..4..	0,25	71	318	231	140	105	121	9,4	16,2
1SV08..4..	0,25	71	378	231	140	105	121	10,6	17,4
1SV11..4..	0,25	71	438	231	140	105	121	11,8	18,6
1SV15..4..	0,25	71	518	231	140	105	121	13,4	20,2
1SV19..4..	0,25	71	598	231	140	105	121	14,9	21,7
1SV22..4..	0,25	71	658	231	140	105	121	16,1	22,9
1SV27..4..	0,25	71	758	231	140	105	121	18,1	24,9
1SV30..4..	0,25	71	818	231	140	105	121	19,3	26,1
1SV34..4..	0,25	71	898	231	140	105	121	20,9	27,7
1SV37..4..	0,25	71	958	231	140	105	121	22,1	28,9

1sv-4p50-en_b_td

4-POLE
(50 Hz)

**1SV SERIES
OPERATING CHARACTERISTICS AT 50 Hz, 4-POLE**

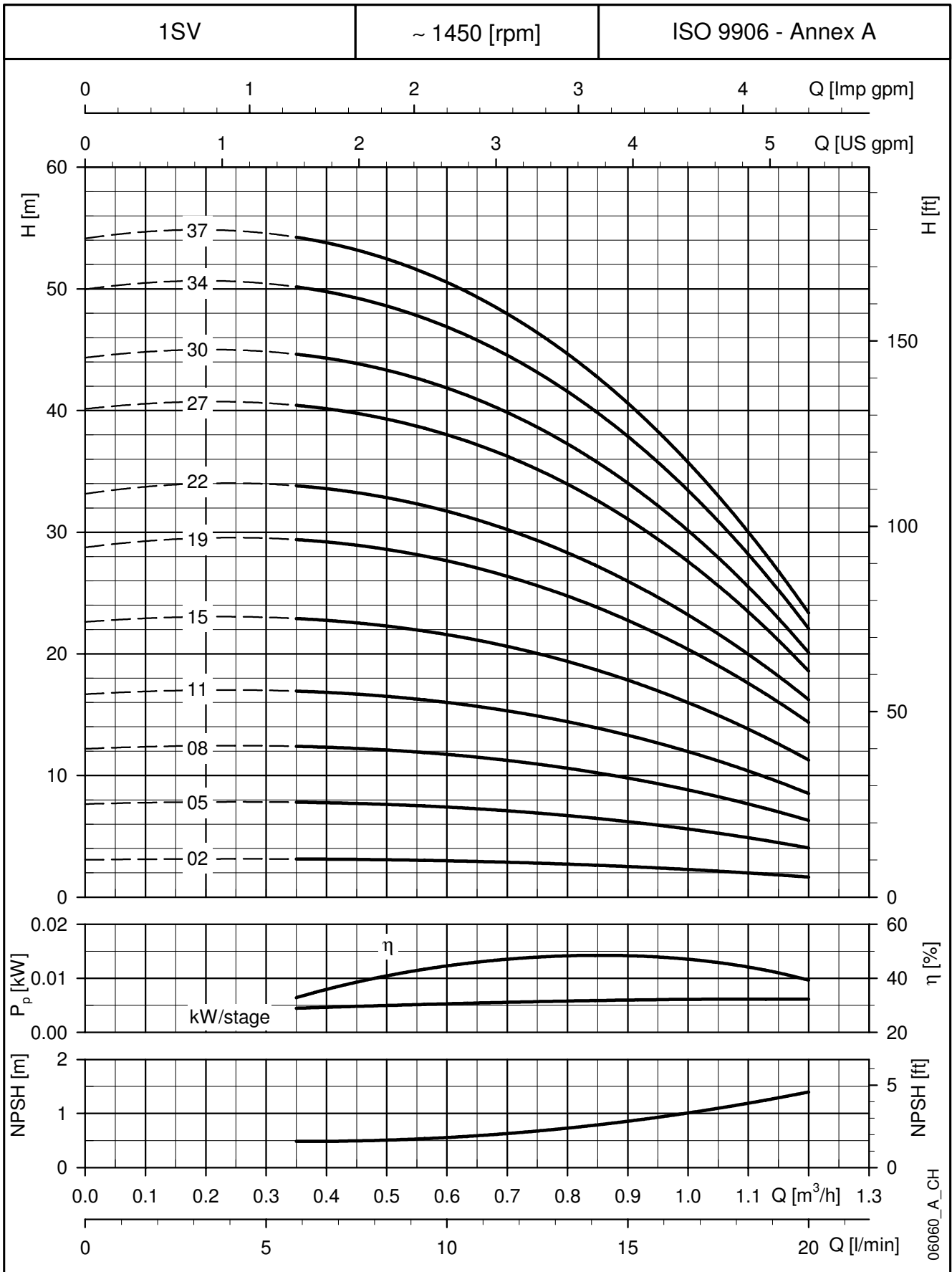

**4-POLE
(50 Hz)**

These performances are valid for liquids with density $\rho = 1.0 \text{ Kg/dm}^3$ and kinematic viscosity $\nu = 1 \text{ mm}^2/\text{sec}$.

3SV SERIES
DIMENSIONS AND WEIGHTS AT 50 Hz, 4-POLE

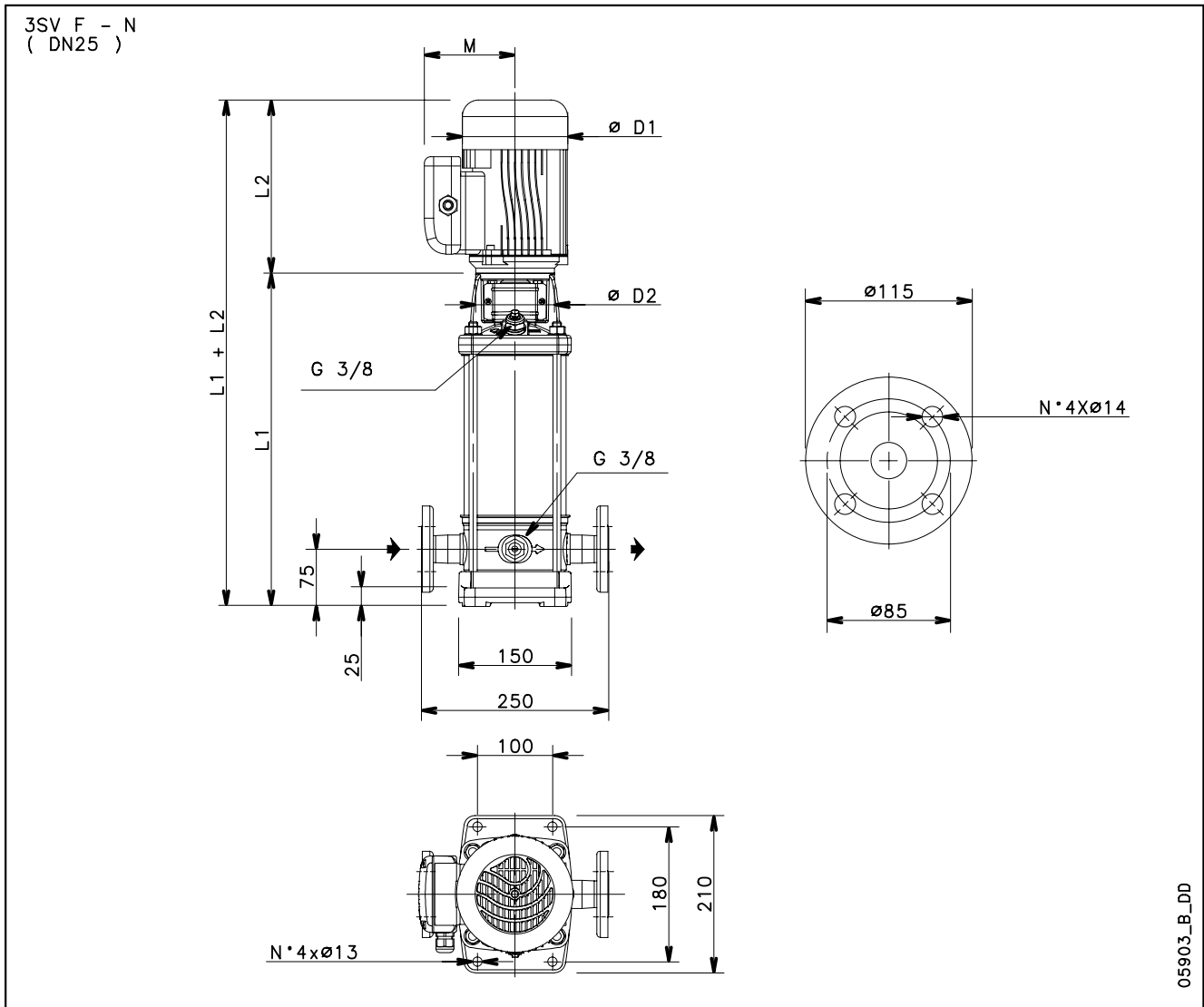

**4-POLE
(50 Hz)**

PUMP TYPE	MOTOR		DIMENSIONS (mm)					WEIGHT kg	
	kW	SIZE	L1	L2	D1	D2	M	PUMP	ELECTRIC PUMP
3SV02..4..	0,25	71	278	231	140	105	121	8	14,9
3SV05..4..	0,25	71	318	231	140	105	121	9,3	16,8
3SV08..4..	0,25	71	378	231	140	105	121	10,5	17,3
3SV11..4..	0,25	71	438	231	140	105	121	11,6	18,4
3SV14..4..	0,25	71	498	231	140	105	121	12,9	19,6
3SV19..4..	0,25	71	598	231	140	105	121	14,9	21,6
3SV23..4..	0,25	71	678	231	140	105	121	16,5	23,2
3SV27..4..	0,37	71	758	231	140	105	121	18	26
3SV33..4..	0,37	71	878	231	140	105	121	20,4	28,4

**3SV SERIES
OPERATING CHARACTERISTICS AT 50 Hz, 4-POLE**

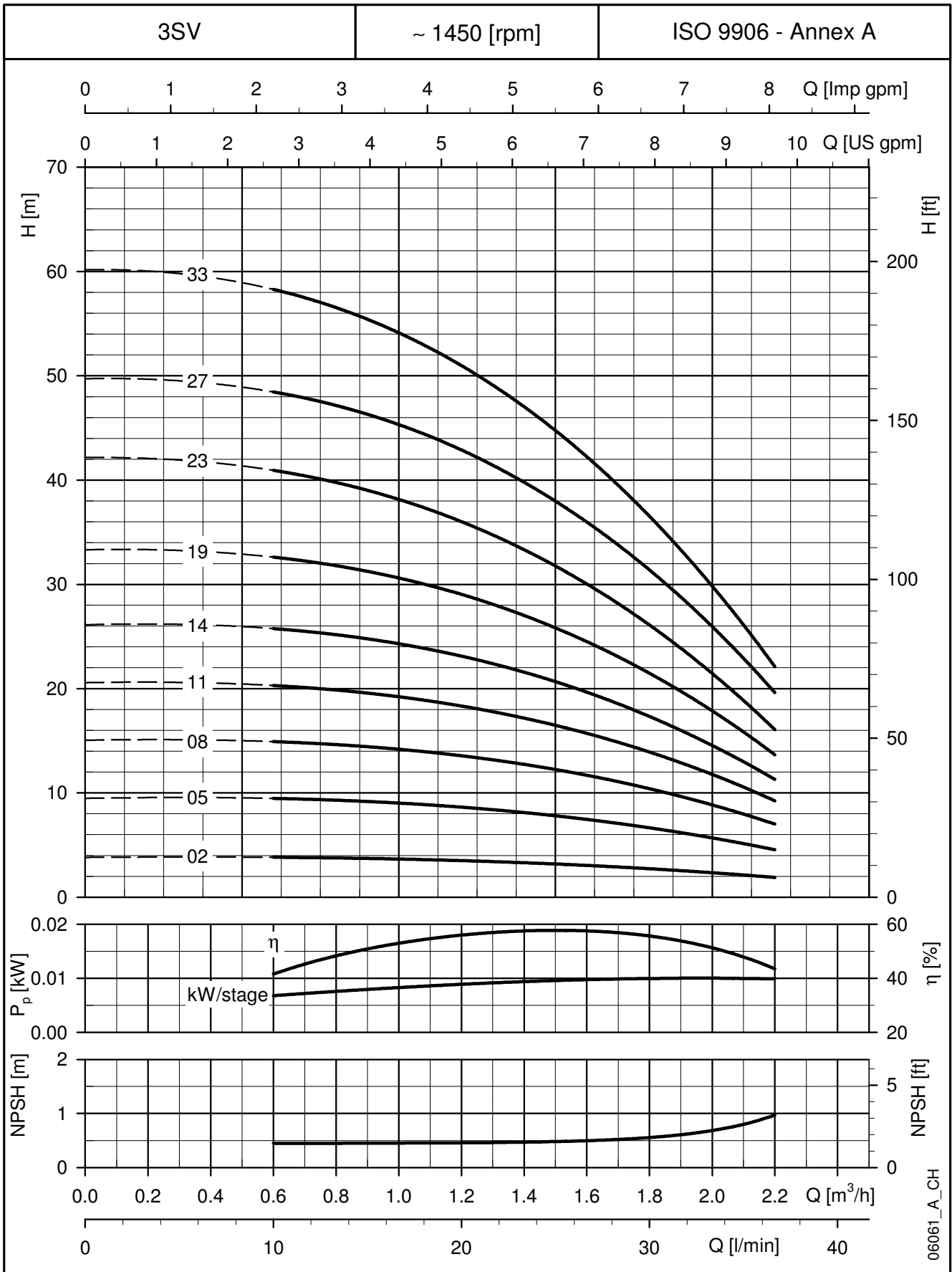

These performances are valid for liquids with density $\rho = 1.0 \text{ Kg/dm}^3$ and kinematic viscosity $\nu = 1 \text{ mm}^2/\text{sec}$.

5SV SERIES

DIMENSIONS AND WEIGHTS AT 50 Hz, 4-POLE

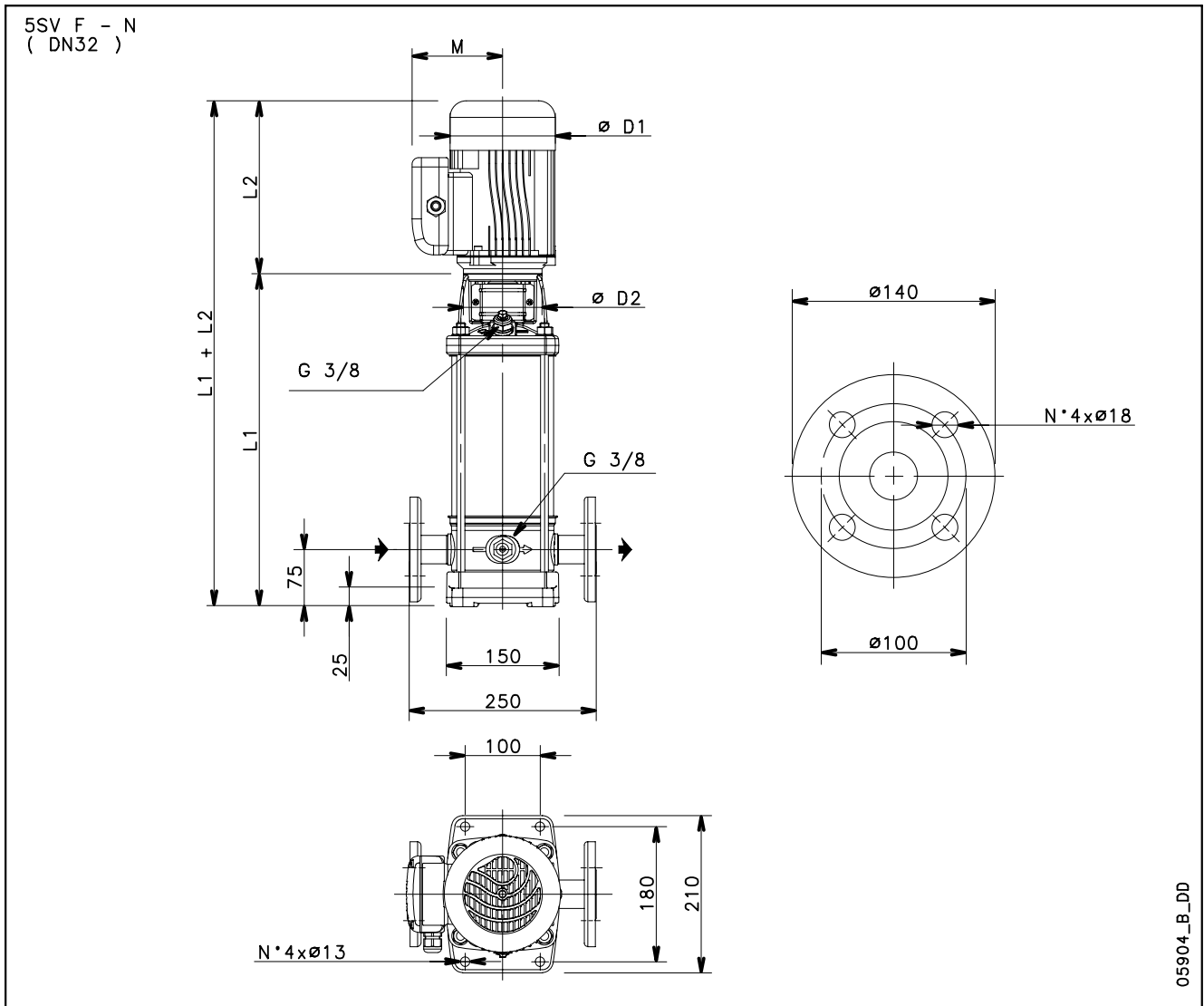

PUMP TYPE	MOTOR		DIMENSIONS (mm)					WEIGHT kg	
	kW	SIZE	L1	L2	D1	D2	M	PUMP	ELECTRIC PUMP
5SV03..4..	0,25	71	293	231	140	105	121	8,9	15,7
5SV06..4..	0,25	71	368	231	140	105	121	10,4	17,2
5SV09..4..	0,25	71	443	231	140	105	121	11,8	18,6
5SV12..4..	0,25	71	518	231	140	105	121	13,2	20
5SV15..4..	0,37	71	593	231	140	105	121	14,6	22,6
5SV18..4..	0,37	71	668	231	140	105	121	16	24
5SV21..4..	0,37	71	743	231	140	105	121	17,5	25,5
5SV25..4..	0,55	80	853	263	155	120	129	20	26,7
5SV28..4..	0,55	80	928	263	155	120	129	21,4	28,1
5SV33..4..	0,75	80	1053	231	159	120	128	23,8	36

5sv-4p50-en_c_td

4-POLE
(50 Hz)

**5SV SERIES
OPERATING CHARACTERISTICS AT 50 Hz, 4-POLE**

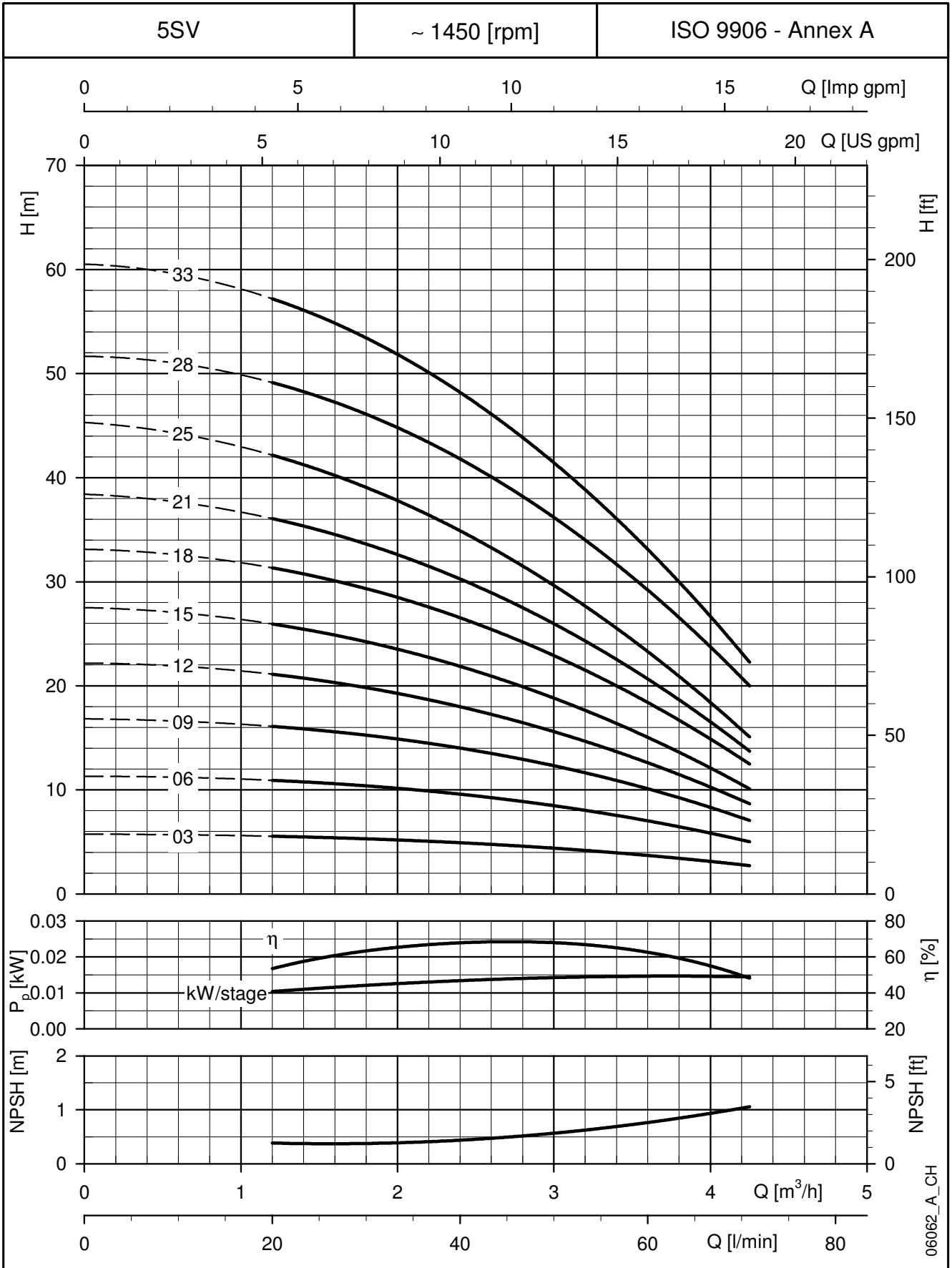

**4-POLE
(50 Hz)**

These performances are valid for liquids with density $\rho = 1.0 \text{ Kg/dm}^3$ and kinematic viscosity $\nu = 1 \text{ mm}^2/\text{sec}$.

10SV SERIES
DIMENSIONS AND WEIGHTS AT 50 Hz, 4-POLE

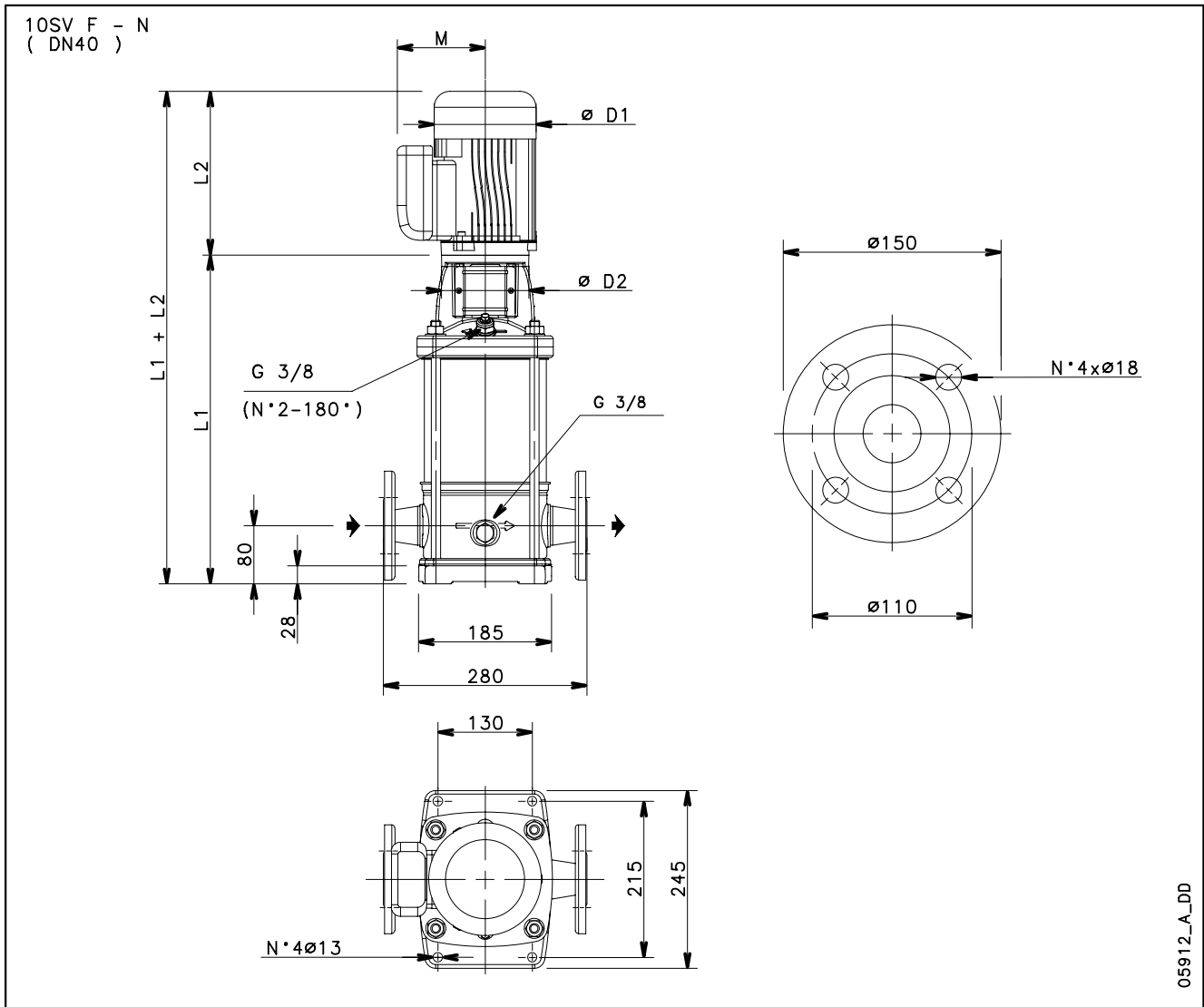

05912_A_DD

4-POLE
(50 Hz)

PUMP TYPE	MOTOR		DIMENSIONS (mm)					WEIGHT kg	
	kW	SIZE	L1	L2	D1	D2	M	PUMP	ELECTRIC PUMP
10SV03..4..	0,55	80	389	263	155	120	129	16,2	22,9
10SV04..4..	0,55	80	421	263	155	120	129	17,1	23,8
10SV06..4..	0,55	80	485	263	155	120	129	18,9	25,6
10SV08..4..	0,55	80	549	263	155	120	129	20,8	27,5
10SV10..4..	0,55	80	613	263	155	120	129	22,7	29,4
10SV13..4..	0,75	80	709	231	159	120	128	25,5	37,6
10SV15..4..	0,75	80	773	231	159	120	128	27,4	39,5
10SV17..4..	1,1	90	847	298	174	140	134	29,8	47,2
10SV19..4..	1,1	90	911	298	174	140	134	31,6	49,1
10SV21..4..	1,1	90	975	298	174	140	134	33,5	50,9

10sv-4p50-en_d_td

**10SV SERIES
OPERATING CHARACTERISTICS AT 50 Hz, 4-POLE**

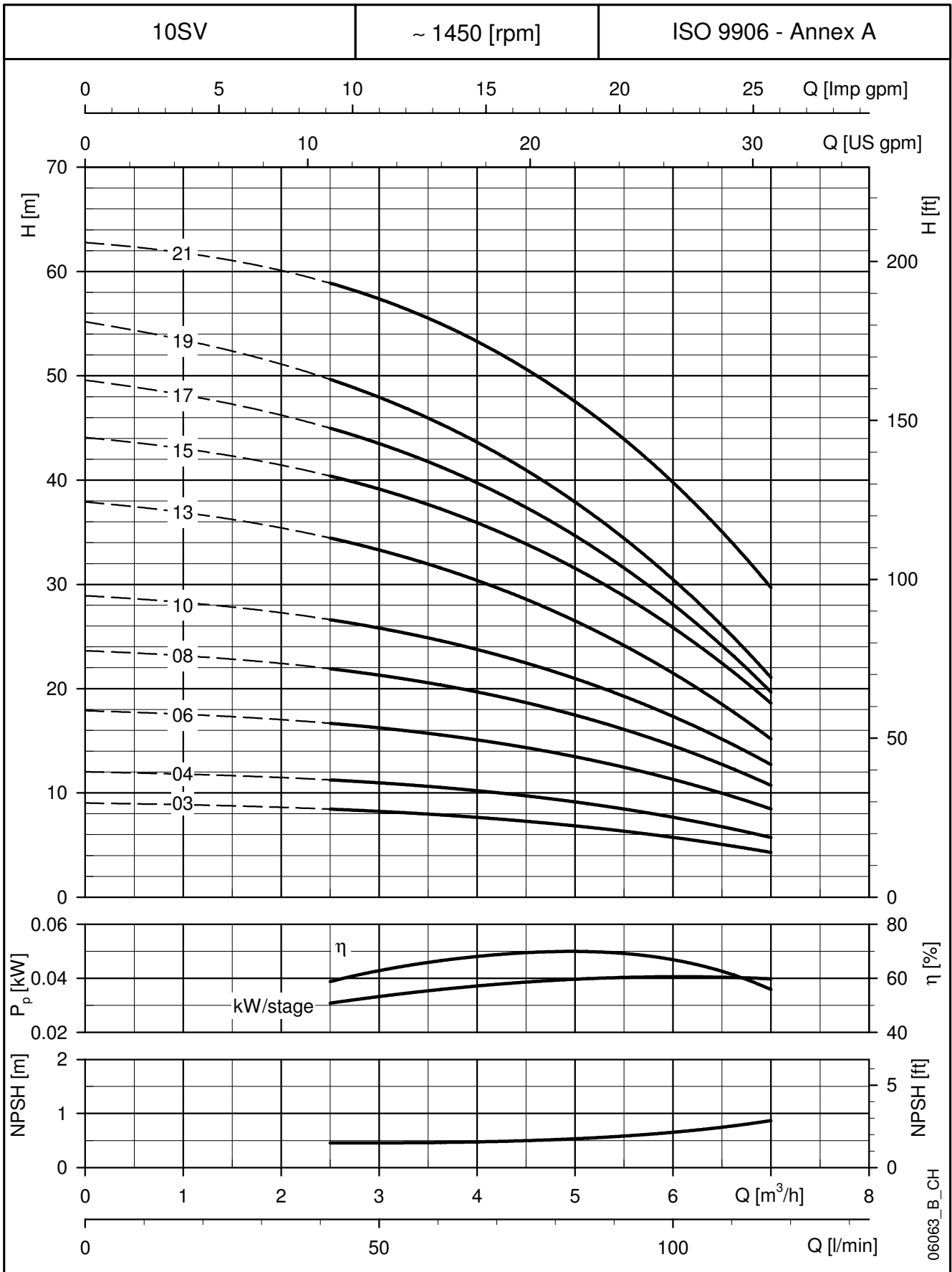

These performances are valid for liquids with density $\rho = 1.0 \text{ Kg/dm}^3$ and kinematic viscosity $\nu = 1 \text{ mm}^2/\text{sec}$.

15SV SERIES DIMENSIONS AND WEIGHTS AT 50 Hz, 4-POLE

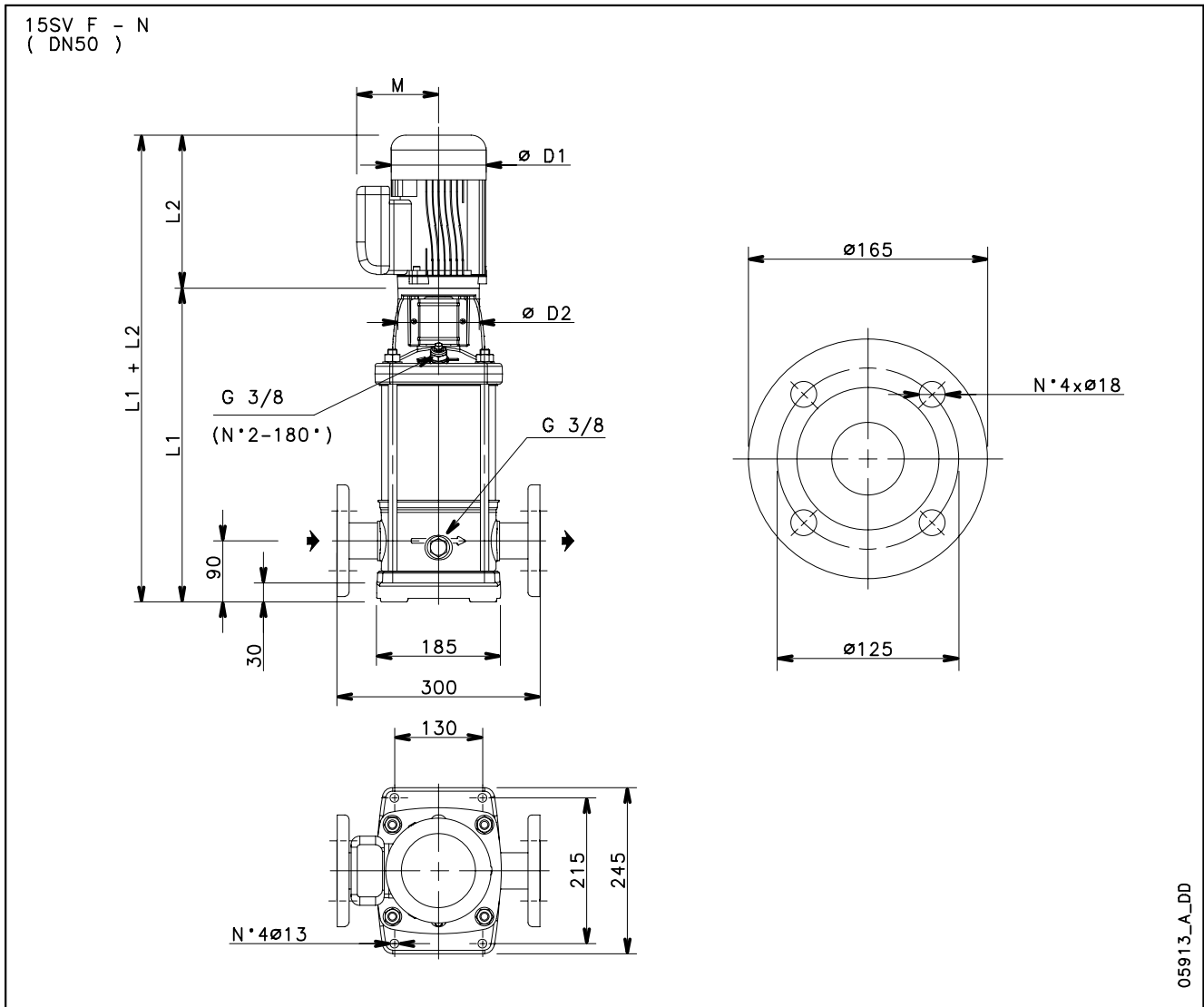

**4-POLE
(50 Hz)**

PUMP TYPE	MOTOR		DIMENSIONS (mm)					WEIGHT kg	
	kW	SIZE	L1	L2	D1	D2	M	PUMP	ELECTRIC PUMP
15SV03..4..	0,55	80	447	263	155	120	129	18,2	24,9
15SV05..4..	0,55	80	543	263	155	120	129	20,6	27,3
15SV07..4..	0,75	80	639	231	159	120	128	23,4	35,5
15SV09..4..	1,1	90	745	298	174	140	134	26,4	43,8
15SV11..4..	1,1	90	841	298	174	140	134	29,1	46,5
15SV13..4..	1,5	90	937	298	174	140	134	31,8	51,8
15SV15..4..	1,5	90	1033	298	174	140	134	34,4	54,4
15SV17..4..	2,2	100	1139	322	214	160	168	38	66,8

**15SV SERIES
OPERATING CHARACTERISTICS AT 50 Hz, 4-POLE**

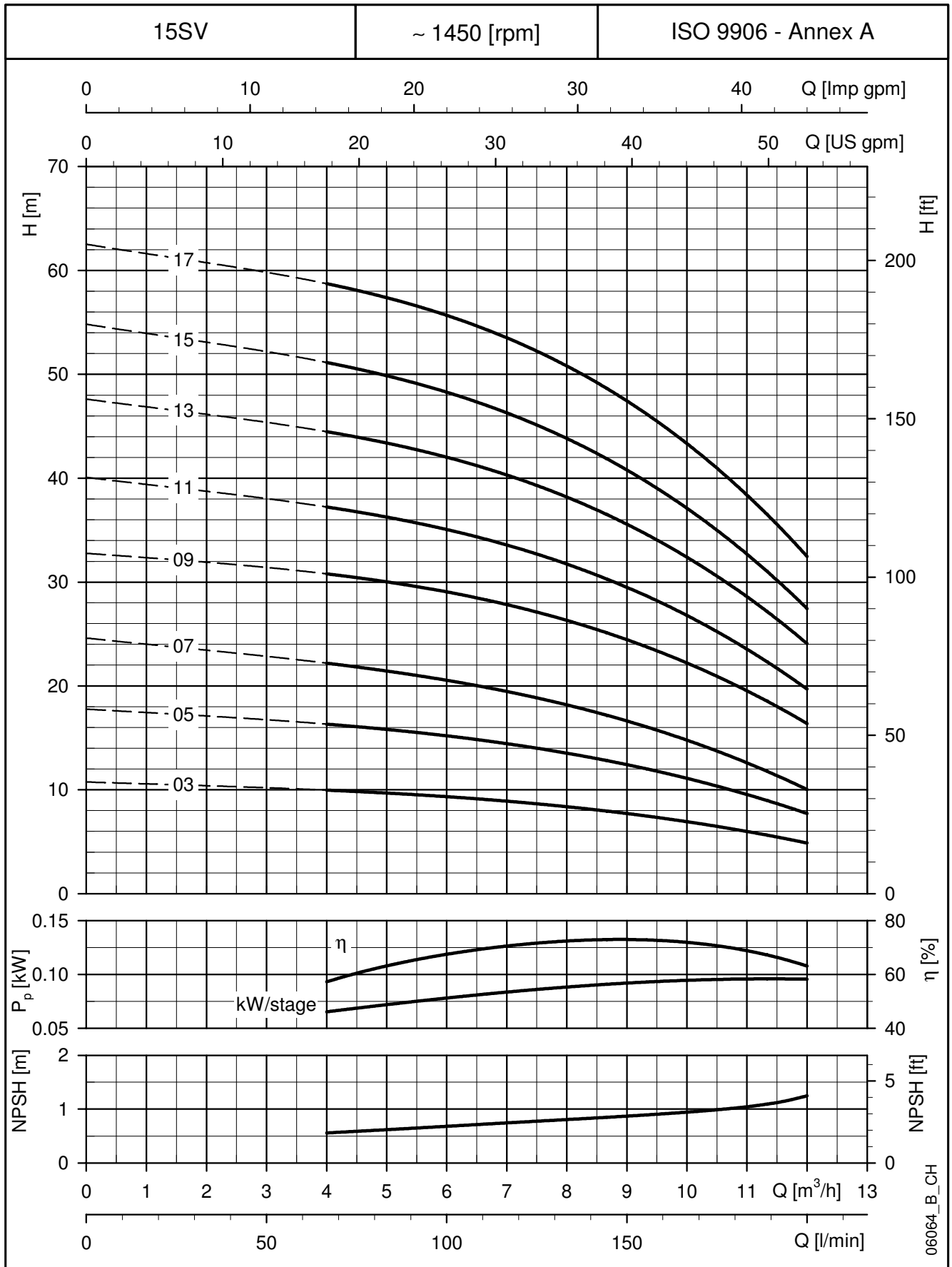

**4-POLE
(50 Hz)**

06064_B_CH

These performances are valid for liquids with density $\rho = 1.0 \text{ Kg/dm}^3$ and kinematic viscosity $\nu = 1 \text{ mm}^2/\text{sec}$.

22SV SERIES
DIMENSIONS AND WEIGHTS AT 50 Hz, 4-POLE

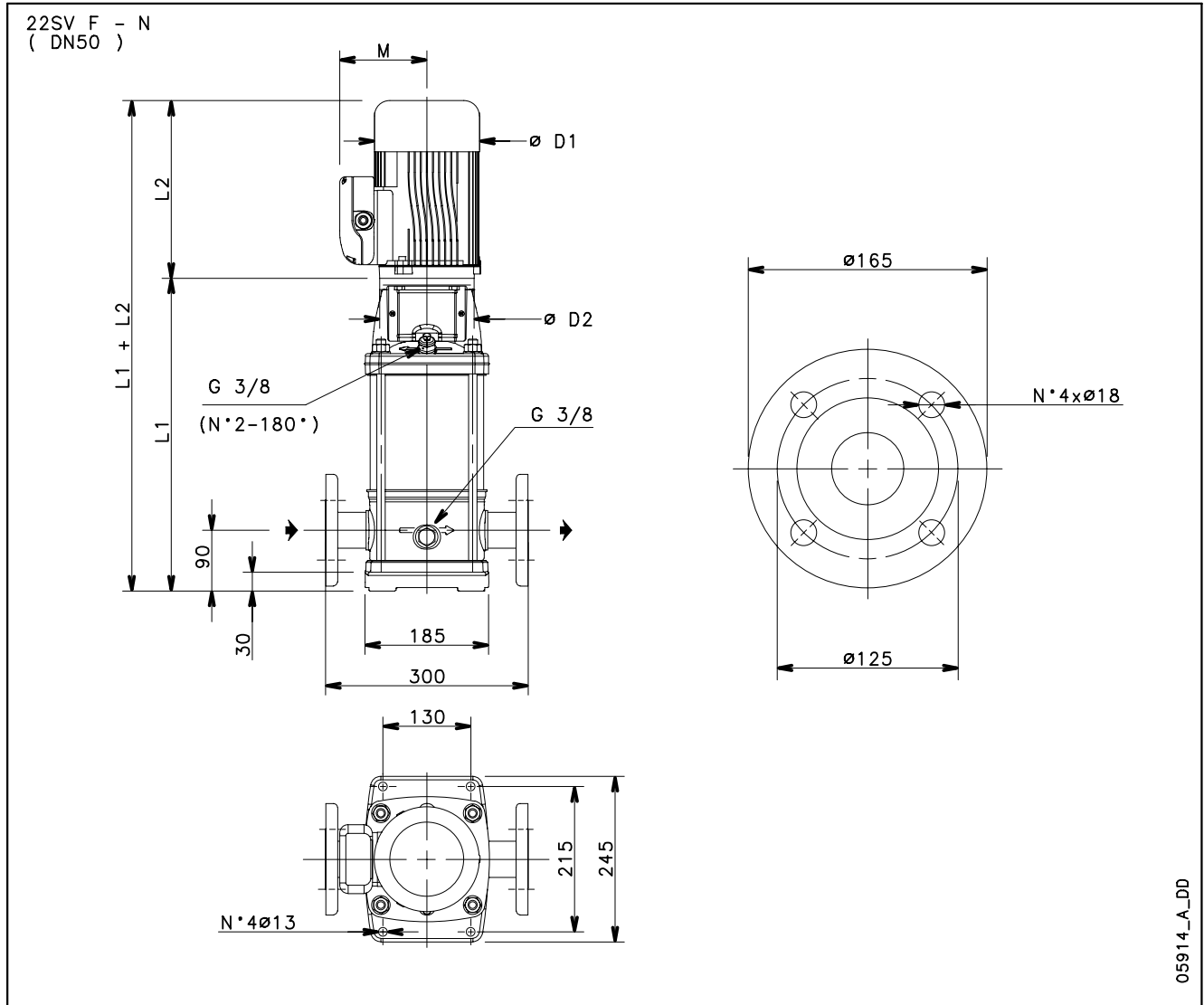

PUMP TYPE	MOTOR		DIMENSIONS (mm)					WEIGHT kg	
	kW	SIZE	L1	L2	D1	D2	M	PUMP	ELECTRIC PUMP
22SV04..4..	0,55	80	495	263	155	120	129	19,3	26
22SV06..4..	1,1	90	601	298	174	140	134	22,4	39,8
22SV08..4..	1,1	90	697	298	174	140	134	25,1	42,5
22SV10..4..	1,5	90	793	298	174	140	134	27,8	47,8
22SV12..4..	2,2	100	899	322	214	160	168	31,3	60,1
22SV14..4..	2,2	100	995	322	214	160	168	34	62,8
22SV17..4..	3	100	1139	353	214	160	168	38	70

**22SV SERIES
OPERATING CHARACTERISTICS AT 50 Hz, 4-POLE**

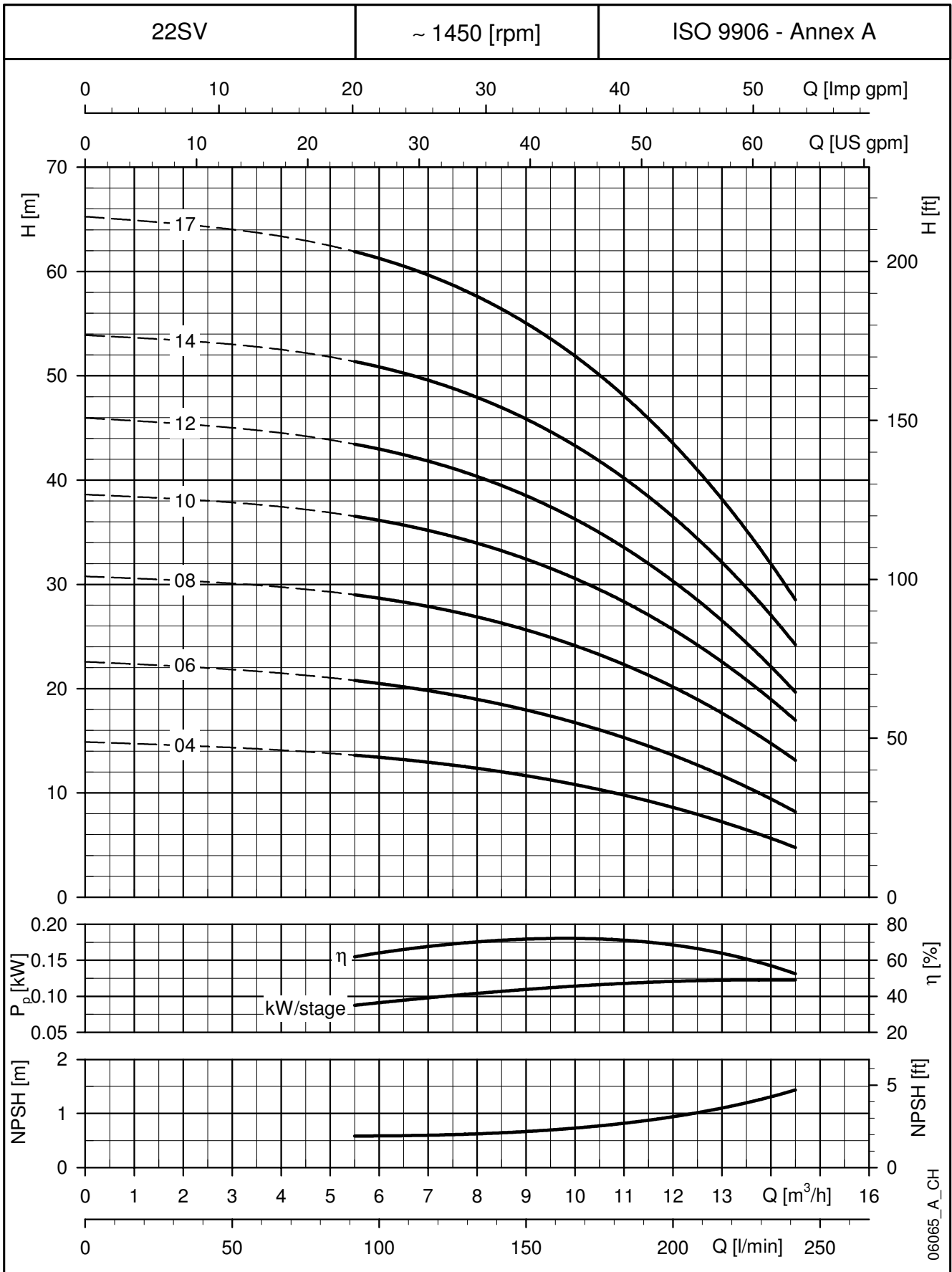

**4-POLE
(50 Hz)**

These performances are valid for liquids with density $\rho = 1.0 \text{ Kg/dm}^3$ and kinematic viscosity $\nu = 1 \text{ mm}^2/\text{sec}$.

33SV SERIES
DIMENSIONS AND WEIGHTS AT 50 Hz, 4-POLE

33SV G - N
(DN65)

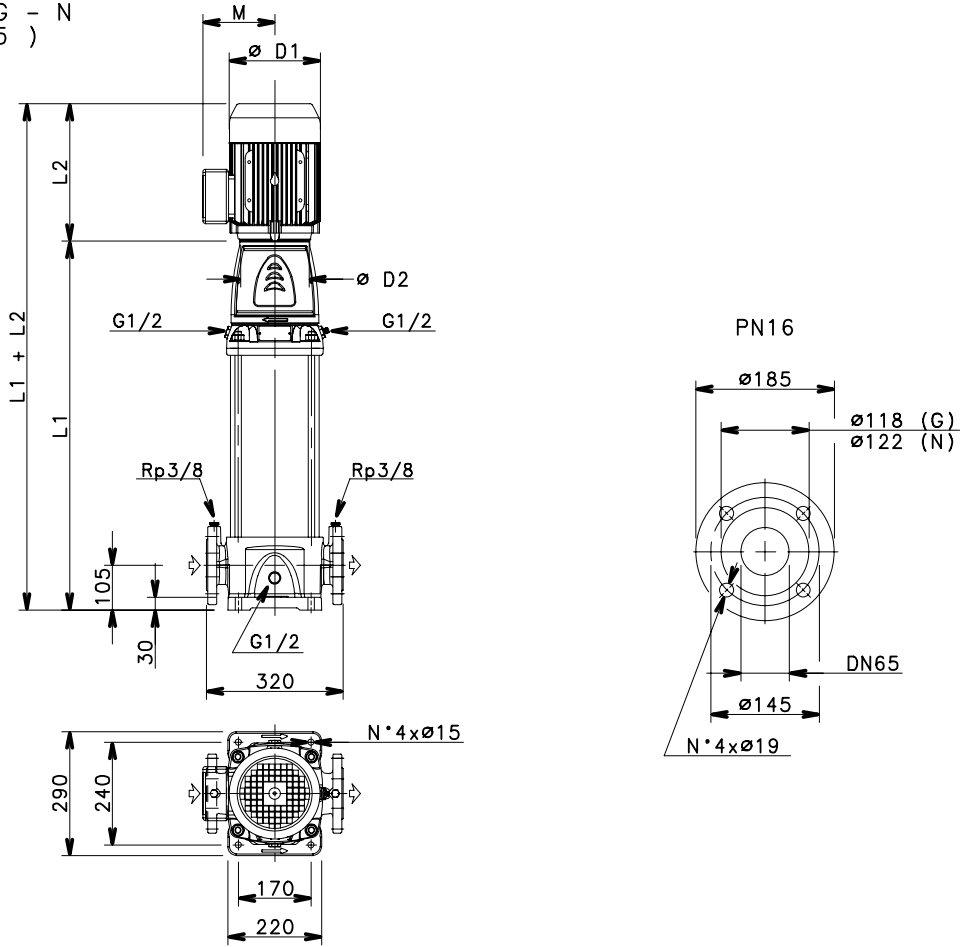

05125_D_DD

4-POLE
(50 Hz)

PUMP TYPE	MOTOR		DIMENSIONS (mm)						WEIGHT kg	
	kW	SIZE	L1	L2	D1	D2	M	PN	PUMP	ELECTRIC PUMP
33SV3/2A..4..	1,1	90	639	298	174	164	134	16	60	78
33SV4/1A..4..	1,1	90	714	298	174	164	134	16	64	82
33SV5..4..	1,5	90	789	298	174	164	134	16	68	91
33SV6..4..	2,2	100	864	322	214	164	168	16	72	101
33SV7..4..	2,2	100	939	322	214	164	168	16	75	104
33SV8..4..	3	100	1014	353	214	164	168	16	79	111
33SV9..4..	3	100	1089	353	214	164	168	16	83	115
33SV10..4..	3	100	1164	353	214	164	168	16	87	119
33SV11..4..	4	112	1239	398	214	164	168	16	96	150
33SV12..4..	4	112	1314	398	214	164	168	16	100	154
33SV13..4..	4	112	1389	398	214	164	168	16	103	157

33SV SERIES OPERATING CHARACTERISTICS AT 50 Hz, 4-POLE

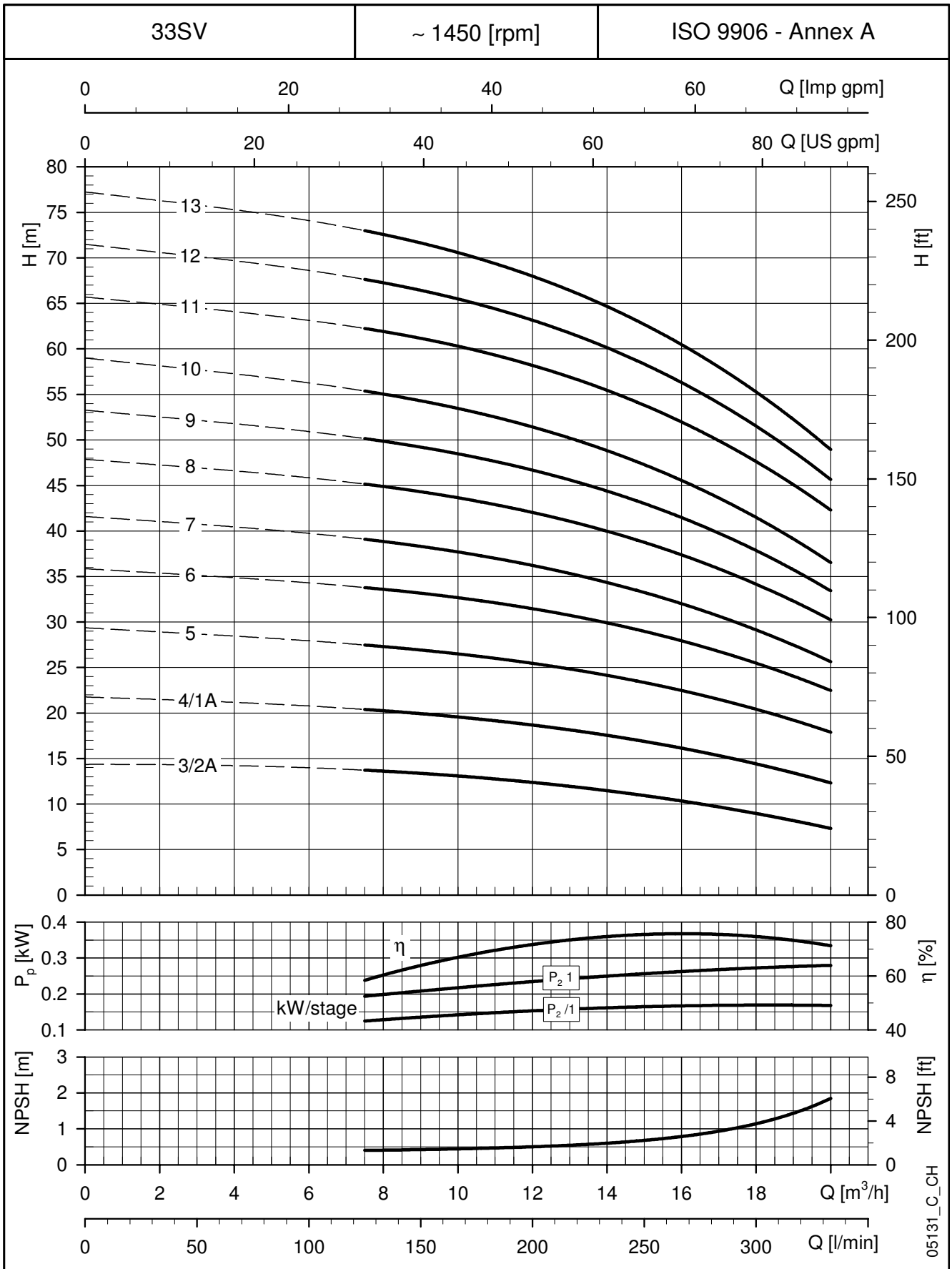

**4-POLE
(50 Hz)**

These performances are valid for liquids with density $\rho = 1.0 \text{ Kg/dm}^3$ and kinematic viscosity $\nu = 1 \text{ mm}^2/\text{sec}$.

46SV SERIES
DIMENSIONS AND WEIGHTS AT 50 Hz, 4-POLE

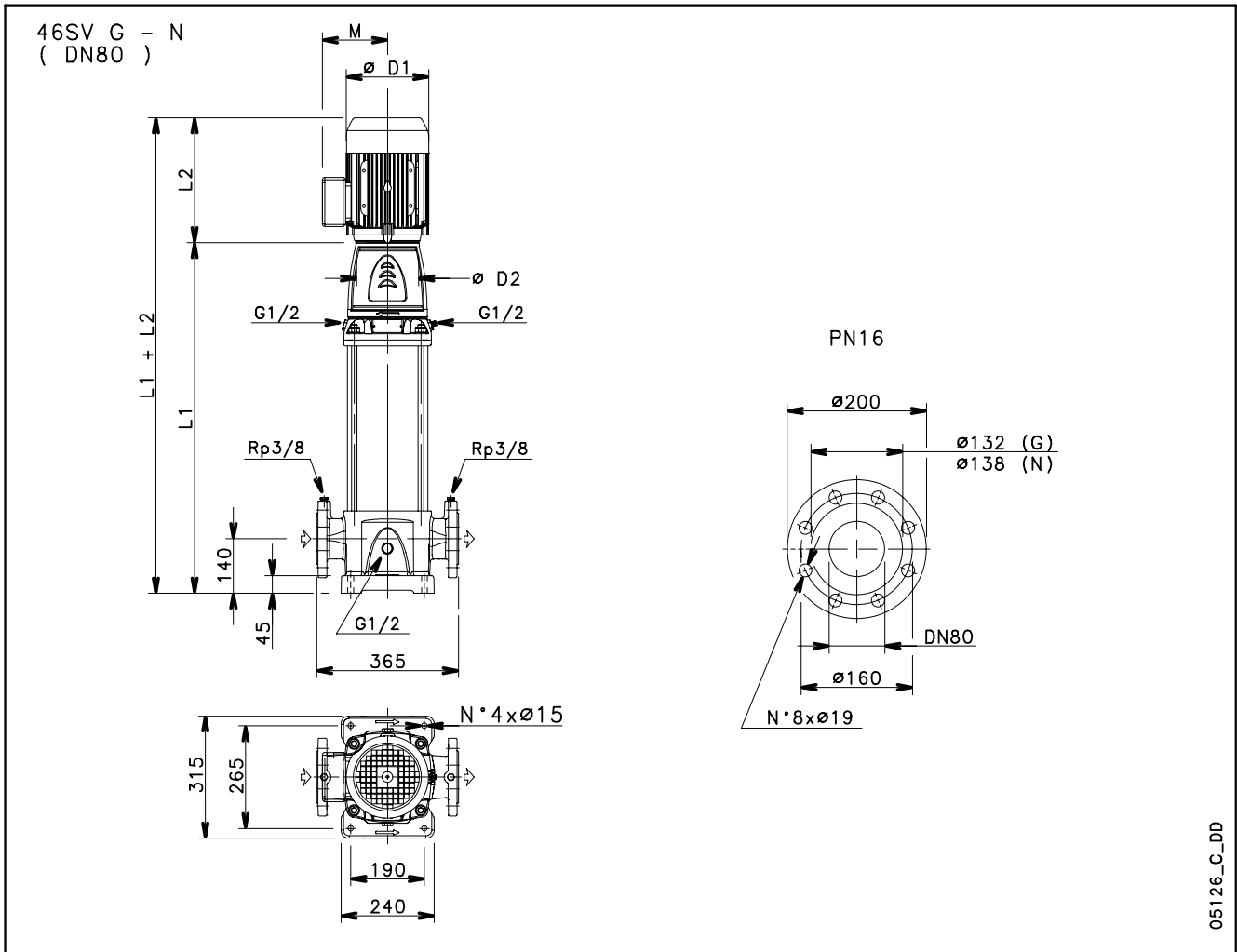

05126_C_DD

PUMP TYPE	MOTOR		DIMENSIONS (mm)						WEIGHT kg	
	kW	SIZE	L1	L2	D1	D2	M	PN	PUMP	ELECTRIC PUMP
46SV2..4..	1,1	90	604	298	174	164	134	16	61	79
46SV3..4..	1,5	90	679	298	174	164	134	16	65	88
46SV4..4..	2,2	100	754	322	214	164	168	16	69	98
46SV5..4..	2,2	100	829	322	214	164	168	16	73	102
46SV6..4..	3	100	904	353	214	164	168	16	77	109
46SV7..4..	3	100	979	353	214	164	168	16	80	112
46SV8..4..	4	112	1054	398	214	164	168	16	84	138
46SV9..4..	4	112	1129	398	214	164	168	16	88	142
46SV10..4..	5,5	132	1224	405	256	300	191	16	97	156
46SV11..4..	5,5	132	1299	405	256	300	191	16	105	164
46SV12..4..	5,5	132	1374	405	256	300	191	16	109	168

46sv-4p50-en_b_td

4-POLE
(50 Hz)

**46SV SERIES
OPERATING CHARACTERISTICS AT 50 Hz, 4-POLE**

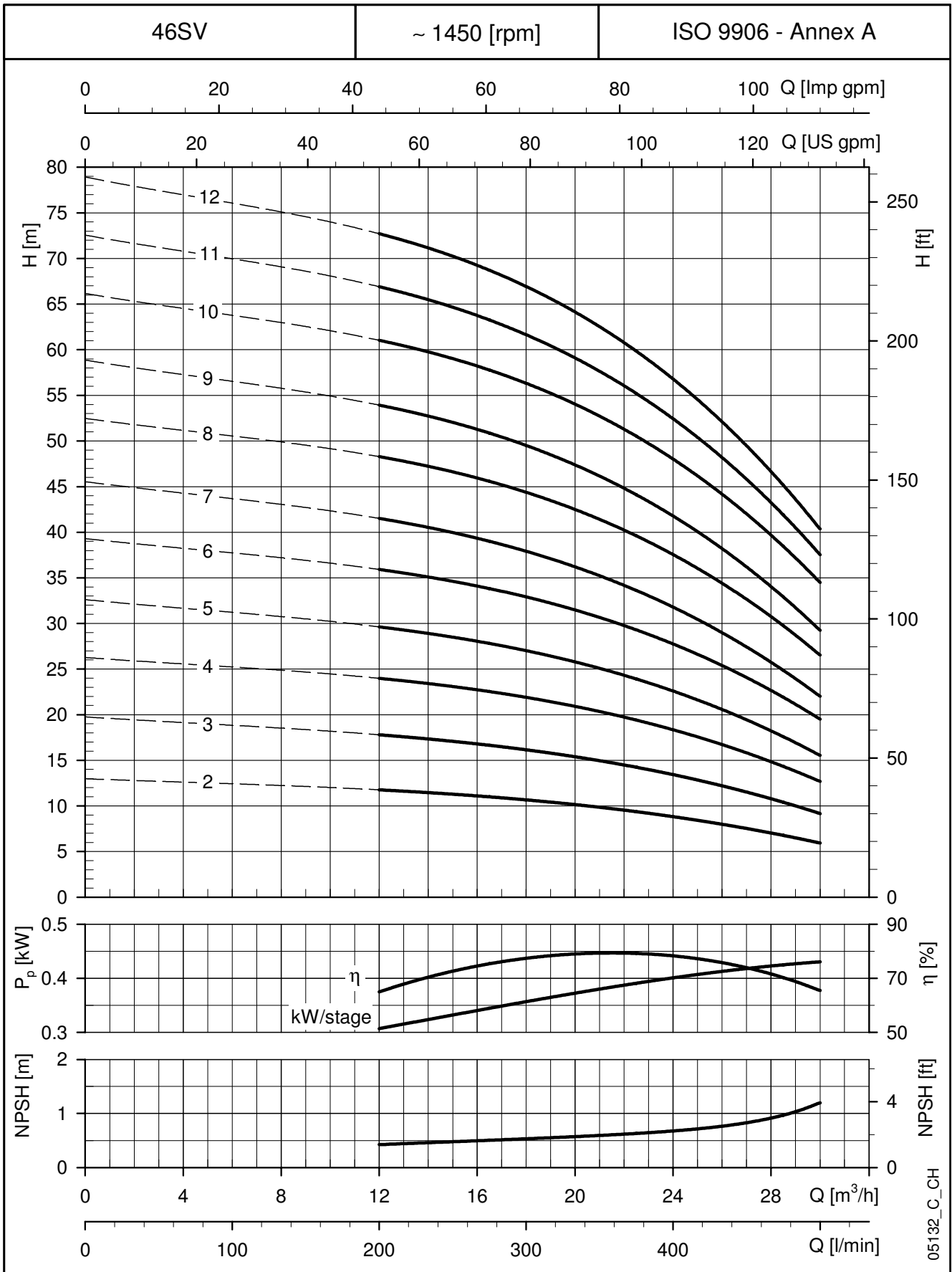

**4-POLE
(50 Hz)**

These performances are valid for liquids with density $\rho = 1.0 \text{ Kg/dm}^3$ and kinematic viscosity $\nu = 1 \text{ mm}^2/\text{sec}$.

66SV SERIES
DIMENSIONS AND WEIGHTS AT 50 Hz, 4-POLE

4-POLE
(50 Hz)

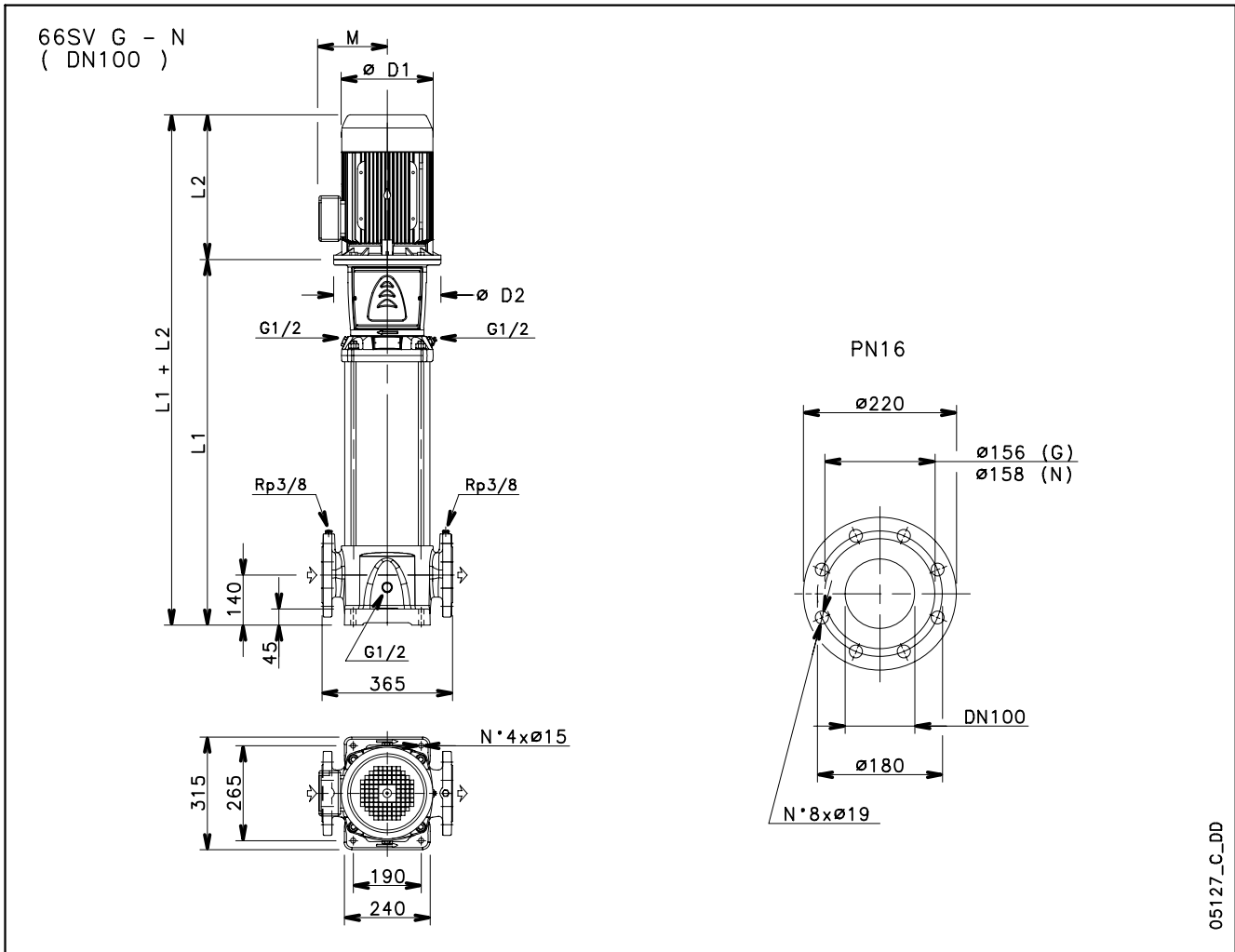

05127_C_DD

PUMP TYPE	MOTOR		DIMENSIONS (mm)						WEIGHT kg	
	kW	SIZE	L1	L2	D1	D2	M	PN	PUMP	ELECTRIC PUMP
66SV1..4..	1,1	90	554	298	174	164	134	16	66	84
66SV2..4..	1,5	90	644	298	174	164	134	16	72	95
66SV3..4..	2,2	100	734	322	214	164	168	16	77	106
66SV4..4..	3	100	824	353	214	164	168	16	82	114
66SV5..4..	4	112	914	398	214	164	168	16	87	141
66SV6..4..	4	112	1004	398	214	164	168	16	93	147
66SV7..4..	5,5	132	1114	405	256	300	191	16	103	166
66SV8..4..	5,5	132	1204	405	256	300	191	16	108	171

**66SV SERIES
OPERATING CHARACTERISTICS AT 50 Hz, 4-POLE**

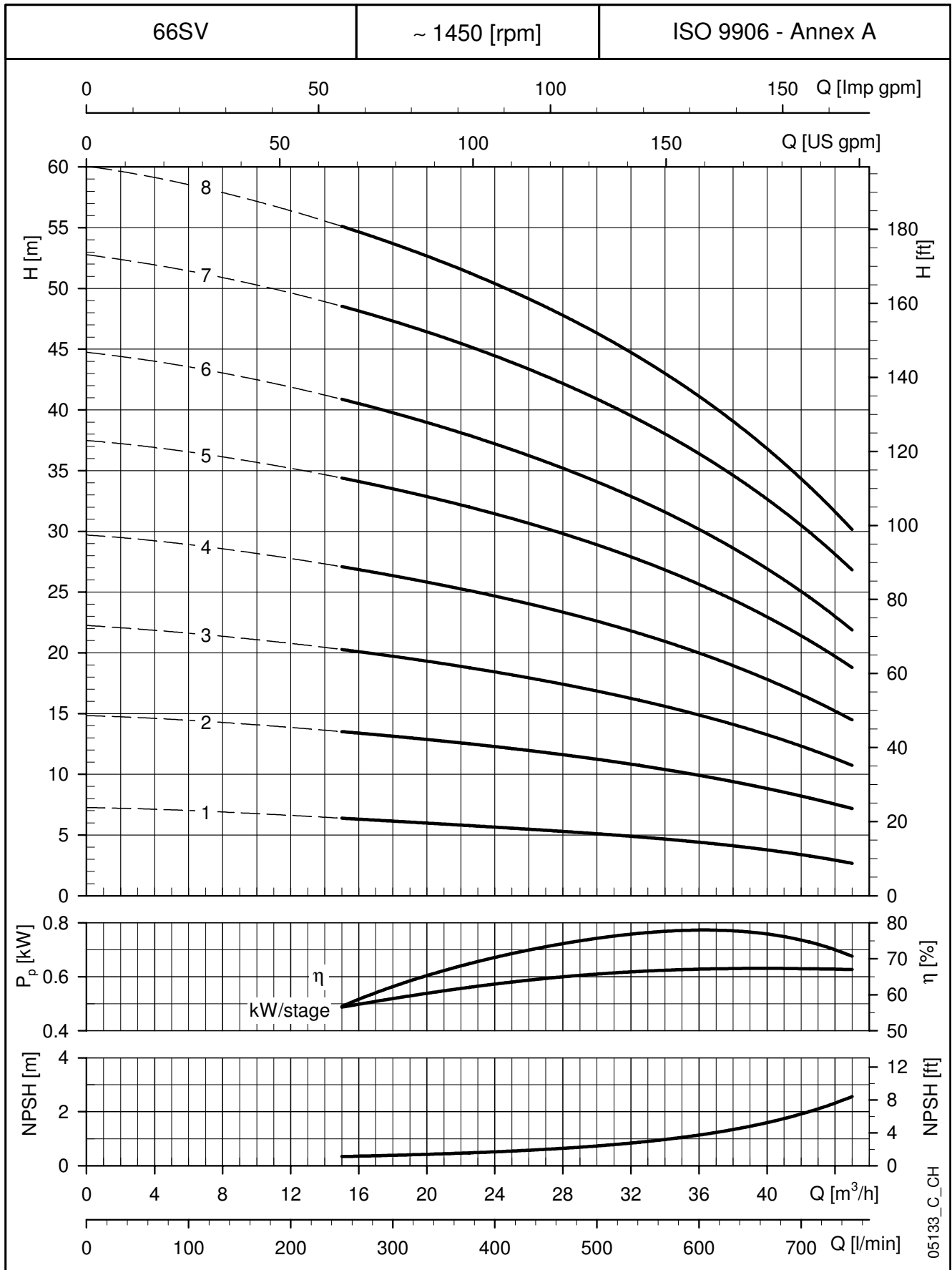

These performances are valid for liquids with density $\rho = 1.0 \text{ Kg/dm}^3$ and kinematic viscosity $\nu = 1 \text{ mm}^2/\text{sec}$.

92SV SERIES DIMENSIONS AND WEIGHTS AT 50 Hz, 4-POLE

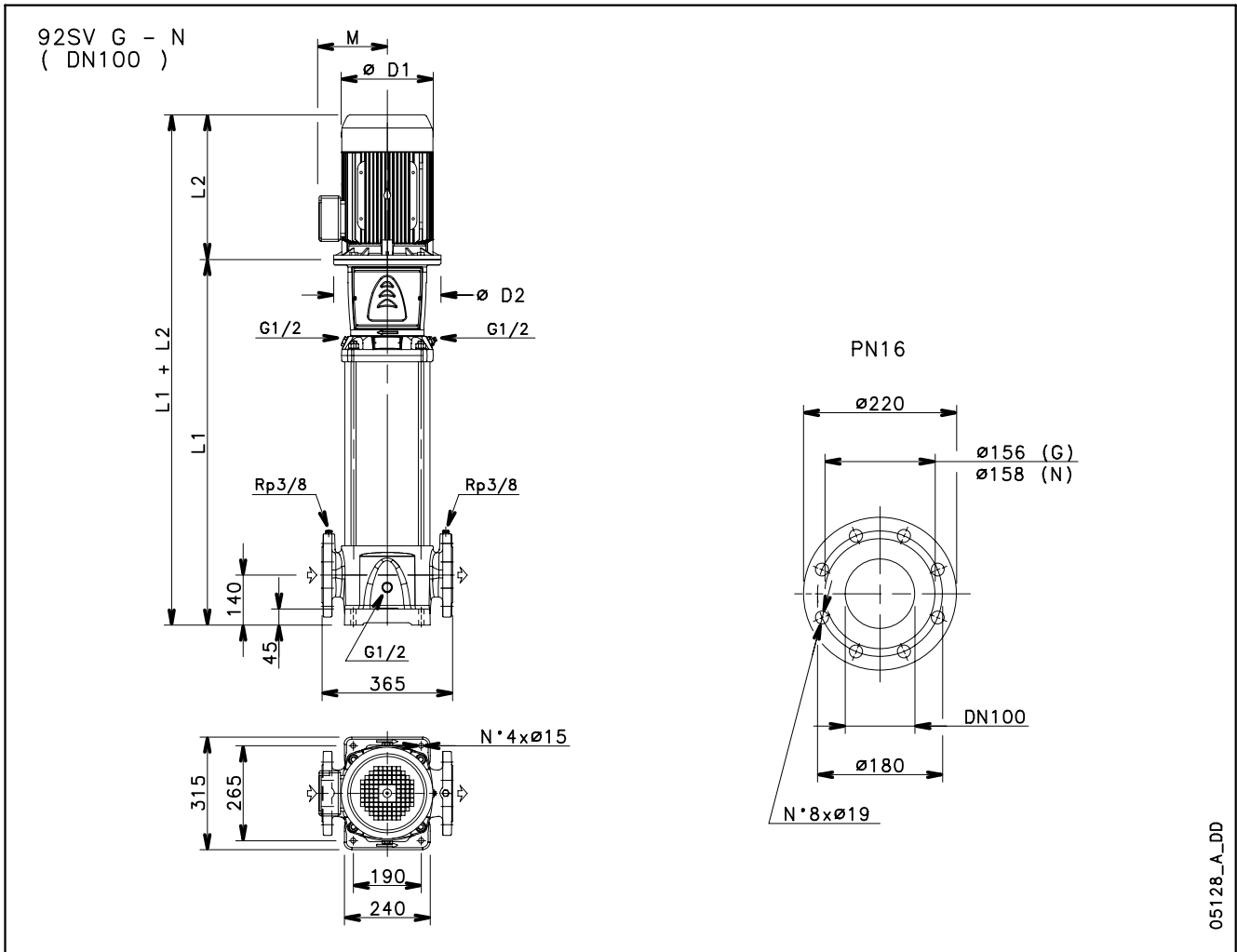

**4-POLE
(50 Hz)**

PUMP TYPE	MOTOR		DIMENSIONS (mm)						WEIGHT kg	
	kW	SIZE	L1	L2	D1	D2	M	PN	PUMP	ELECTRIC PUMP
92SV1..4..	1,1	90	554	298	174	164	134	16	66	84
92SV2..4..	2,2	100	644	322	214	164	168	16	71	100
92SV3..4..	3	100	734	353	214	164	168	16	77	109
92SV4..4..	4	112	824	398	214	164	168	16	82	136
92SV5..4..	5,5	132	934	405	256	300	191	16	91	154
92SV6..4..	5,5	132	1024	405	256	300	191	16	97	160
92SV7..4..	7,5	132	1114	405	256	300	191	16	102	169
92SV8..4..	7,5	132	1204	405	256	300	191	16	107	174

**92SV SERIES
OPERATING CHARACTERISTICS AT 50 Hz, 4-POLE**

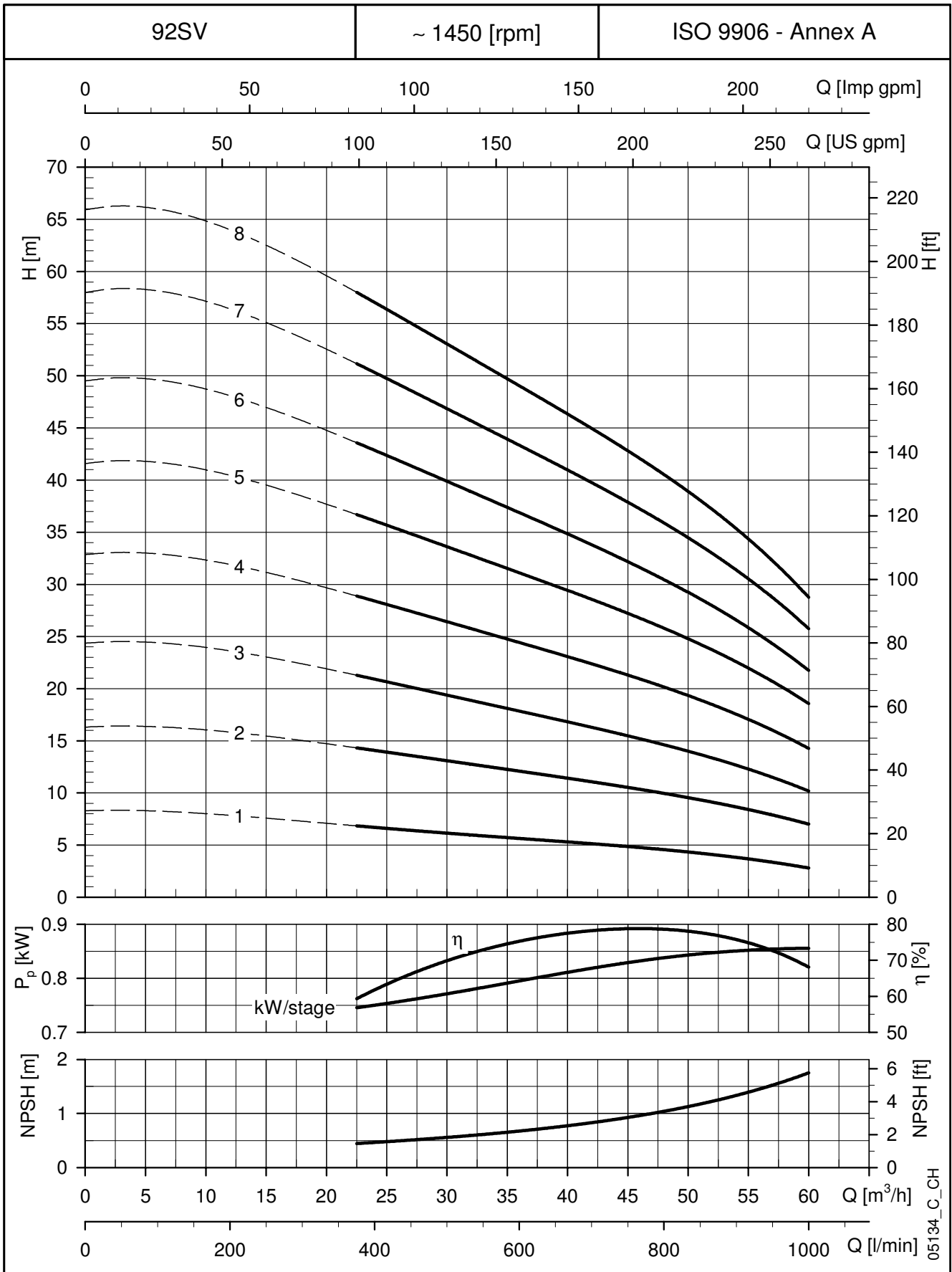

These performances are valid for liquids with density $\rho = 1.0 \text{ Kg/dm}^3$ and kinematic viscosity $\nu = 1 \text{ mm}^2/\text{sec}$.

125SV SERIES
DIMENSIONS AND WEIGHTS AT 50 Hz, 4-POLE

125SV G - N
(DN125)

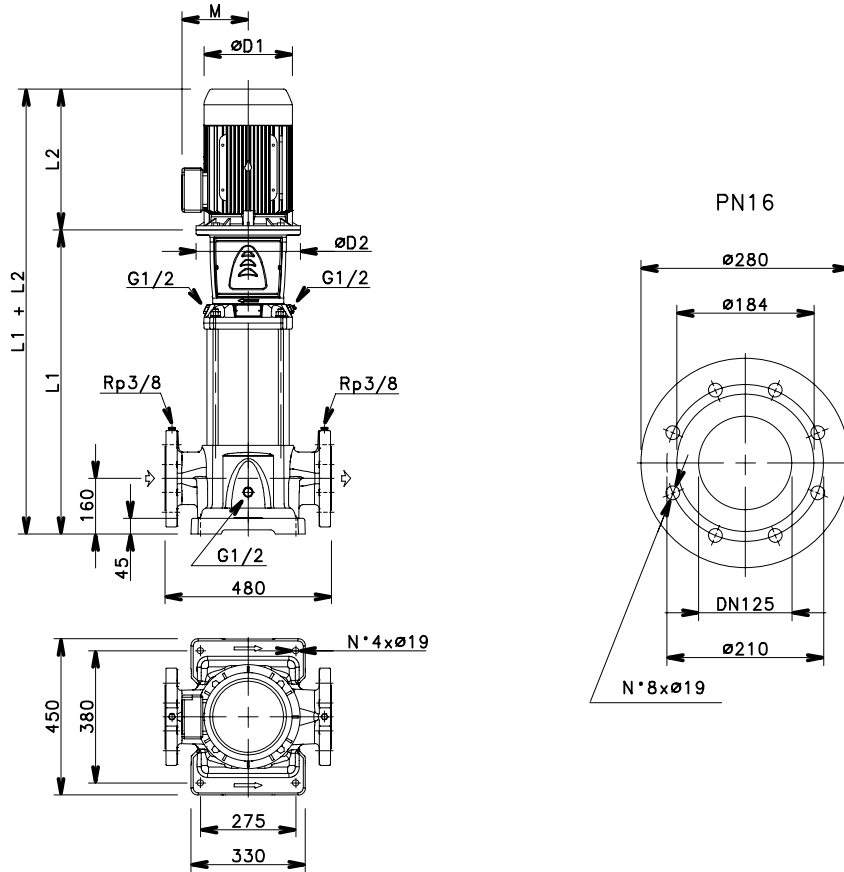

05915_A_DD

4-POLE
(50 Hz)

PUMP TYPE	MOTOR		DIMENSIONS (mm)						WEIGHT kg	
	kW	SIZE	L1	L2	D1	D2	M	PN	PUMP	ELECTRIC PUMP
125SV1..4..	1,1	90	673	298	174	140	134	16	110	128
125SV2..4..	2,2	100	823	322	214	160	168	16	121	150
125SV3/3B..4..	2,2	100	973	322	214	160	168	16	133	162
125SV4/4B..4..	3	100	1123	353	214	160	168	16	144	176
125SV5/5A..4..	4	112	1273	398	214	160	168	16	155	207
125SV6..4..	5,5	132	1443	405	256	300	191	16	172	234
125SV7..4..	7,5	132	1593	405	256	300	191	16	186	253
125SV8..4..	7,5	132	1743	405	256	300	191	16	199	265

125sv-4p50-en_b_td

**125SV SERIES
OPERATING CHARACTERISTICS AT 50 Hz, 4-POLE**

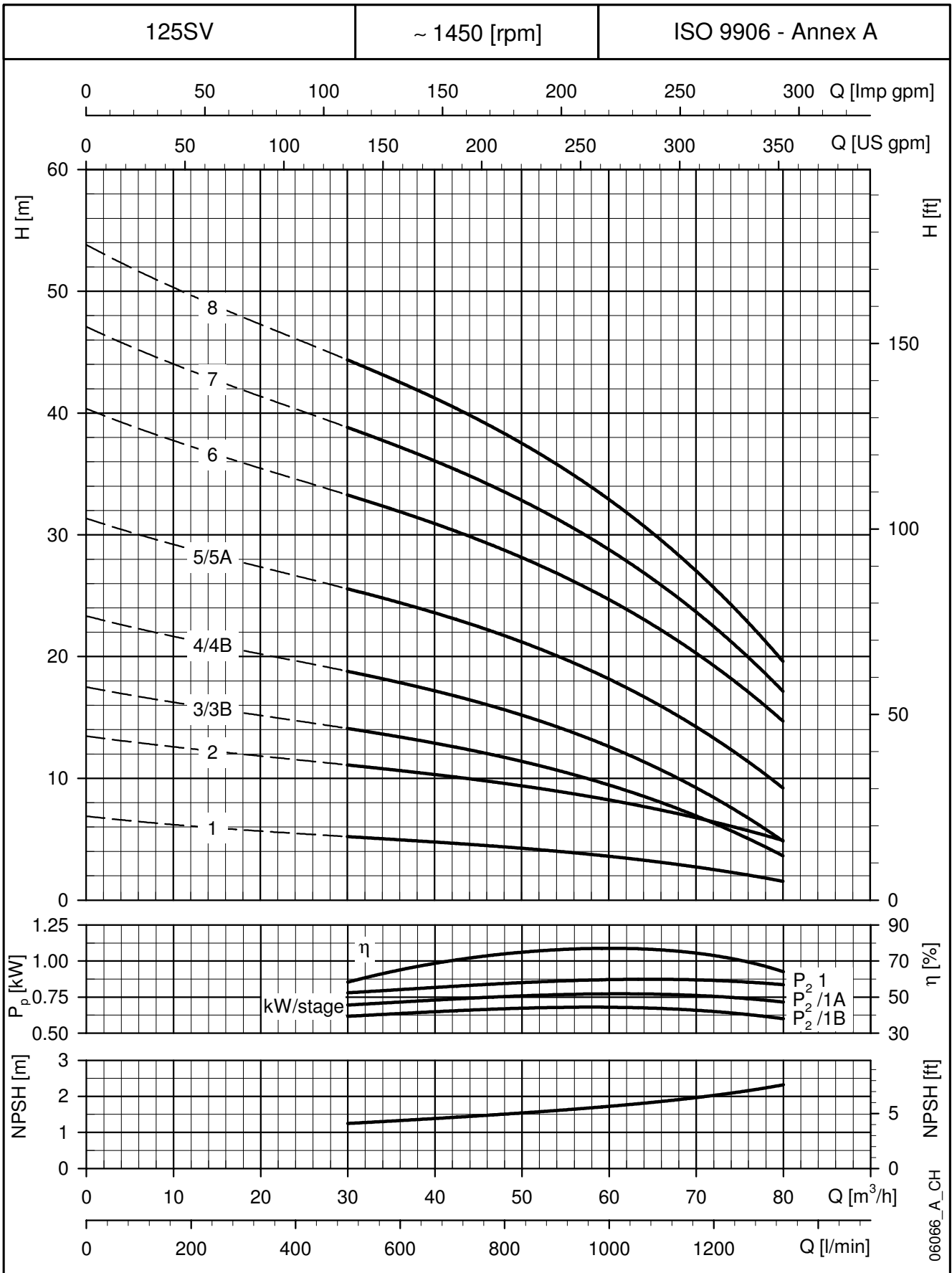

**4-POLE
(50 Hz)**

These performances are valid for liquids with density $\rho = 1.0 \text{ Kg/dm}^3$ and kinematic viscosity $\nu = 1 \text{ mm}^2/\text{sec}$.

e-SV™ SERIES
HYDRAULIC PERFORMANCE RANGE AT 60 Hz, 4-POLE

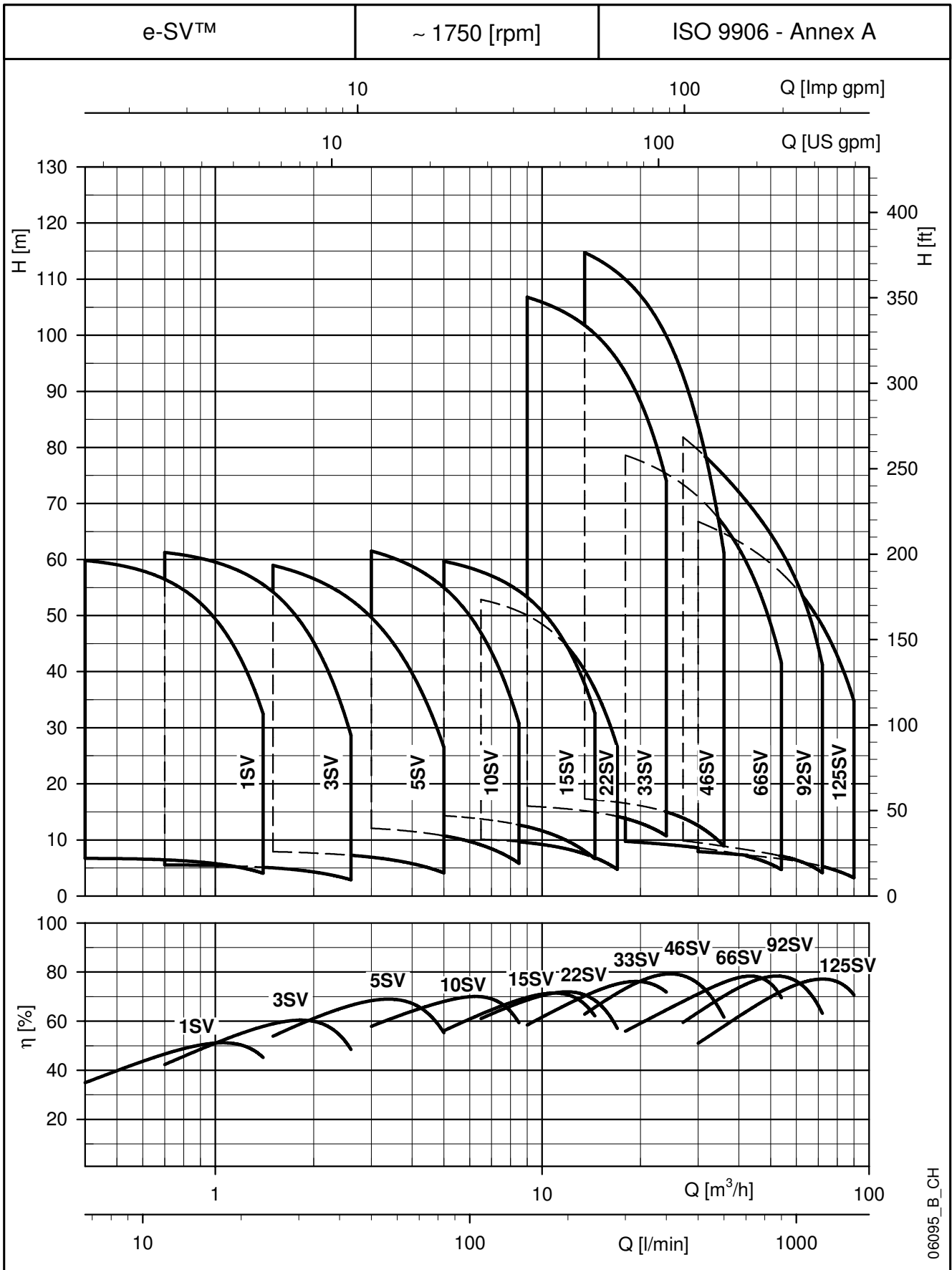

06095_B_CH

1, 3, 5SV SERIES HYDRAULIC PERFORMANCE TABLE AT 60 Hz, 4-POLE

PUMP TYPE	RATED POWER		Q = DELIVERY													
	kW	HP	l/min	6,7	10	11,7	15	18	23,33	25	30	35	43,3	50	60	83,33
			m ³ /h	0,4	0,6	0,7	0,9	1,1	1,4	1,5	1,8	2,1	2,6	3,0	3,6	5,0
H = TOTAL HEAD IN METRES OF COLUMN OF WATER																
1SV03..4	0,25	0,34	6,6	6,7	6,6	6,4	6,1	5,5	4,1							
1SV05..4	0,25	0,34	11,0	11,1	10,9	10,7	10,0	9,1	6,6							
1SV07..4	0,25	0,34	15,3	15,5	15,2	14,8	13,9	12,6	9,2							
1SV09..4	0,25	0,34	19,6	19,8	19,4	18,9	17,7	16,0	11,6							
1SV11..4	0,25	0,34	23,9	24,1	23,5	23,0	21,4	19,3	13,9							
1SV13..4	0,25	0,34	28,2	28,3	27,6	26,9	25,1	22,6	16,1							
1SV15..4	0,25	0,34	32,4	32,5	31,6	30,9	28,6	25,8	18,3							
1SV17..4	0,25	0,34	36,6	36,7	35,6	34,7	32,2	28,9	20,4							
1SV18..4	0,25	0,34	38,7	38,7	37,6	36,6	33,9	30,4	21,4							
1SV20..4	0,25	0,34	42,9	42,8	41,5	40,4	37,4	33,5	23,3							
1SV22..4	0,25	0,34	47,0	46,8	45,3	44,1	40,7	36,4	25,3							
1SV24..4	0,25	0,34	51,1	50,8	49,1	47,7	44,0	39,2	27,0							
1SV26..4	0,37	0,5	55,2	54,7	52,8	51,3	47,3	42,1	28,7							
1SV28..4	0,37	0,5	60,0	59,8	58,0	56,5	52,2	46,7	32,5							
3SV02..4	0,25	0,34	5,5			5,5	5,5	5,4	5,1	5,0	4,6	4,1	2,9			
3SV04..4	0,25	0,34	10,9			11,0	10,8	10,6	10,1	9,9	9,1	8,0	5,6			
3SV06..4	0,25	0,34	16,3			16,3	16,1	15,8	14,9	14,6	13,3	11,7	8,1			
3SV08..4	0,25	0,34	21,6			21,4	21,1	20,6	19,5	19,0	17,3	15,2	10,3			
3SV10..4	0,25	0,34	26,8			26,5	26,0	25,4	24,0	23,4	21,3	18,5	12,4			
3SV12..4	0,25	0,34	32,0			31,5	30,9	30,1	28,3	27,6	25,0	21,7	14,4			
3SV14..4	0,37	0,5	37,6			37,1	36,4	35,6	33,5	32,7	29,7	25,8	17,3			
3SV15..4	0,37	0,5	40,4			39,9	39,2	38,3	36,1	35,2	32,0	27,9	18,6			
3SV17..4	0,37	0,5	45,5			44,9	44,1	43,0	40,5	39,4	35,7	31,0	20,4			
3SV19..4	0,37	0,5	50,7			49,8	48,8	47,6	44,7	43,5	39,3	33,9	22,1			
3SV21..4	0,55	0,75	55,8			54,6	53,5	52,1	48,8	47,5	42,8	36,8	23,7			
3SV23..4	0,55	0,75	61,9			61,3	60,2	58,9	55,6	54,2	49,3	42,9	28,7			
5SV03..4	0,25	0,34	8,3							7,9	7,8	7,6	7,3	6,9	6,3	4,1
5SV05..4	0,25	0,34	13,7							13,0	12,7	12,4	11,8	11,2	10,1	6,5
5SV07..4	0,25	0,34	18,8							18,0	17,7	17,2	16,3	15,4	13,8	8,5
5SV09..4	0,37	0,5	24,0							22,8	22,3	21,7	20,5	19,3	17,1	10,3
5SV11..4	0,37	0,5	29,5							28,1	27,5	26,7	25,3	23,8	21,2	12,9
5SV13..4	0,55	0,75	34,7							32,7	31,9	30,9	29,0	27,2	24,0	14,1
5SV15..4	0,55	0,75	40,4							38,6	37,7	36,7	34,6	32,6	29,0	17,6
5SV17..4	0,55	0,75	45,6							43,4	42,4	41,2	38,8	36,5	32,4	19,4
5SV19..4	0,75	1	50,8							48,1	47,0	45,6	42,9	40,3	35,6	21,1
5SV21..4	0,75	1	56,7							54,1	52,9	51,5	48,6	45,8	40,7	24,8
5SV23..4	0,75	1	61,9							59,0	57,6	56,0	52,8	49,7	44,1	26,6

Performances in compliance with ISO 9906 - Annex A.

1-5sv-4p60-en_a_th

**4-POLE
(60 Hz)**

10, 15, 22SV SERIES

HYDRAULIC PERFORMANCE TABLE AT 60 Hz, 4-POLE

PUMP TYPE	RATED POWER		Q = DELIVERY													
	kW	HP	l/min 0	50	60	70	83,33	95	108,3	141,6	160	175	241,6	250	265	283,3
			m ³ /h 0	3,0	3,6	4,2	5,0	5,7	6,5	8,5	9,6	10,5	14,5	15,0	15,9	17,0
H = TOTAL HEAD IN METRES OF COLUMN OF WATER																
10SV03..4	0,55	0,75	13,0	12,1	11,8	11,4	10,7	10,1	9,1	5,9						
10SV05..4	0,55	0,75	21,6	20,0	19,4	18,8	17,7	16,6	15,0	9,4						
10SV07..4	0,75	1	29,9	27,2	26,4	25,5	23,9	22,2	19,9	12,1						
10SV09..4	0,75	1	38,5	35,4	34,4	33,2	31,2	29,1	26,3	16,4						
10SV11..4	1,1	1,5	47,8	44,9	43,8	42,5	40,3	37,9	34,5	22,8						
10SV13..4	1,1	1,5	56,2	52,8	51,5	49,8	47,1	44,1	40,0	26,0						
10SV15..4	1,5	2	65,1	61,5	60,0	58,1	55,0	51,6	46,9	30,8						
15SV03..4	0,55	0,75	15,4				14,3	14,1	13,7	12,7	11,9	11,2	6,7			
15SV04..4	0,75	1	20,6				19,2	18,9	18,4	17,0	16,0	15,1	9,0			
15SV05..4	1,1	1,5	26,2				24,7	24,4	23,9	22,3	21,1	20,0	12,7			
15SV06..4	1,1	1,5	31,3				29,5	29,1	28,5	26,5	25,1	23,7	14,9			
15SV07..4	1,5	2	36,7				34,7	34,2	33,5	31,3	29,7	28,1	17,8			
15SV08..4	1,5	2	42,4				39,6	39,1	38,4	36,0	34,3	32,6	21,5			
15SV09..4	2,2	3	48,0				45,2	44,6	43,8	41,3	39,4	37,5	25,1			
15SV10..4	2,2	3	53,3				50,0	49,4	48,5	45,7	43,6	41,5	27,7			
15SV11..4	2,2	3	58,5				54,9	54,2	53,2	50,1	47,7	45,4	30,2			
15SV12..4	2,2	3	63,8				59,7	58,9	57,9	54,4	51,8	49,3	32,6			
22SV02..4	0,55	0,75	11,0						10,1	9,7	9,3	9,0	6,9	6,5	5,8	4,8
22SV03..4	0,75	1	16,5						15,1	14,4	13,9	13,4	10,2	9,6	8,5	7,0
22SV04..4	1,1	1,5	22,2						21,1	20,3	19,7	19,0	14,8	14,0	12,6	10,6
22SV05..4	1,5	2	27,7						26,2	25,1	24,3	23,5	18,1	17,2	15,4	12,9
22SV06..4	1,5	2	33,3						31,7	30,4	29,5	28,5	22,1	21,0	18,9	15,9
22SV07..4	2,2	3	39,1						37,4	36,0	34,9	33,8	26,5	25,2	22,7	19,3
22SV08..4	2,2	3	44,6						42,6	40,9	39,7	38,4	30,0	28,6	25,7	21,8
22SV09..4	2,2	3	50,1						47,7	45,9	44,4	43,0	33,5	31,9	28,6	24,2
22SV10..4	3	4	55,6						52,8	50,7	49,1	47,6	36,9	35,1	31,5	26,6

Performances in compliance with ISO 9906 - Annex A.

10-22sv-4p60-en_a_th

**4-POLE
(60 Hz)**

33, 46, 66, 92, 125SV SERIES

HYDRAULIC PERFORMANCE TABLE AT 60 Hz, 4-POLE

PUMP TYPE	RATED POWER		Q = CAPACITY															
			l/min 0	150	200	225	300	350	400	450	500	600	700	800	900	1000	1100	1200
	kW	HP	m ³ /h 0	9	12	13,5	18	21	24	27	30	36	42	48	54	60	66	72
H = TOTAL HEAD IN METRES OF COLUMN OF WATER																		
33SV2..4	1,1	1,5	17	16	15,5	15,2	13,8	12,5	10,7									
33SV3..4	1,5	2	25,7	24,5	23,8	23,3	21,4	19,4	16,9									
33SV4..4	2,2	3	34	32,2	31,2	30,6	27,9	25,3	21,8									
33SV5..4	3	4	42,7	40,6	39,4	38,6	35,3	32	27,7									
33SV6..4	3	4	51,5	49,1	47,7	46,8	42,9	39	33,9									
33SV7..4	4	5,5	59,9	57	55	54	49,5	45	38,9									
33SV8..4	5,5	7,5	69	66	64	63	58	53	46,2									
33SV9..4	5,5	7,5	77,5	74,1	72	71	65	59	51,5									
33SV10..4	5,5	7,5	85,9	82,1	80	78	72	65	56,7									
33SV11..4	7,5	10	94,9	90,8	88	87	80	73	63,5									
33SV12..4	7,5	10	103,3	98,8	96	94	87	79	68,7									
33SV13..4	7,5	10	111,8	106,8	104	102	93	85	74									
46SV2..4	1,5	2	19			17,3	16,5	16	15	13,9	12,6	8,9						
46SV3..4	2,2	3	28,8			26,5	25,4	24,4	23,1	21,5	19,5	14,4						
46SV4..4	3	4	37,9			34,6	33,1	31,6	29,8	27,6	24,8	17,7						
46SV5..4	4	5,5	47,6			43,6	41,7	40	37,7	35	31,6	22,7						
46SV6..4	5,5	7,5	57,7			53,1	51	48,9	46,3	43,1	39,1	28,6						
46SV7..4	5,5	7,5	67,1			61,7	59	57	54	49,8	45	32,7						
46SV8..4	7,5	10	77			70,9	68	65	62	58	52	38,2						
46SV9..4	7,5	10	86,4			79,4	76,1	73	69	64	58	42,4						
46SV10..4	7,5	10	95,7			87,9	84	81	76	71	64	46,5						
46SV11..4	11	15	105,7			97,1	93	89	85	79	71	52						
46SV12..4	11	15	115,3			105,9	102	97	92	86	78	57						
46SV13..4	11	15	124,9			114,8	110	106	100	93	84	61						
66SV1..4	1,5	2	10,8				9,7	9,5	9,2	8,9	8,6	7,9	7,2	6,1	4,7			
66SV2..4	3	4	21,1				19,4	19	18,5	17,9	17,4	16,0	14,5	12,5	10,1			
66SV3..4	4	5,5	31,4				29,2	28,5	27,8	27	26,2	24,2	21,7	18,9	15,4			
66SV4..4	5,5	7,5	42				39,4	38,7	37,8	36,9	35,8	33,2	30	26,1	21,3			
66SV5..4	7,5	10	52,5				49,4	48,5	47,5	46,3	44,9	41,7	37,8	32,8	26,5			
66SV6..4	7,5	10	62,7				59	58	57	55	53	49,6	44,8	38,7	31,1			
66SV7..4	11	15	73,2				68,8	67	66	64	62	58	52	45,2	36,3			
66SV8..4	11	15	83,7				78,6	77	75	73	71	66	60	52	41,5			
92SV1..4	1,5	2	11,8							9,8	9,5	8,9	8,3	7,7	7,1	6,4	5,5	4,1
92SV2..4	3	4	23,4							20	19,4	18,3	17,1	16	14,8	13,4	11,7	9,4
92SV3..4	5,5	7,5	35,4							31	30,2	28,5	26,8	25,2	23,4	21,5	19	15,9
92SV4..4	7,5	10	47,2							41,4	40,3	38	35,8	33,6	31,2	28,6	25,4	21,3
92SV5..4	7,5	10	58,5							51,2	50	46,9	44,1	41,4	38,4	35,1	31,1	25,8
92SV6..4	11	15	70,2							61,4	60	56	53	50	46,1	42,1	37,3	30,9
92SV7..4	11	15	81,9							71,6	70	66	62	58	54	49	43,5	36,1
92SV8..4	15	20	93,6							81,8	80	75	71	66	62	56	50	41,2

Performances in compliance with ISO 9906 - Annex A.

33-92sv-4p60-en_a_th

PUMP TYPE	RATED POWER		Q = DELIVERY															
			l/min 0	250	300	375	450	500	650	750	850	1000	1200	1300	1400	1500		
	kW	HP	m ³ /h 0	15,0	18,0	22,5	27,0	30,0	39,0	45,0	51,0	60,0	72,0	78,0	84,0	90,0		
H = TOTAL HEAD IN METRES OF COLUMN OF WATER																		
125SV1..4	2,2	3	10,0					7,9	7,4	7,1	6,8	6,2	5,3	4,7	4,0	3,2		
125SV2/2A..4	3	4	18,3					15,4	14,6	14,1	13,5	12,4	10,6	9,6	8,4	7,0		
125SV3/3B..4	4	5,5	25,5					21,3	20,1	19,3	18,3	16,7	13,9	12,2	10,3	8,0		
125SV4/4A..4	5,5	7,5	36,5					30,9	29,3	28,1	26,9	24,8	21,3	19,2	16,8	14,1		
125SV5/5A..4	7,5	10	45,6					38,6	36,6	35,2	33,6	31,0	26,6	24,0	21,0	17,6		
125SV6..4	11	15	58,7					50,1	47,7	46,0	44,2	41,1	36,1	33,2	29,8	26,1		
125SV7..4	11	15	68,5					58,4	55,6	53,7	51,5	48,0	42,2	38,7	34,8	30,4		
125SV8..4	15	20,5	78,3					66,8	63,6	61,3	58,9	54,8	48,2	44,2	39,8	34,8		

Performances in compliance with ISO 9906 - Annex A.

125sv-4p60-en_b_th

 4-POLE
(60 Hz)

1SV SERIES
DIMENSIONS AND WEIGHTS AT 60 Hz, 4-POLE

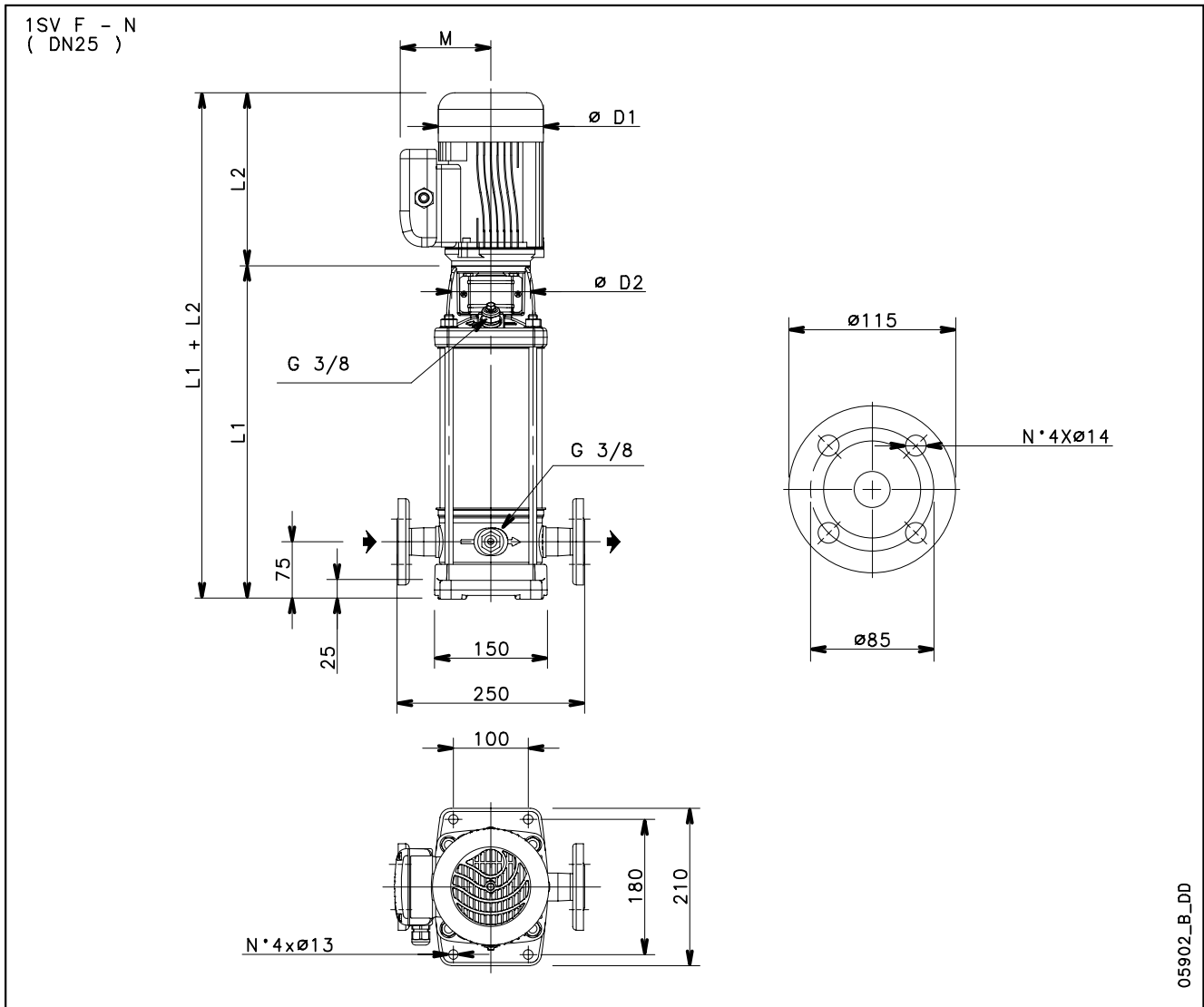

05902_B_DD

PUMP TYPE	MOTOR		DIMENSIONS (mm)					WEIGHT kg	
	kW	SIZE	L1	L2	D1	D2	M	PUMP	ELECTRIC PUMP
1SV03..4	0,25	71	278	231	140	105	121	8,6	15,4
1SV05..4	0,25	71	318	231	140	105	121	9,4	16,2
1SV07..4	0,25	71	358	231	140	105	121	10,2	17
1SV09..4	0,25	71	398	231	140	105	121	11	17,8
1SV11..4	0,25	71	438	231	140	105	121	11,8	18,6
1SV13..4	0,25	71	478	231	140	105	121	12,6	19,4
1SV15..4	0,25	71	518	231	140	105	121	13,4	20,2
1SV17..4	0,25	71	558	231	140	105	121	14,2	21
1SV18..4	0,25	71	578	231	140	105	121	14,6	21,4
1SV20..4	0,25	71	618	231	140	105	121	15,4	22,2
1SV22..4	0,25	71	658	231	140	105	121	16,2	23
1SV24..4	0,25	71	698	231	140	105	121	17	23,8
1SV26..4	0,37	71	738	231	140	105	121	17,8	25,8
1SV28..4	0,37	71	778	231	140	105	121	18,6	26,6

1sv-4p60-en_a_td

**4-POLE
(60 Hz)**

**1SV SERIES
OPERATING CHARACTERISTICS AT 60 Hz, 4-POLE**

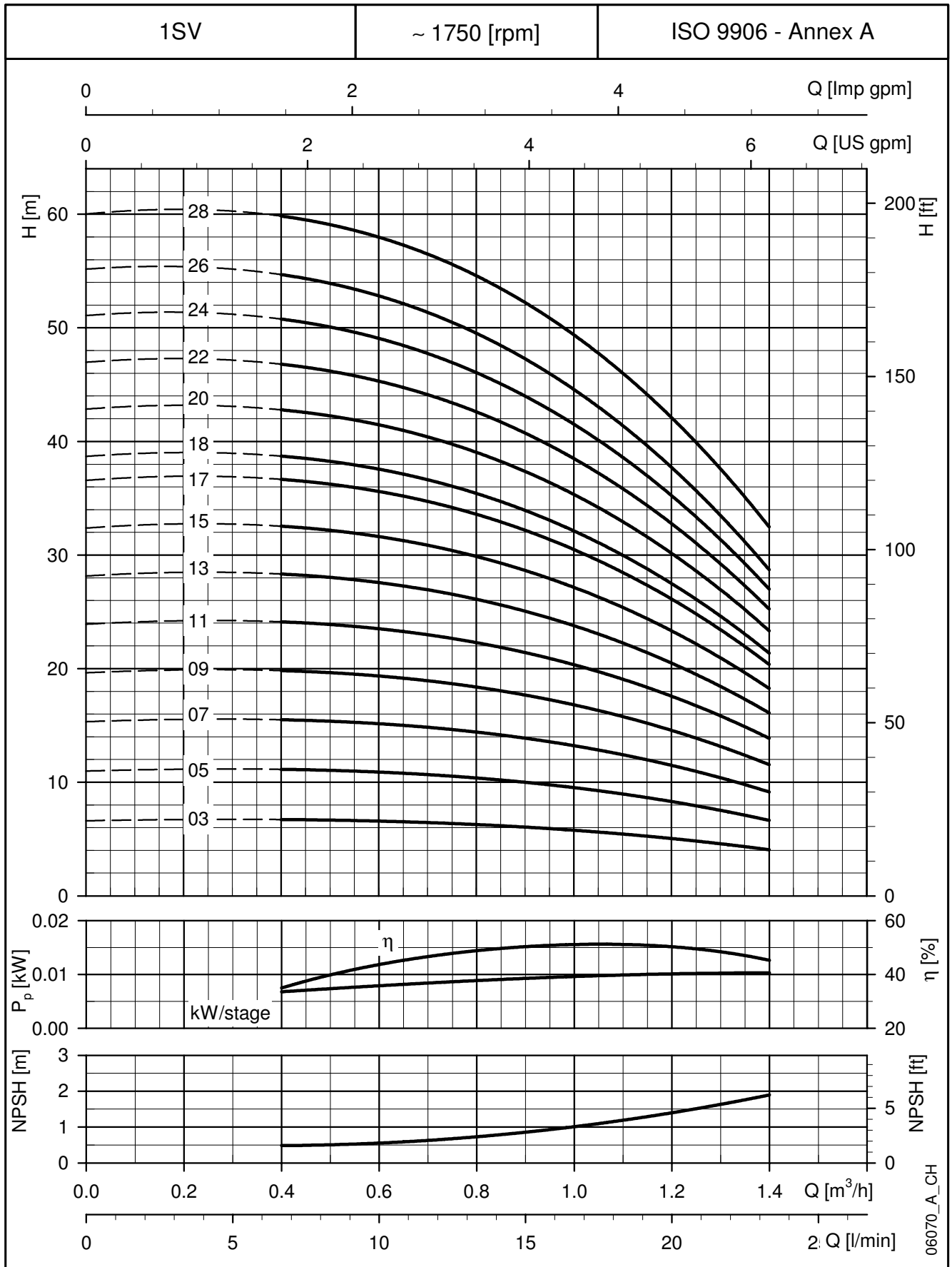

These performances are valid for liquids with density $\rho = 1.0 \text{ Kg/dm}^3$ and kinematic viscosity $\nu = 1 \text{ mm}^2/\text{sec}$.

3SV SERIES DIMENSIONS AND WEIGHTS AT 60 Hz, 4-POLE

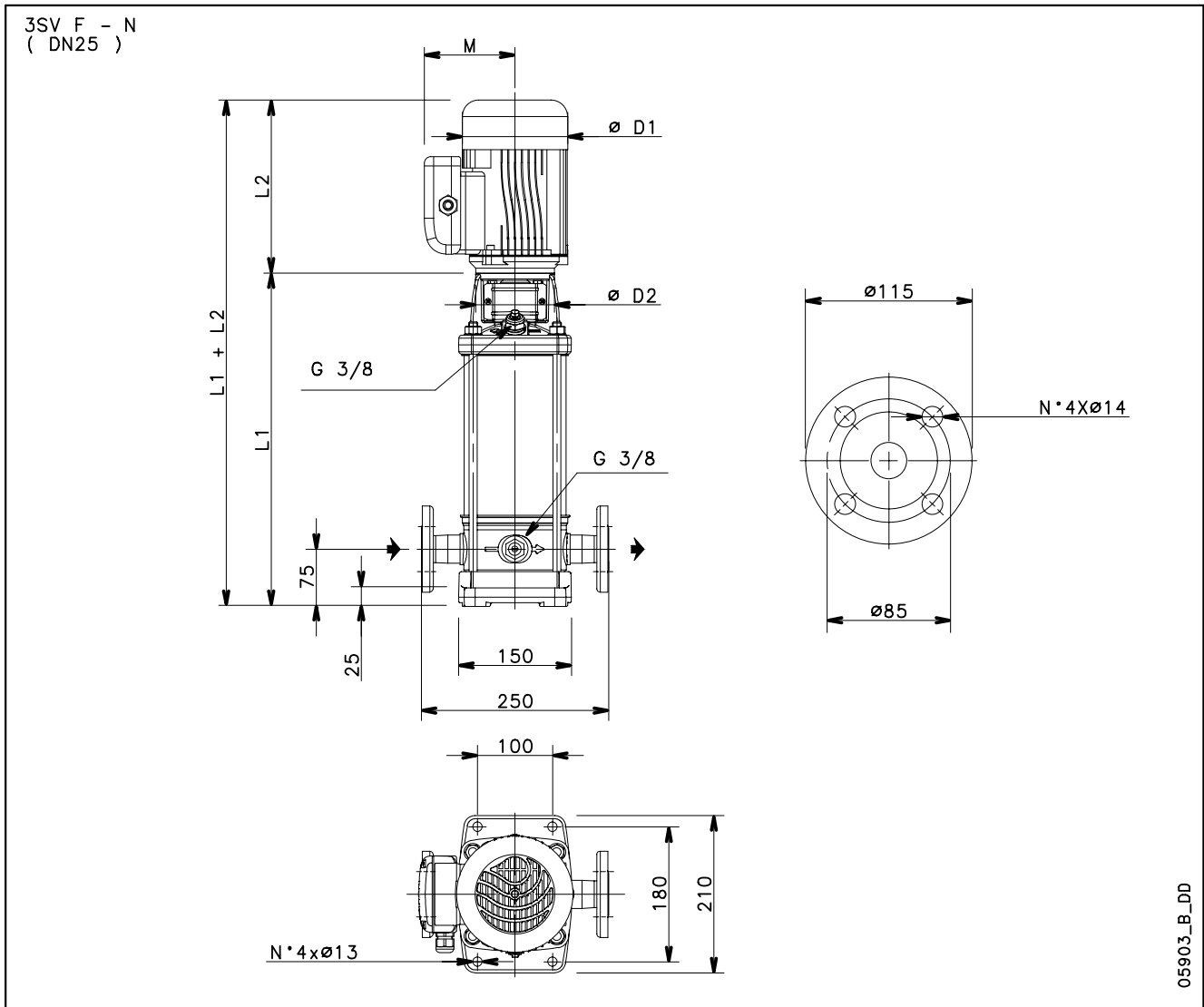

**4-POLE
(60 Hz)**

PUMP TYPE	MOTOR		DIMENSIONS (mm)					WEIGHT kg	
	kW	SIZE	L1	L2	D1	D2	M	PUMP	ELECTRIC PUMP
3SV02..4..	0,25	71	278	231	140	105	121	8	14,8
3SV04..4..	0,25	71	298	231	140	105	121	8,8	15,6
3SV06..4..	0,25	71	338	231	140	105	121	9,7	16,5
3SV08..4..	0,25	71	378	231	140	105	121	10,5	17,3
3SV10..4..	0,25	71	418	231	140	105	121	11,3	18,1
3SV12..4..	0,25	71	458	231	140	105	121	12,1	18,9
3SV14..4..	0,37	71	498	231	140	105	121	12,9	20,9
3SV15..4..	0,37	71	518	231	140	105	121	13,3	21,3
3SV17..4..	0,37	71	558	231	140	105	121	14,1	22,1
3SV19..4..	0,37	71	598	231	140	105	121	14,9	22,9
3SV21..4..	0,55	80	648	263	155	120	129	15,7	22,4
3SV23..4..	0,55	80	688	263	155	120	129	16,5	23,2

**3SV SERIES
OPERATING CHARACTERISTICS AT 60 Hz, 4-POLE**

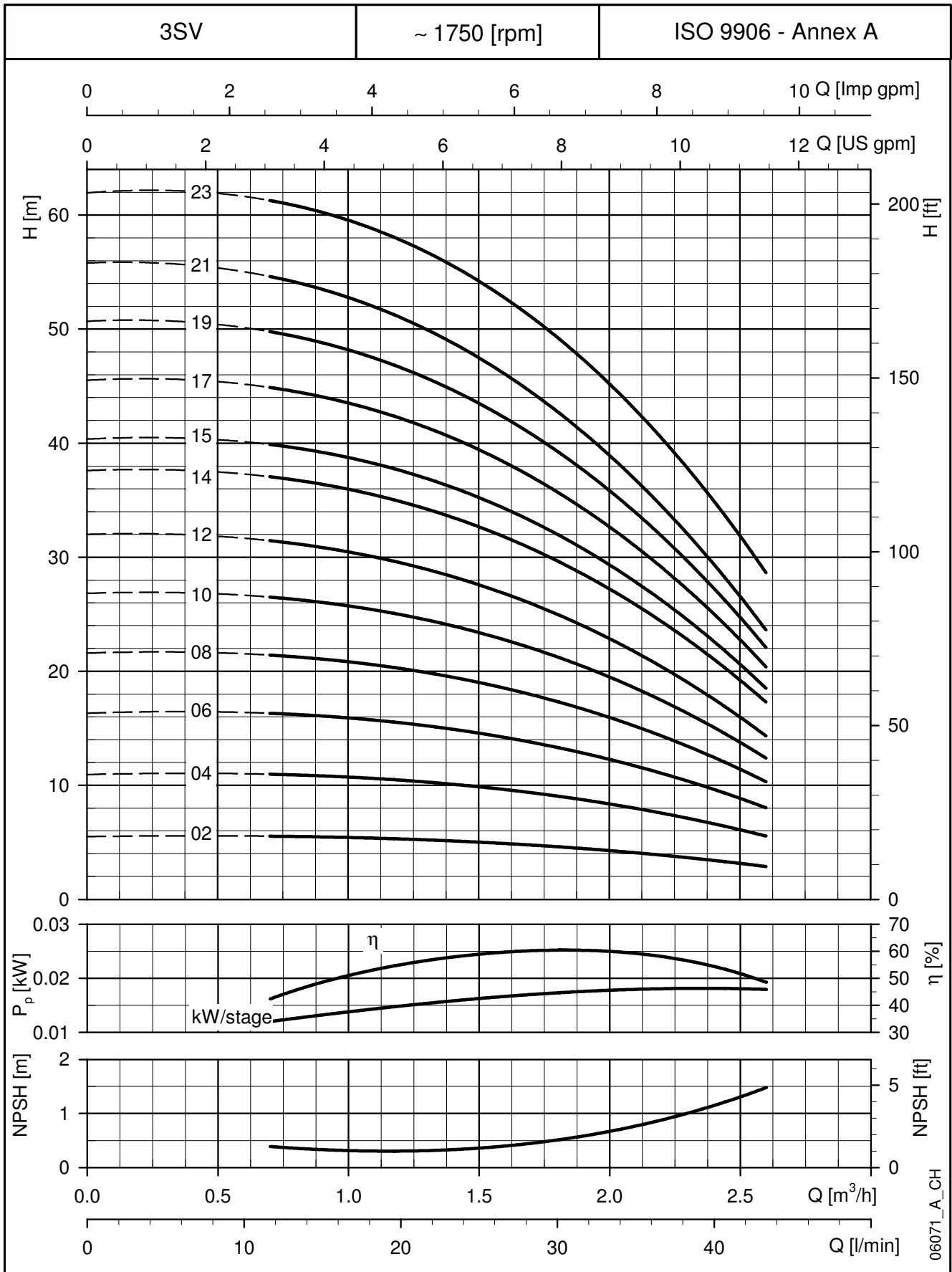

These performances are valid for liquids with density $\rho = 1.0 \text{ Kg/dm}^3$ and kinematic viscosity $\nu = 1 \text{ mm}^2/\text{sec}$.

5SV SERIES

DIMENSIONS AND WEIGHTS AT 60 Hz, 4-POLE

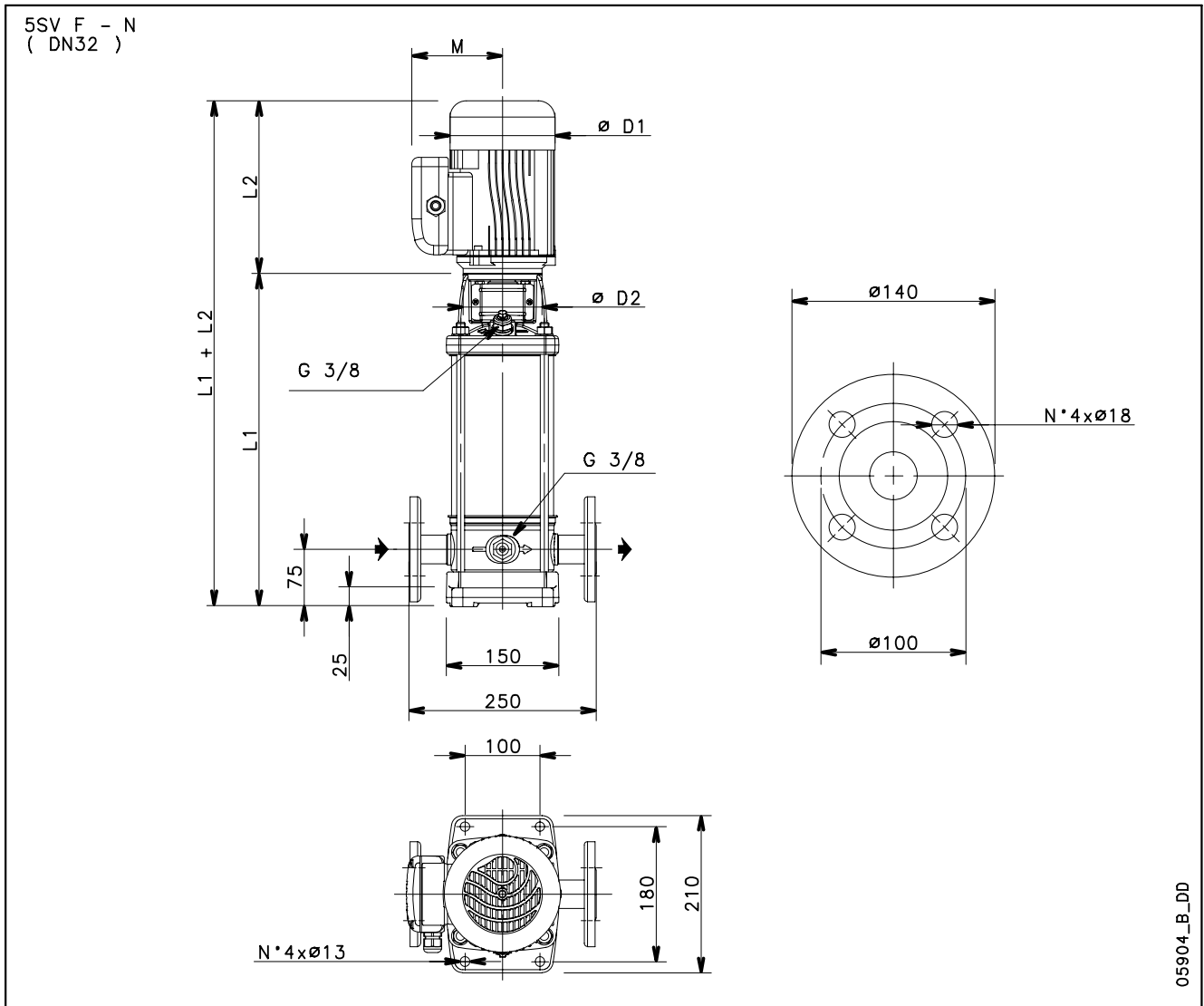

PUMP TYPE	MOTOR		DIMENSIONS (mm)					WEIGHT kg	
	kW	SIZE	L1	L2	D1	D2	M	PUMP	ELECTRIC PUMP
5SV03..4..	0,25	71	293	231	140	105	121	8,9	15,7
5SV05..4..	0,25	71	343	231	140	105	121	9,9	16,7
5SV07..4..	0,25	71	393	231	140	105	121	10,8	17,6
5SV09..4..	0,37	71	443	231	140	105	121	11,8	19,8
5SV11..4..	0,37	71	493	231	140	105	121	12,8	20,8
5SV13..4..	0,55	80	553	263	155	120	129	14,1	20,8
5SV15..4..	0,55	80	603	263	155	120	129	15	21,7
5SV17..4..	0,55	80	653	263	155	120	129	15	22,7
5SV19..4..	0,75	80	703	231	159	120	128	16,9	29
5SV21..4..	0,75	80	753	231	159	120	128	17,9	30
5SV23..4..	0,75	80	803	231	159	120	128	18,8	31

**4-POLE
(60 Hz)**

**5SV SERIES
OPERATING CHARACTERISTICS AT 60 Hz, 4-POLE**

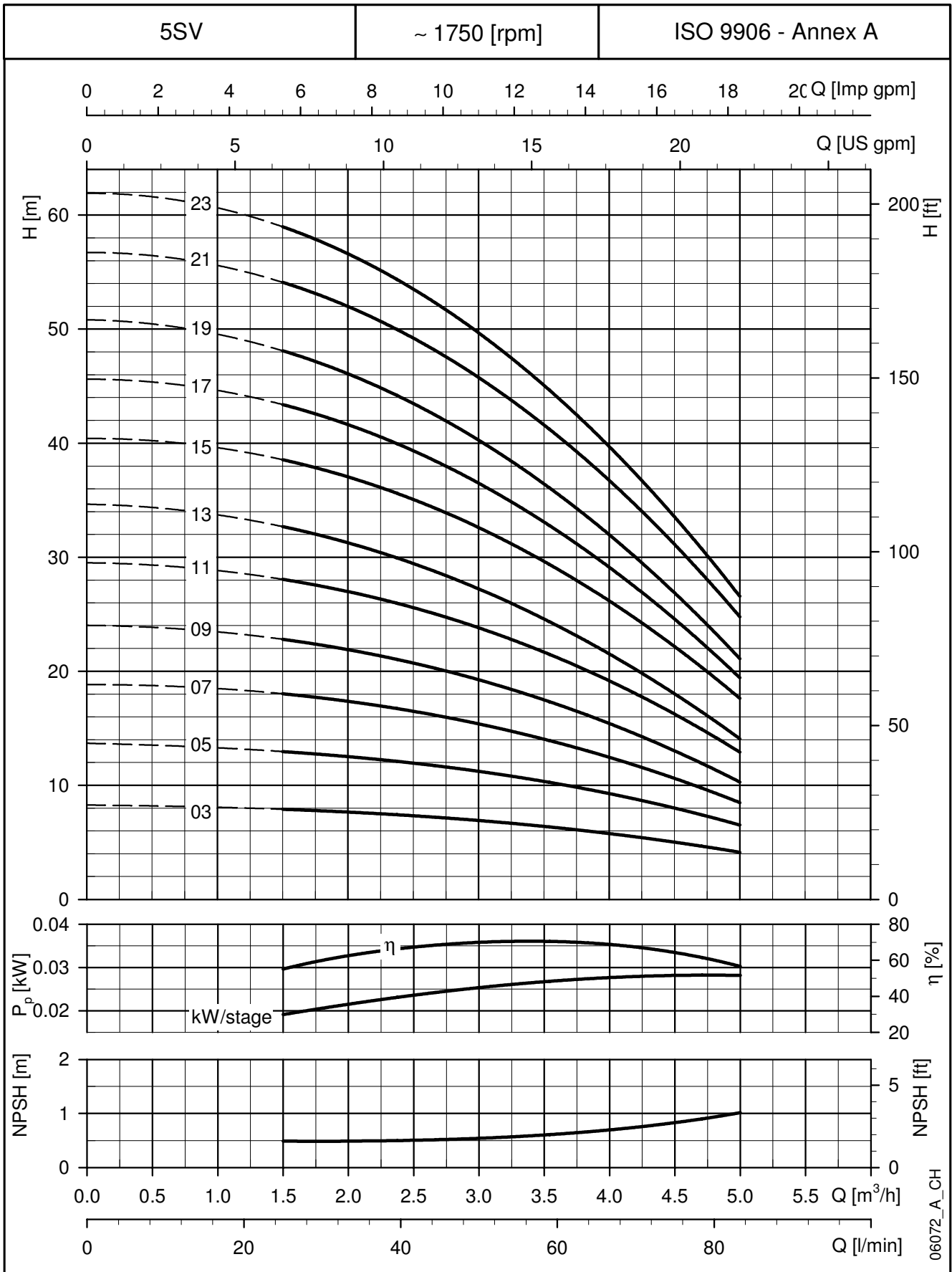

**4-POLE
(60 Hz)**

These performances are valid for liquids with density $\rho = 1.0 \text{ Kg/dm}^3$ and kinematic viscosity $\nu = 1 \text{ mm}^2/\text{sec}$.

10SV SERIES
DIMENSIONS AND WEIGHTS AT 60 Hz, 4-POLE

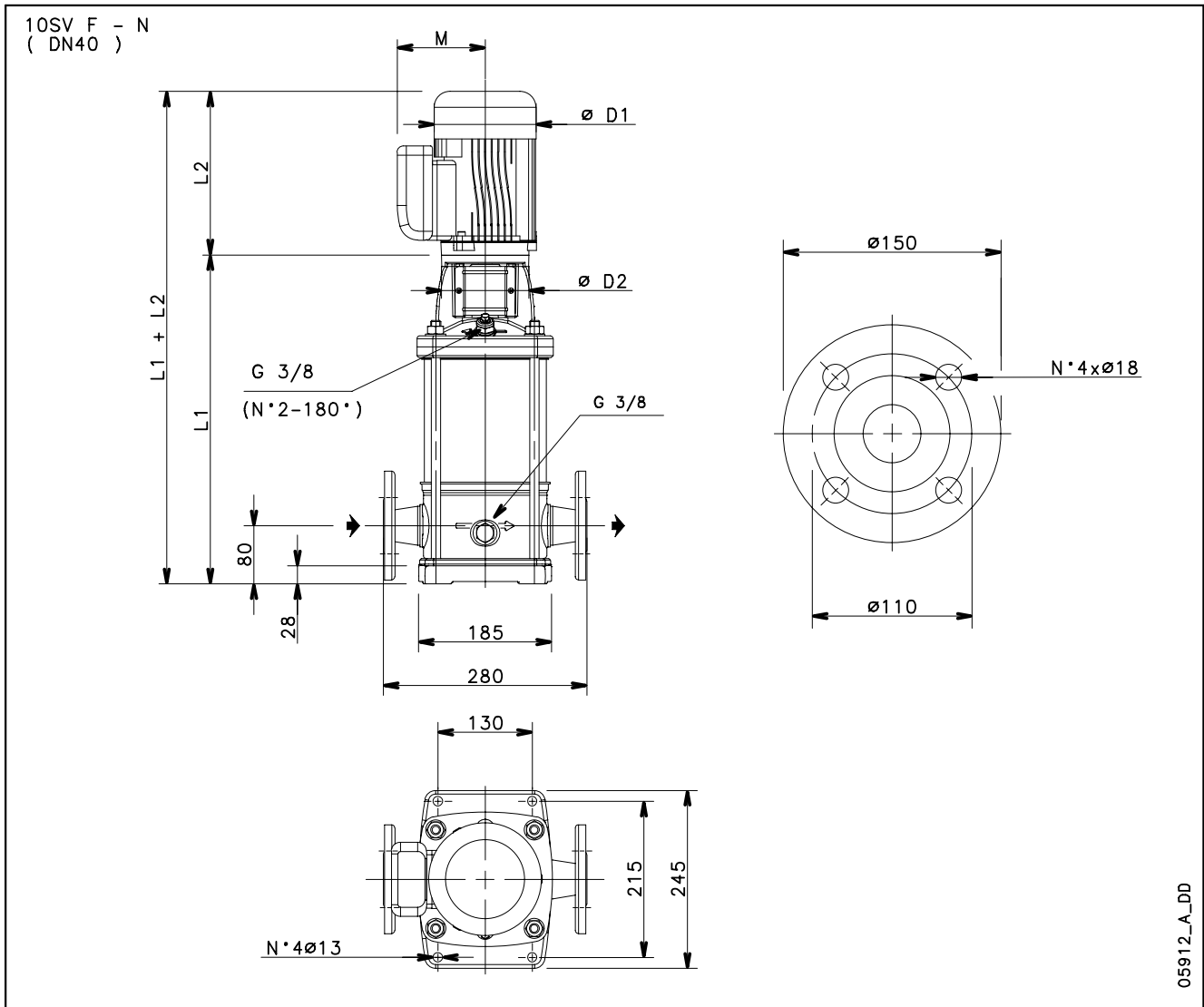

**4-POLE
(60 Hz)**

PUMP TYPE	MOTOR		DIMENSIONS (mm)					WEIGHT kg	
	kW	SIZE	L1	L2	D1	D2	M	PUMP	ELECTRIC PUMP
10SV03..4..	0,55	80	389	263	155	120	129	16,1	22,8
10SV05..4..	0,55	80	453	263	155	120	129	18	24,7
10SV07..4..	0,75	80	517	231	159	120	128	19,9	32
10SV09..4..	0,75	80	581	231	159	120	128	21,7	33,8
10SV11..4..	1,1	90	655	298	174	140	134	24	41,4
10SV13..4..	1,1	90	719	298	174	140	134	25,8	43,2
10SV15..4..	1,5	90	783	298	174	140	134	27,7	47,7

**10SV SERIES
OPERATING CHARACTERISTICS AT 60 Hz, 4-POLE**

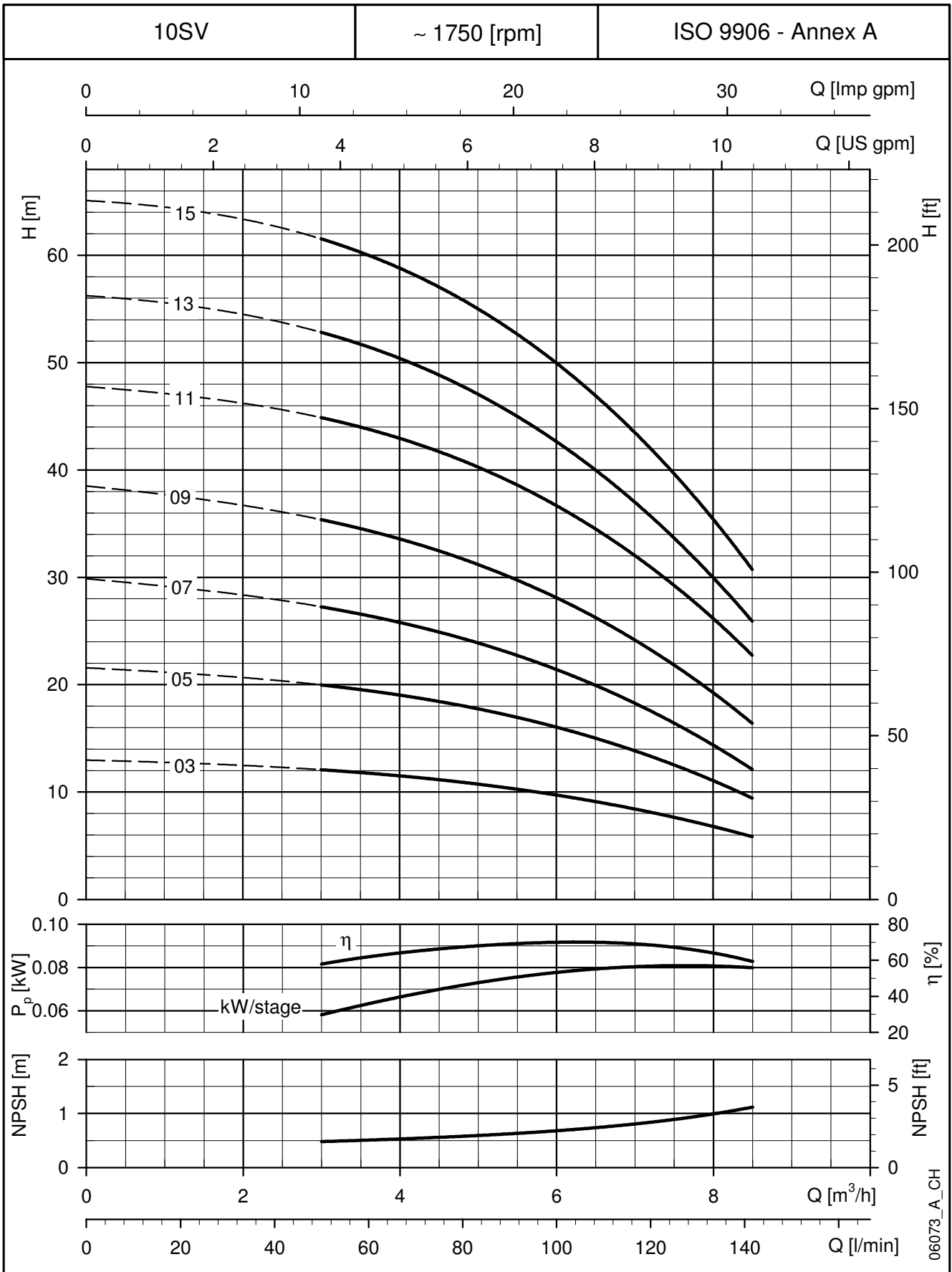

**4-POLE
(60 Hz)**

These performances are valid for liquids with density $\rho = 1.0 \text{ Kg/dm}^3$ and kinematic viscosity $\nu = 1 \text{ mm}^2/\text{sec}$.

15SV SERIES
DIMENSIONS AND WEIGHTS AT 60 Hz, 4-POLE

15SV F - N
(DN50)

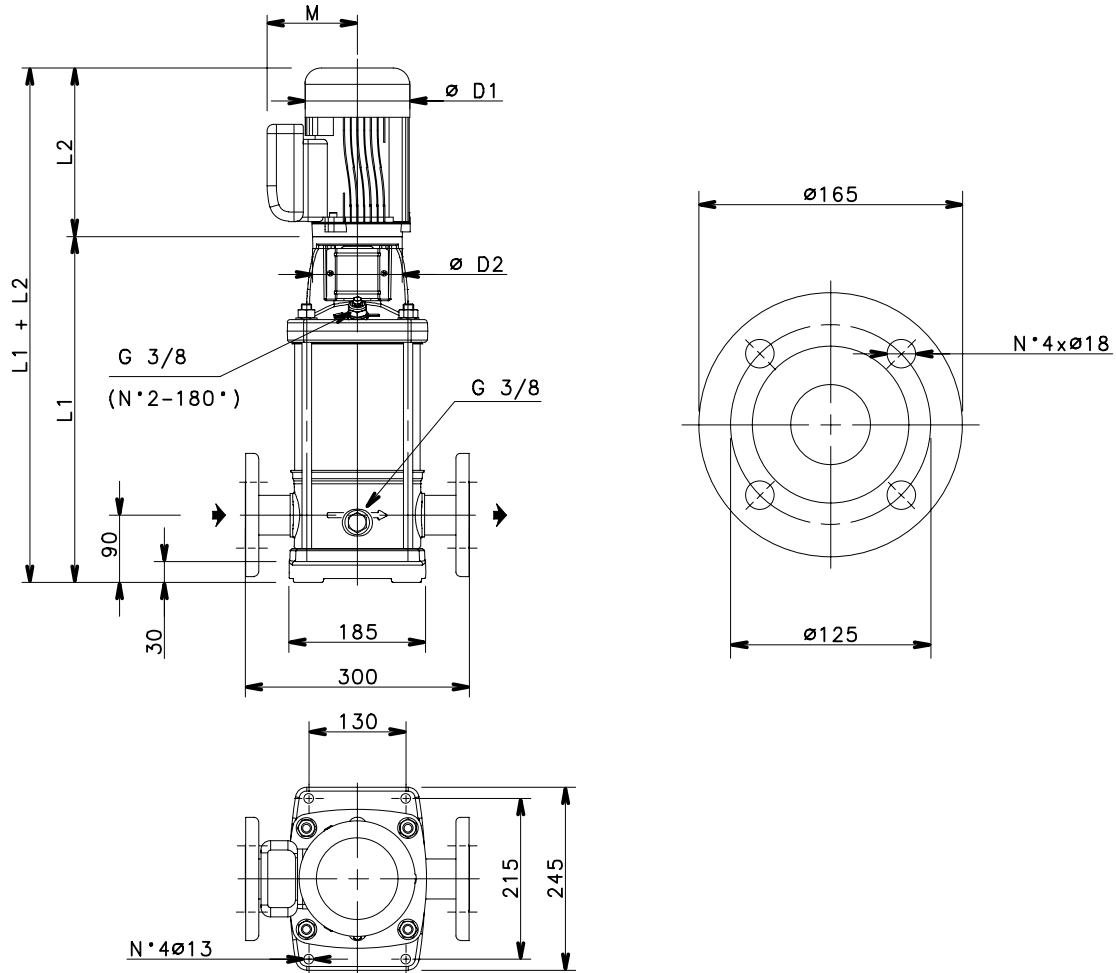

05913_A_DD

**4-POLE
(60 Hz)**

PUMP TYPE	MOTOR		DIMENSIONS (mm)					WEIGHT kg	
	kW	SIZE	L1	L2	D1	D2	M	PUMP	ELECTRIC PUMP
15SV03..4..	0,55	80	447	263	155	120	129	17,9	24,6
15SV04..4..	0,75	80	495	231	159	120	128	19,3	31,4
15SV05..4..	1,1	90	553	298	174	140	134	21,1	38,5
15SV06..4..	1,1	90	601	298	174	140	134	22,5	39,9
15SV07..4..	1,5	90	649	298	174	140	134	23,8	43,8
15SV08..4..	1,5	90	697	298	174	140	134	25,2	45,2
15SV09..4..	2,2	100	755	322	214	160	168	27,4	56,2
15SV10..4..	2,2	100	803	322	214	160	168	28,7	57,5
15SV11..4..	2,2	100	851	322	214	160	168	30	58,8
15SV12..4..	2,2	100	899	322	214	160	168	31,4	60,2

**15SV SERIES
OPERATING CHARACTERISTICS AT 60 Hz, 4-POLE**

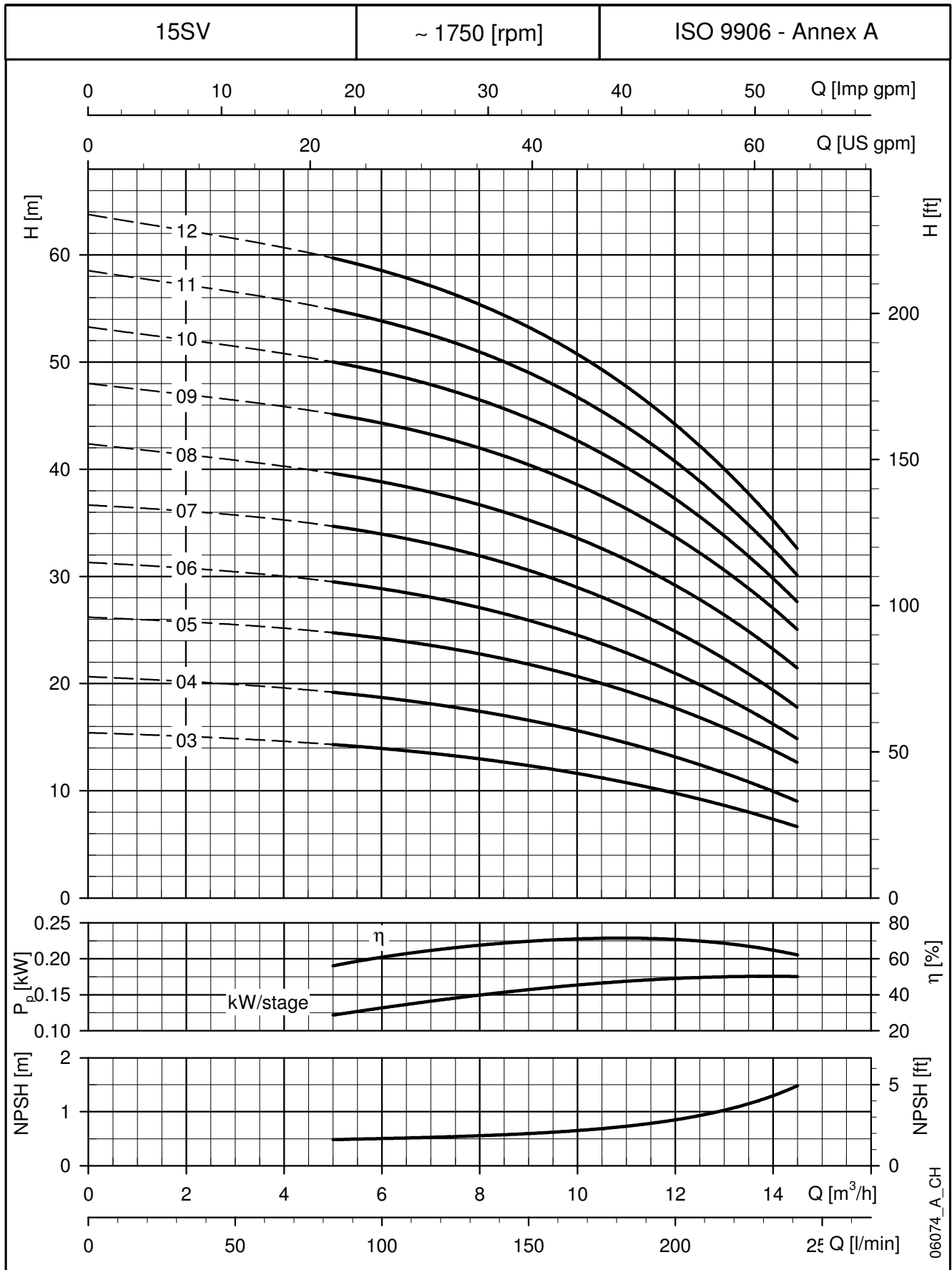

**4-POLE
(60 Hz)**

These performances are valid for liquids with density $\rho = 1.0 \text{ Kg/dm}^3$ and kinematic viscosity $\nu = 1 \text{ mm}^2/\text{sec}$.

22SV SERIES
DIMENSIONS AND WEIGHTS AT 60 Hz, 4-POLE

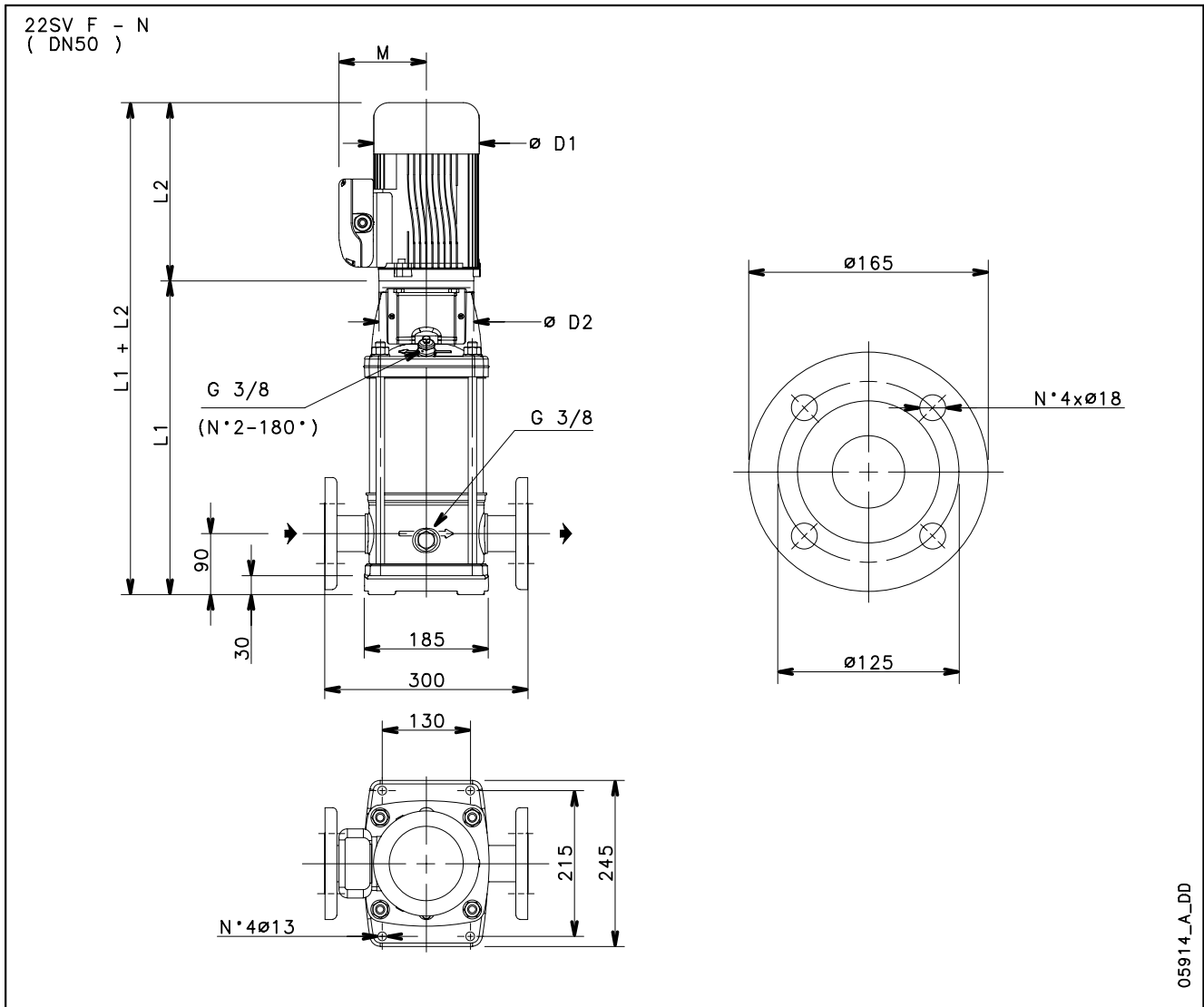

**4-POLE
(60 Hz)**

PUMP TYPE	MOTOR		DIMENSIONS (mm)					WEIGHT kg	
	kW	SIZE	L1	L2	D1	D2	M	PUMP	ELECTRIC PUMP
22SV02..4..	0,55	80	399	263	155	120	129	16,9	23,6
22SV03..4..	0,75	80	447	231	159	120	128	18,2	30,3
22SV04..4..	1,1	90	505	298	174	140	134	19,8	37,2
22SV05..4..	1,5	90	553	298	174	140	134	21	41
22SV06..4..	1,5	90	601	298	174	140	134	22,4	42,4
22SV07..4..	2,2	100	659	322	214	160	168	24,6	53,4
22SV08..4..	2,2	100	707	322	214	160	168	25,9	54,7
22SV09..4..	2,2	100	755	322	214	160	168	27,2	56
22SV10..4..	3	100	803	353	214	160	168	28,6	60,6

**22SV SERIES
OPERATING CHARACTERISTICS AT 60 Hz, 4-POLE**

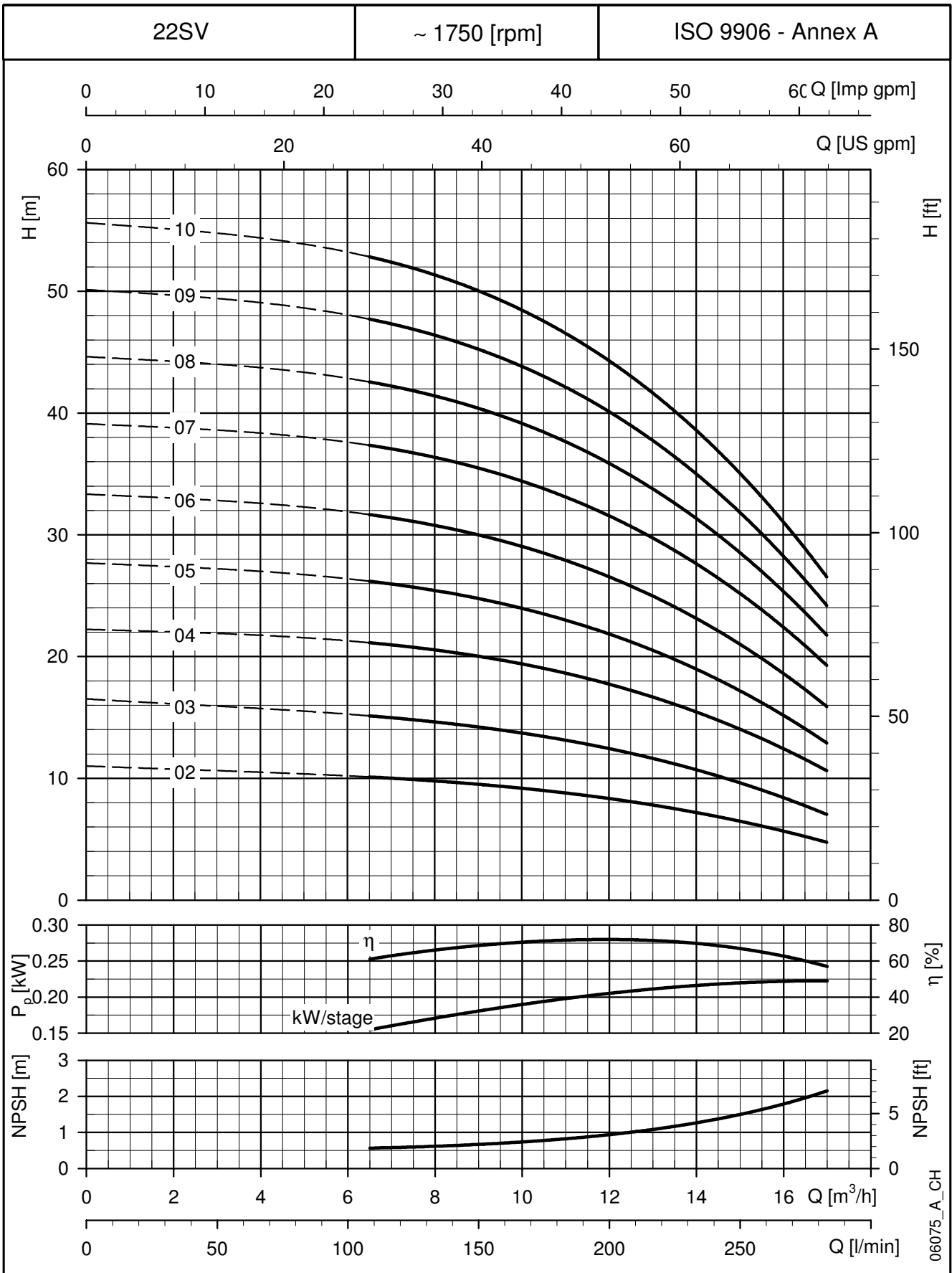

These performances are valid for liquids with density $\rho = 1.0 \text{ Kg/dm}^3$ and kinematic viscosity $\nu = 1 \text{ mm}^2/\text{sec}$.

33SV SERIES DIMENSIONS AND WEIGHTS AT 60 Hz, 4-POLE

33SV G - N
(DN65)

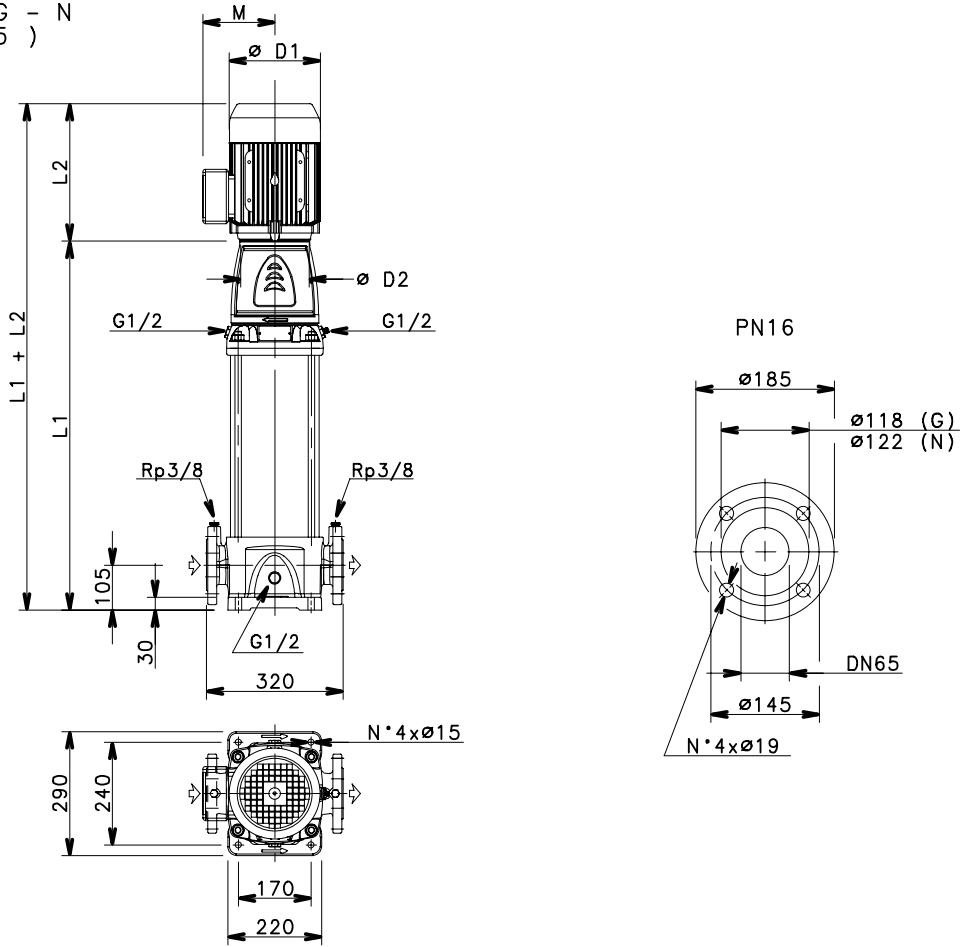

05125_D_DD

PUMP TYPE	MOTOR		DIMENSIONS (mm)						WEIGHT kg	
	kW	SIZE	L1	L2	D1	D2	M	PN	PUMP	ELECTRIC PUMP
33SV2..4..	1,1	90	564	298	174	164	134	16	56	74
33SV3..4..	1,5	90	639	298	174	164	134	16	60	83
33SV4..4..	2,2	100	714	322	214	164	168	16	64	93
33SV5..4..	3	100	789	353	214	164	168	16	68	100
33SV6..4..	3	100	864	353	214	164	168	16	72	104
33SV7..4..	4	112	939	398	214	164	168	16	75	129
33SV8..4..	5,5	132	1034	405	256	300	191	16	84	146
33SV9..4..	5,5	132	1109	405	256	300	191	16	88	150
33SV10..4..	5,5	132	1184	405	256	300	191	16	92	154
33SV11..4..	7,5	132	1259	405	256	300	191	16	101	168
33SV12..4..	7,5	132	1334	405	256	300	191	16	105	172
33SV13..4..	7,5	132	1409	405	256	300	191	16	109	176

33sv-4p60-en_b_td

4-POLE
(60 Hz)

**33SV SERIES
OPERATING CHARACTERISTICS AT 60 Hz, 4-POLE**

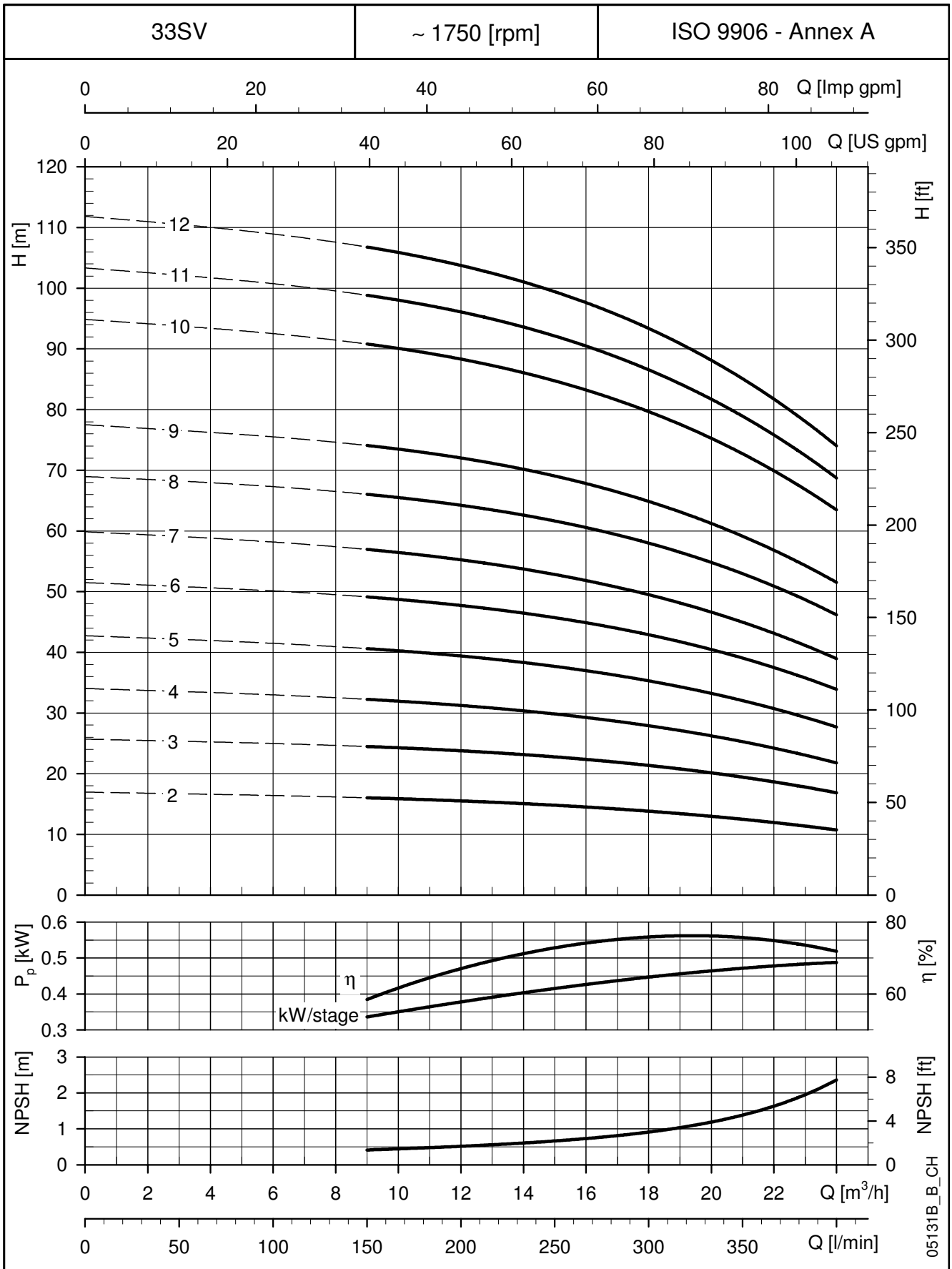

**4-POLE
(60 Hz)**

These performances are valid for liquids with density $\rho = 1.0 \text{ Kg/dm}^3$ and kinematic viscosity $\nu = 1 \text{ mm}^2/\text{sec}$.

46SV SERIES
DIMENSIONS AND WEIGHTS AT 60 Hz, 4-POLE

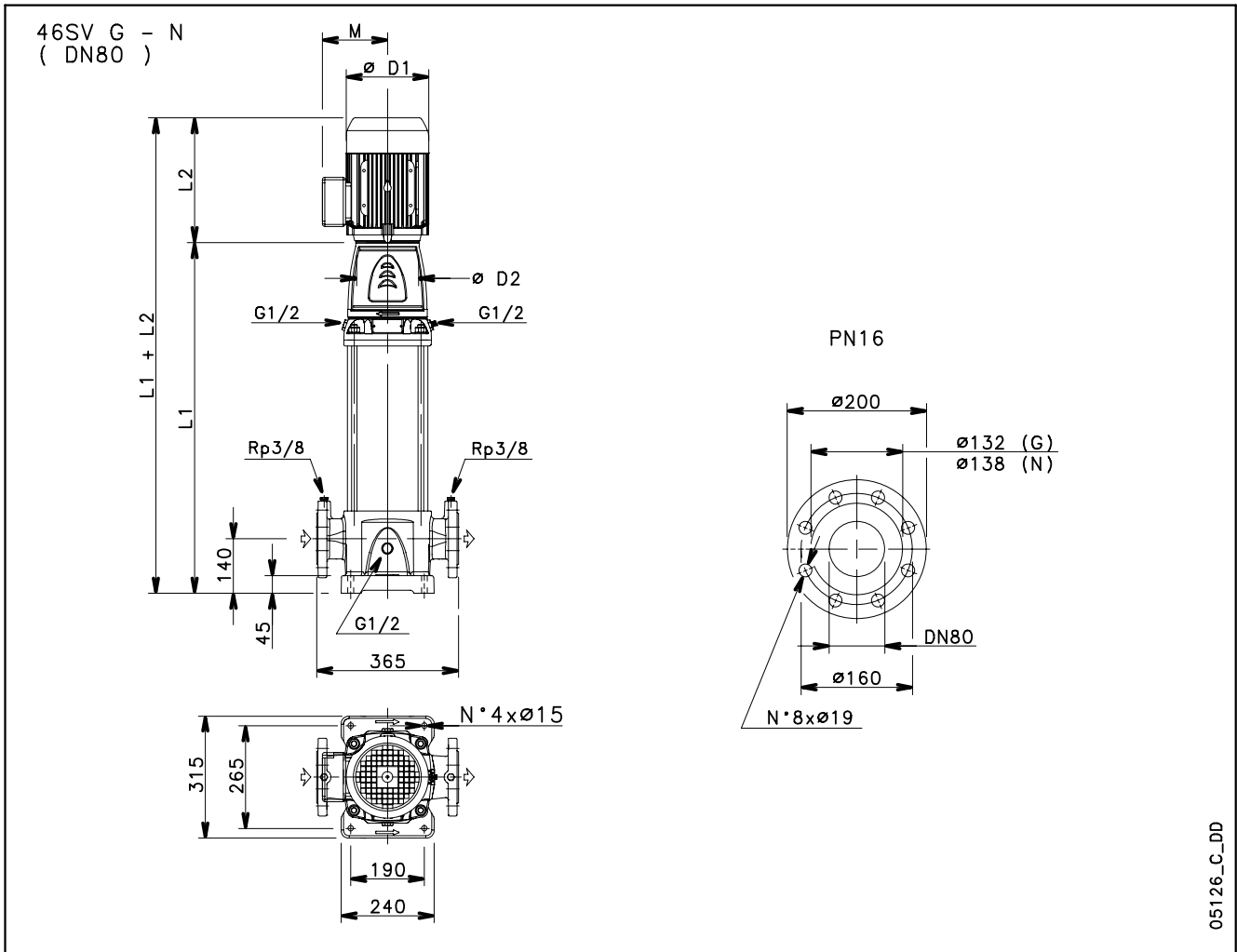

05126_C_DD

PUMP TYPE	MOTOR		DIMENSIONS (mm)						WEIGHT kg	
	kW	SIZE	L1	L2	D1	D2	M	PN	PUMP	ELECTRIC PUMP
46SV2..4..	1,5	90	604	298	174	164	134	16	61	84
46SV3..4..	2,2	100	679	322	214	164	168	16	65	94
46SV4..4..	3	100	754	353	214	164	168	16	69	101
46SV5..4..	4	112	829	398	214	164	168	16	73	127
46SV6..4..	5,5	132	924	405	256	300	191	16	82	144
46SV7..4..	5,5	132	999	405	256	300	191	16	85	147
46SV8..4..	7,5	132	1074	405	256	300	191	16	89	156
46SV9..4..	7,5	132	1149	405	256	300	191	16	93	160
46SV10..4..	7,5	132	1224	405	256	300	191	16	97	164
46SV11..4..	11	160	1334	494	313	350	240	16	109	235
46SV12..4..	11	160	1409	494	313	350	240	16	113	239
46SV13..4..	11	160	1484	494	313	350	240	16	117	243

4-POLE
(60 Hz)

**46SV SERIES
OPERATING CHARACTERISTICS AT 60 Hz, 4-POLE**

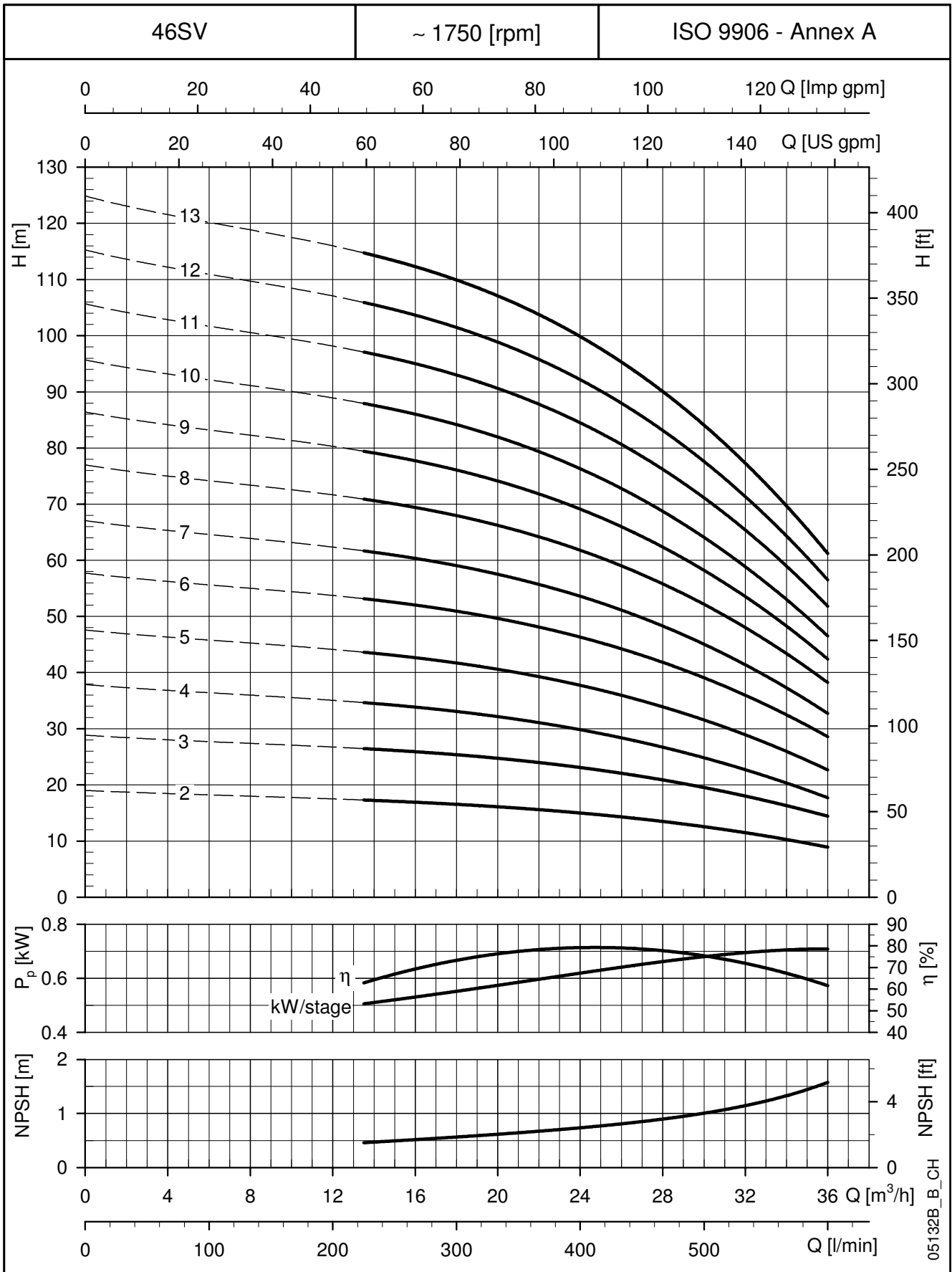

**4-POLE
(60 Hz)**

These performances are valid for liquids with density $\rho = 1.0 \text{ Kg/dm}^3$ and kinematic viscosity $\nu = 1 \text{ mm}^2/\text{sec}$.

66SV SERIES
DIMENSIONS AND WEIGHTS AT 60 Hz, 4-POLE

66SV G - N
(DN100)

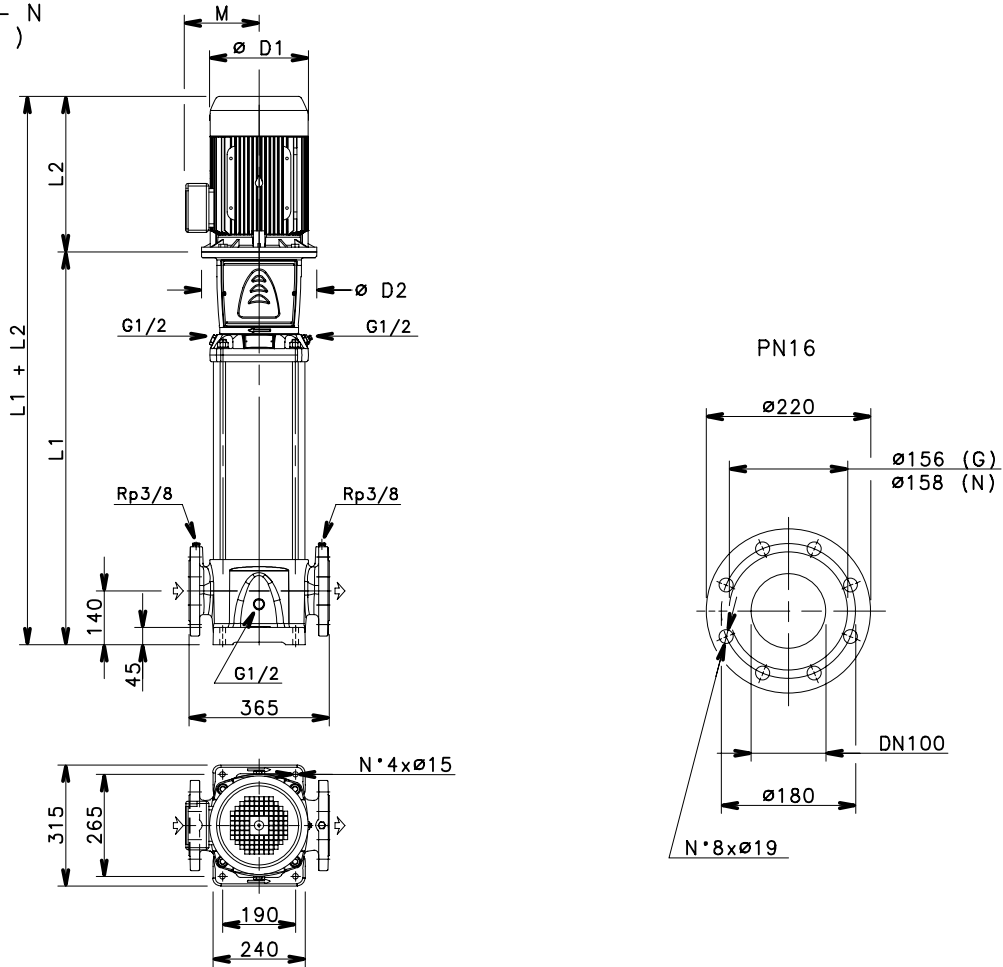

05127_C_DD

4-POLE
(60 Hz)

PUMP TYPE	MOTOR		DIMENSIONS (mm)						WEIGHT kg	
	kW	SIZE	L1	L2	D1	D2	M	PN	PUMP	ELECTRIC PUMP
66SV1..4..	1,5	90	554	298	174	164	134	16	66	89
66SV2..4..	3	100	644	353	214	164	168	16	72	104
66SV3..4..	4	112	734	398	214	164	168	16	77	131
66SV4..4..	5,5	132	844	405	256	300	191	16	87	149
66SV5..4..	7,5	132	934	405	256	300	191	16	92	159
66SV6..4..	7,5	132	1024	405	256	300	191	16	98	165
66SV7..4..	11	160	1149	494	313	350	240	16	107	233
66SV8..4..	11	160	1239	494	313	350	240	16	112	238

**66SV SERIES
OPERATING CHARACTERISTICS AT 60 Hz, 4-POLE**

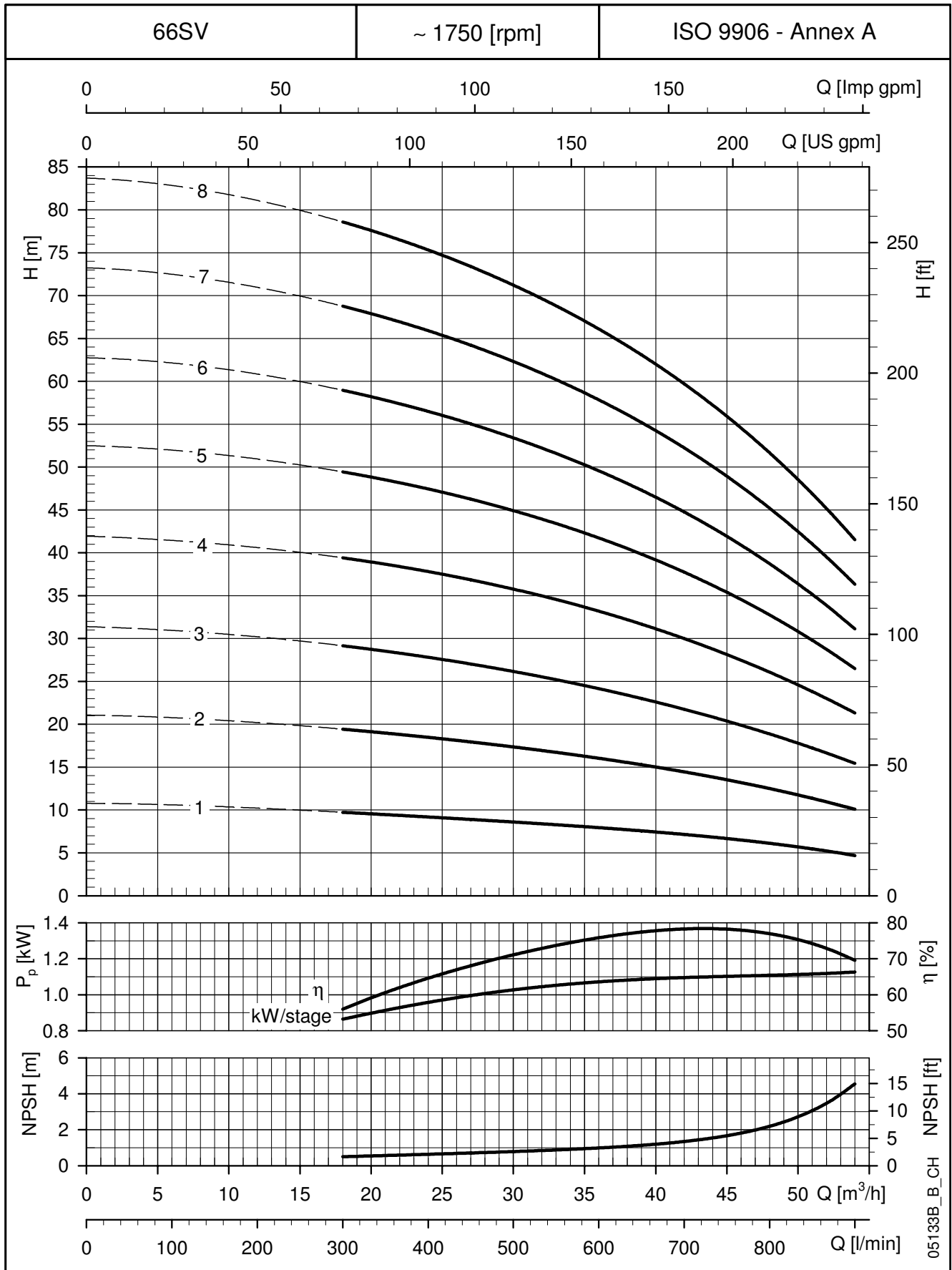

**4-POLE
(60 Hz)**

These performances are valid for liquids with density $\rho = 1.0 \text{ Kg/dm}^3$ and kinematic viscosity $\nu = 1 \text{ mm}^2/\text{sec}$.

92SV SERIES
DIMENSIONS AND WEIGHTS AT 60 Hz, 4-POLE

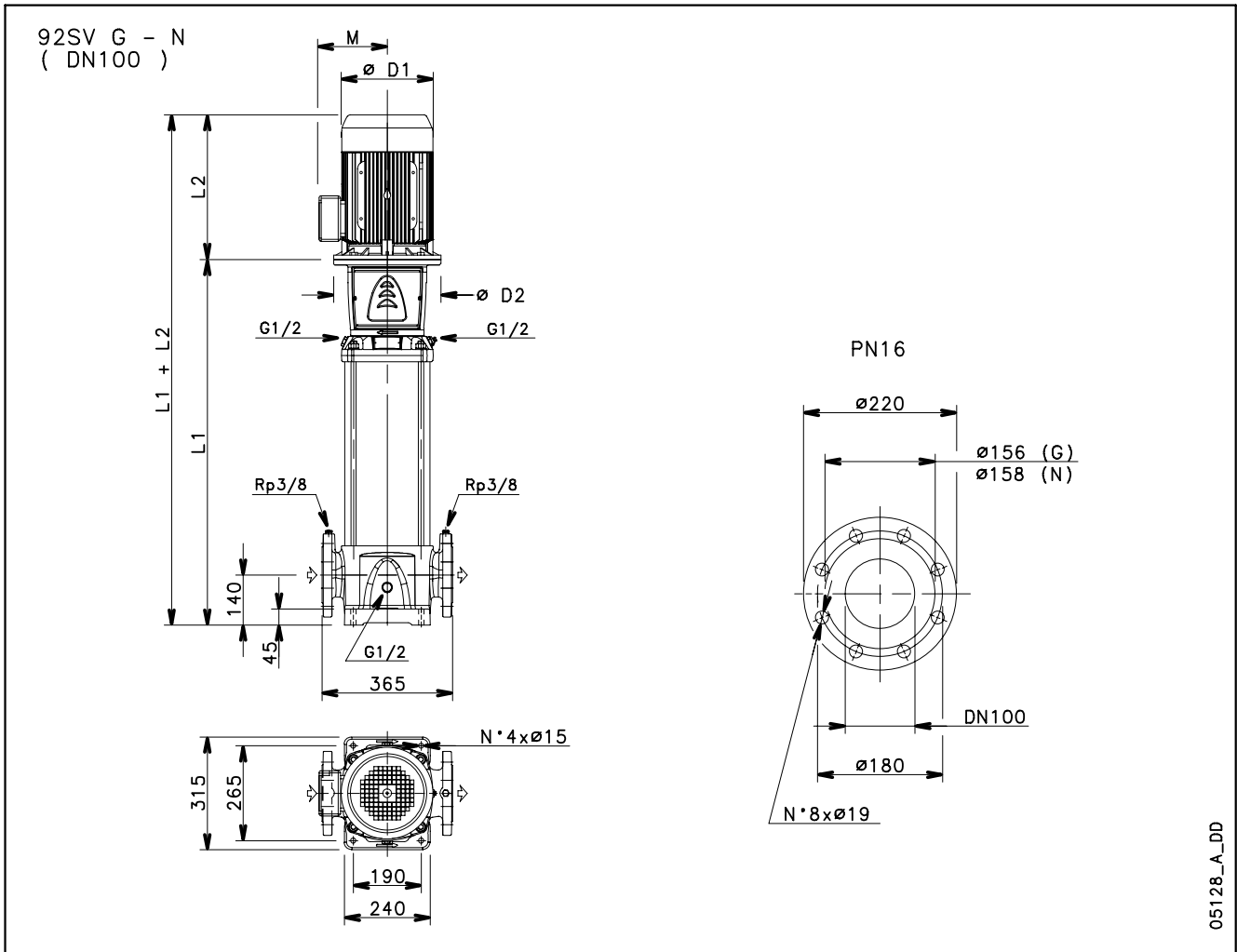

4-POLE
(60 Hz)

PUMP TYPE	MOTOR		DIMENSIONS (mm)						WEIGHT kg	
	kW	SIZE	L1	L2	D1	D2	M	PN	PUMP	ELECTRIC PUMP
92SV1..4..	1,5	90	554	298	174	164	134	16	66	89
92SV2..4..	3	100	644	353	214	164	168	16	71	103
92SV3..4..	5,5	132	754	405	256	300	191	16	82	144
92SV4..4..	7,5	132	844	405	256	300	191	16	87	154
92SV5..4..	7,5	132	934	405	256	300	191	16	92	159
92SV6..4..	11	160	1059	494	313	350	240	16	101	227
92SV7..4..	11	160	1149	494	313	350	240	16	106	232
92SV8..4..	15	160	1239	494	313	350	240	16	111	240

**92SV SERIES
OPERATING CHARACTERISTICS AT 60 Hz, 4-POLE**

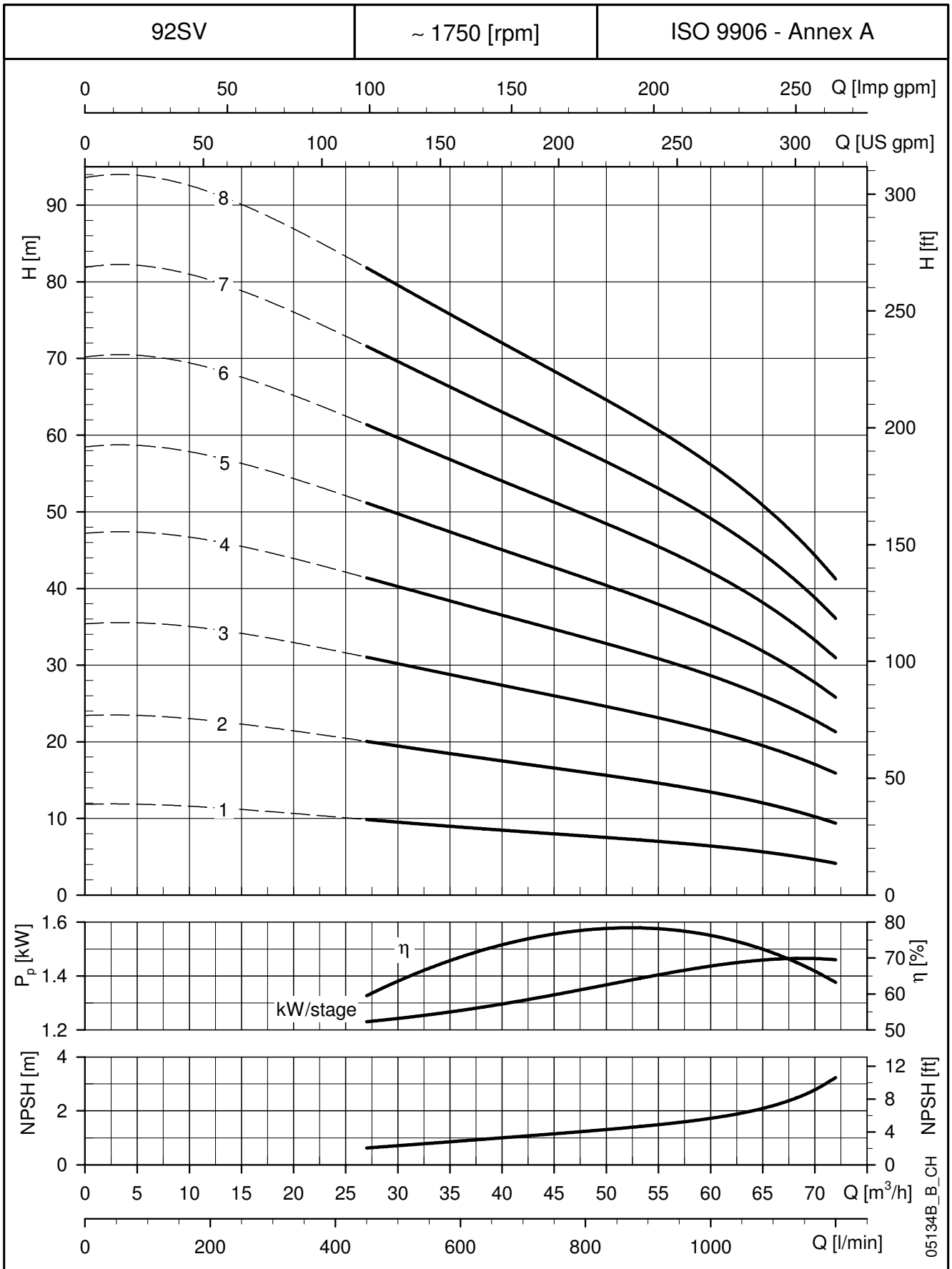

These performances are valid for liquids with density $\rho = 1.0 \text{ Kg/dm}^3$ and kinematic viscosity $\nu = 1 \text{ mm}^2/\text{sec}$.

125SV SERIES DIMENSIONS AND WEIGHTS AT 60 Hz, 4-POLE

125SV G - N
(DN125)

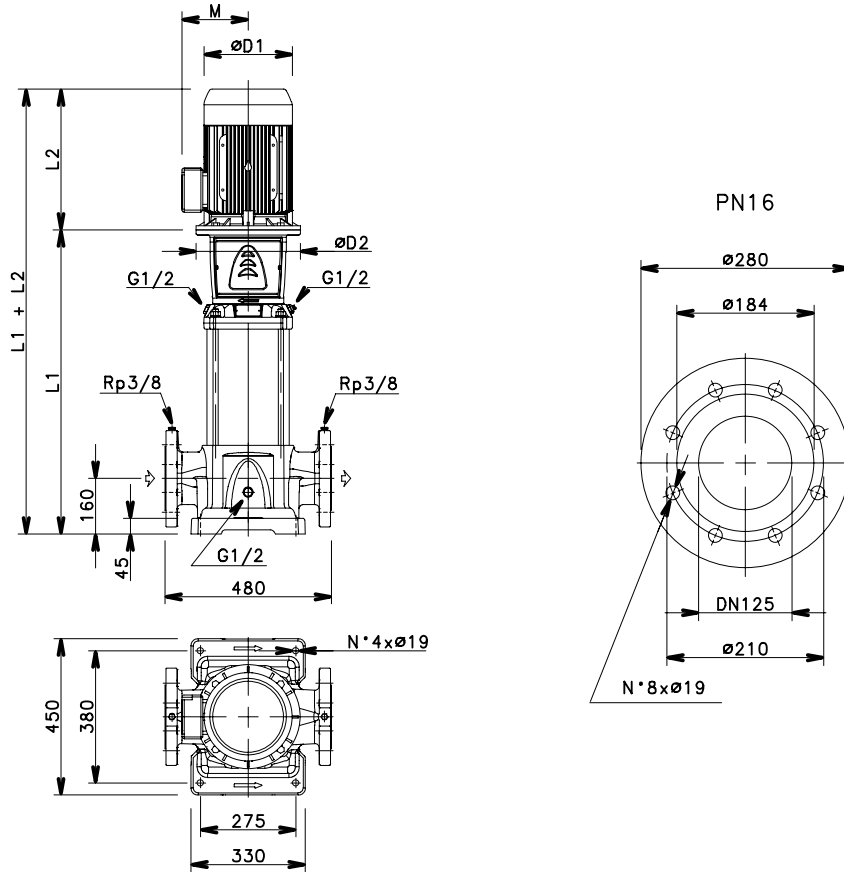

05915_A_DD

PUMP TYPE	MOTOR		DIMENSIONS (mm)						WEIGHT kg	
	kW	SIZE	L1	L2	D1	D2	M	PN	PUMP	ELECTRIC PUMP
125SV1..4..	2,2	100	673	322	214	160	168	16	110	139
125SV2/2A..4..	3	100	823	353	214	160	168	16	121	153
125SV3/3B..4..	4	112	973	398	214	160	168	16	133	184
125SV4/4A..4..	5,5	132	1143	405	256	300	191	16	149	212
125SV5/5A..4..	7,5	132	1293	405	256	300	191	16	160	227
125SV6..4..	11	160	1478	494	313	350	240	16	176	301
125SV7..4..	11	160	1628	494	313	350	240	16	190	315
125SV8..4..	15	160	1778	494	313	350	240	16	203	331

125sv-4p60-en_b_td

4-POLE
(60 Hz)

**125SV SERIES
OPERATING CHARACTERISTICS AT 60 Hz, 4-POLE**

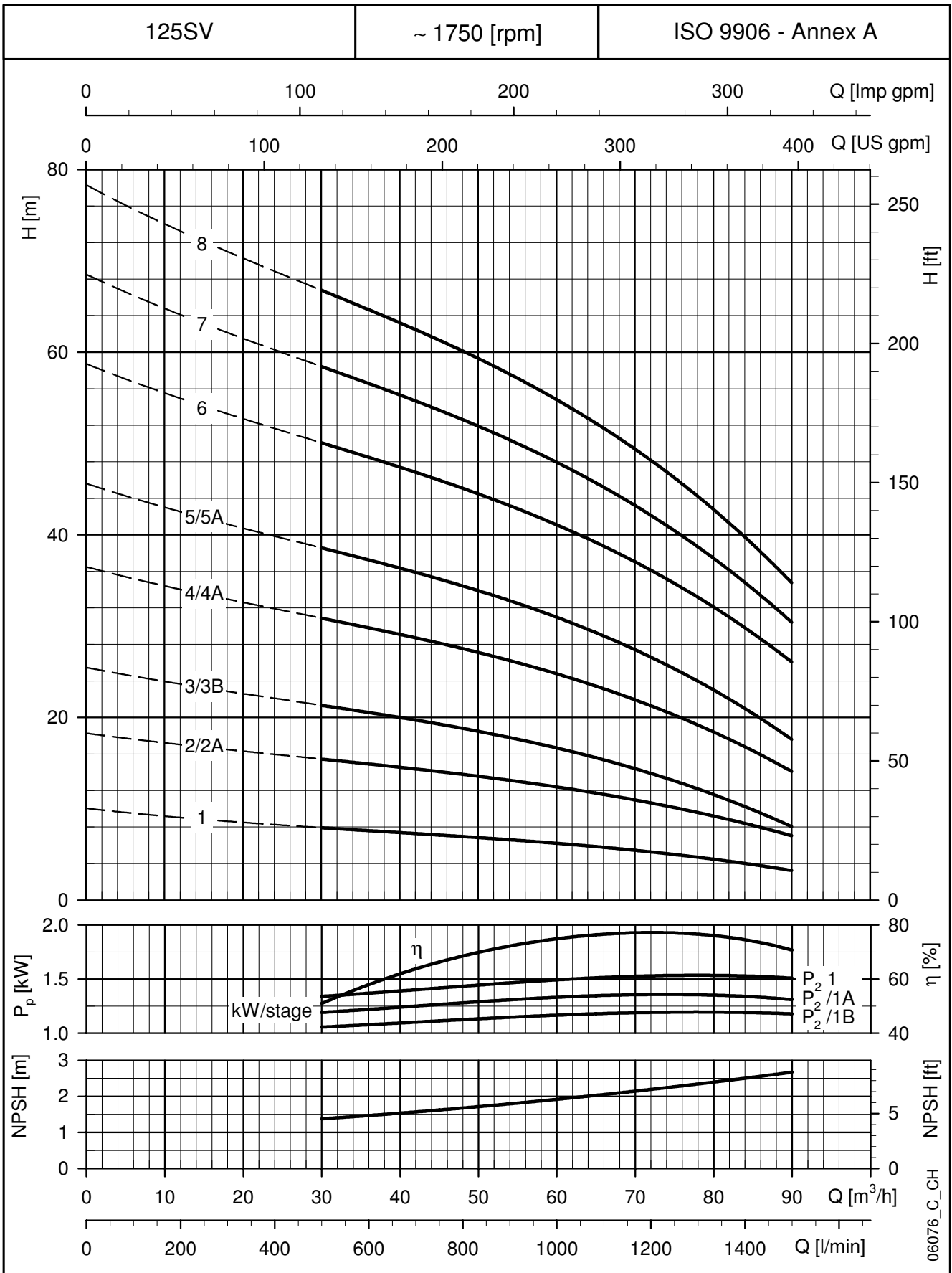

These performances are valid for liquids with density $\rho = 1.0 \text{ Kg/dm}^3$ and kinematic viscosity $\nu = 1 \text{ mm}^2/\text{sec}$.

**4-POLE
(60 Hz)**

REDUCING FOOTPRINT (50/60 Hz)

e-SV™ SERIES - REDUCING FOOTPRINT 50/60 Hz

Background and context

In industry or in the building services market, reducing footprint of pumping equipment is one of the main goals of architects and manufacturing layout designers. They look for compact solutions which help to save space on installation, such as compact water supply installation, compact water booster sets and closed loop circuits. Therefore Lowara has developed e-SV™ Reducing footprint: a pump or booster set which delivers a compact and original solution to the most critical footprint size.

Benefits of e-SV™ Reducing Footprint

Compact design: e-SV™ Reducing the footprint offers up to 50% saving in the plant room dedicated usually for a traditional vertical multistage pump with suction and discharge ports designed inline.

Versatile design: e-SV™ Reducing footprint offers many different configurations with the delivery port above the suction port with 4 adjustable positions. This specific design of the pump allows installing e-SV™ Reducing footprint everywhere, even at a close proximity to a wall.

High level performances: e-SV™ Reducing footprint keeps the same level of performances of the e-SV™ range from size 1SV to 22SV. e-SV™ Reducing footprint is available with round flanges up to PN25.

Code identification

e-SV™ Reducing footprint design is identified with a “R” in the product codification of the whole e-SV™ range.

Example: 3SV13R015T

R = Reducing footprint.

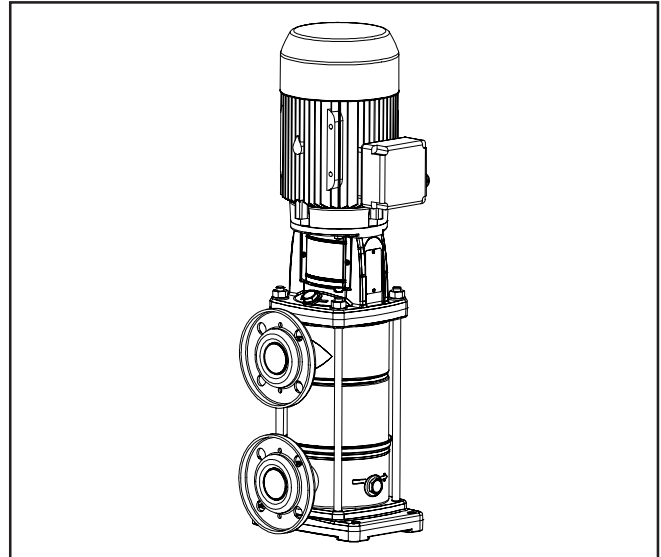

Special features / product benefits

- Specific superposed design of the inlet and outlet allowing savings in up to 50% space.
- **Easy-to-replace balanced standard mechanical seal** (EN12756) on all models from 5,5 kW for easy maintenance **without removing the motor.**
- **Hard material intermediate bush bearing** (Tungsten Carbide) to improve life and ability to withstand heavy duty application on all sizes.
- **Balanced impeller design** (patent pending) to reduce axial thrust for longer standard motor bearing life.
- Wide range of size to cover all requested duty points: from 1SV to 22SV.
- **IE2/IE3 standard motors**, 3-phase, 2-poles from 0,75 kW to 55 kW with blocked bearing **to support maximum thrust without limiting inlet pressure.**
- **i-Alert** device to reduce life cycle costs by increasing Mean time between Failures (MTBF).

Special configurations

e-SV™ Reducing footprint offers the same range of configuration of the standard e-SV™ series.

- Material execution. See Material section.
- Mechanical seal and rubbers options. See Mechanical seal and rubber section.
- Motors options and configuration. See Motor section.
- Hydrovar® drive fitted. See e-SVH – Hydrovar® fitted section.

HORIZONTAL VERSION

e-SV™ SERIES - HORIZONTAL VERSION 50/60 Hz

Background and context

In some applications where room is reduced vertically, it is mandatory to have some pumps systems able to deliver high pressure performances together with a limited occupied vertical space. Therefore Lowara proposes the full range of e-SV™ in the horizontal position: a pump which delivers from a vertical space saving solution together with the high performance of the e-SV™ series.

Benefits of e-SV™ horizontal version

Reduced use of the vertical space: e-SV™ Horizontal version reduces the space usually used vertically by the traditional vertical multistage pumps thanks to a specific range of accessories which allows the installation of the pump in a horizontal position.

Easy installation: any e-SV™ pumps can be installed in a horizontal position. Lowara has developed some specific accessories, which according to the pump model and motor, allow to convert any e-SV™ vertical multistage to a horizontal installation.

Code identification

There is no specific code identification for e-SV™ Horizontal version, since it's a different installation of the standard e-SV™ series.

Special features / product benefits

By being a different installation of the e-SV™ series, the special features and products benefits of e-SV™ Horizontal version are the same as the standard e-SV™ series.

Lowara recommends to use the R version of e-SV™ for horizontal installation in order to drain out the air diluted in the liquid.

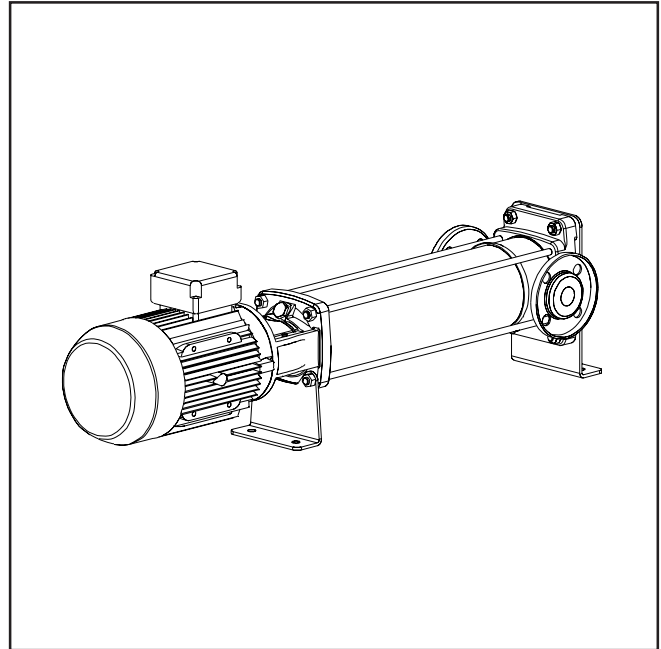

Special configurations

e-SV™ Horizontal version offers the same range of configuration of the standard e-SV™ series.

- Material execution. See Material section.
- Mechanical seal and rubbers options. See Mechanical seal and rubber section.
- Motors options and configuration. See Motor section.
- Hydrovar® drive fitted. See e-SVH – Hydrovar® fitted section.

1-22SV - HORIZONTAL VERSION (For dimensions with Simbol, see related standard catalogue.)

1, 3, 5SV (F-N VERSIONS)

MOTOR		DIMENSIONS (mm)
kW	SIZE	H
0,37÷0,55	71	108
0,75÷1,1	80	118
1,5÷2,2	90	128
3÷4	100-112	138
5,5	132	158

059070R_B_DD 1-5svor-2p50-en_a_td

**10, 15, 22SV (F-N VERSIONS)
(0,75÷11 kW)**

PUMP TYPE	DIMENSIONS (mm)
B	
10SV	280
15SV	300
22SV	300

MOTOR		DIMENSIONS (mm)
kW	SIZE	H
0,75÷1,1	80	142
1,5÷2,2	90	152
3÷4	100-112	162
5,5÷7,5	132	228
11	160	258

059080R_B_DD 10-22svor-b-en_a_td

**15, 22SV (F-N VERSIONS)
(15÷18,5 kW)**

059090R_B_DD

HORIZONTAL VERSION

33-92SV - HORIZONTAL VERSION (For dimensions with Simbol, see related standard catalogue.)

33, 46, 66, 92SV (G-N VERSIONS) (1,1÷11 kW)

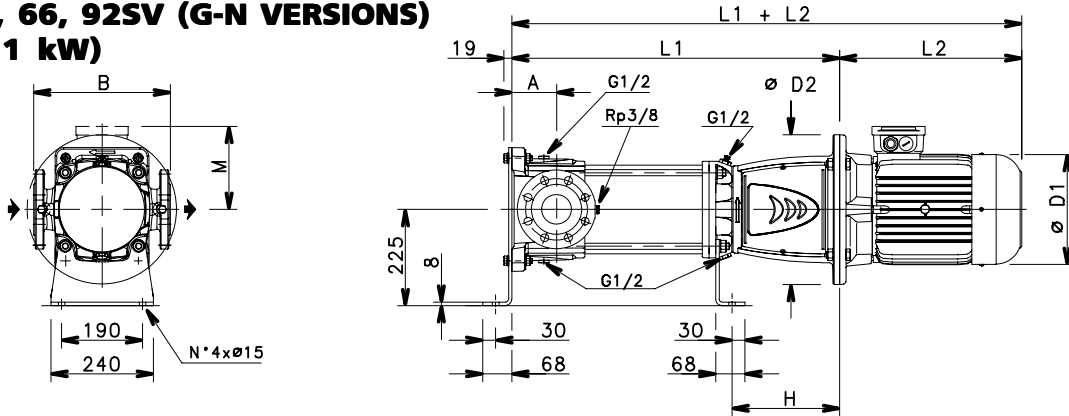

PUMP TYPE	DIMENSIONS (mm)	
	A	B
33SV	105	320
46-66-92SV	140	365

kW	MOTOR SIZE	DIMENSIONS (mm)	
		H	
1,1÷4	90-100-112	196	
5,5÷7,5	132	216	
11	160	251	

05108_C_DD

33-92svo-11kw-2p50-en_a_td

33, 46, 66, 92SV (G-N VERSIONS) (15÷22 kW)

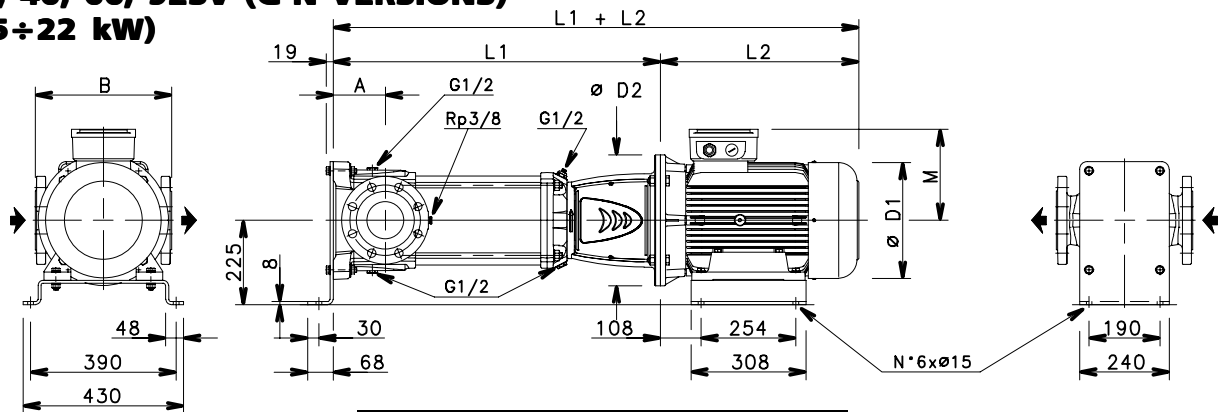

PUMP TYPE	DIMENSIONS (mm)	
	A	B
33SV	105	320
46-66-92SV	140	365

05109_C_DD

33-92svo-22kw-2p50-en_a_td

33, 46, 66, 92SV (G-N VERSIONS) (30÷45 kW)

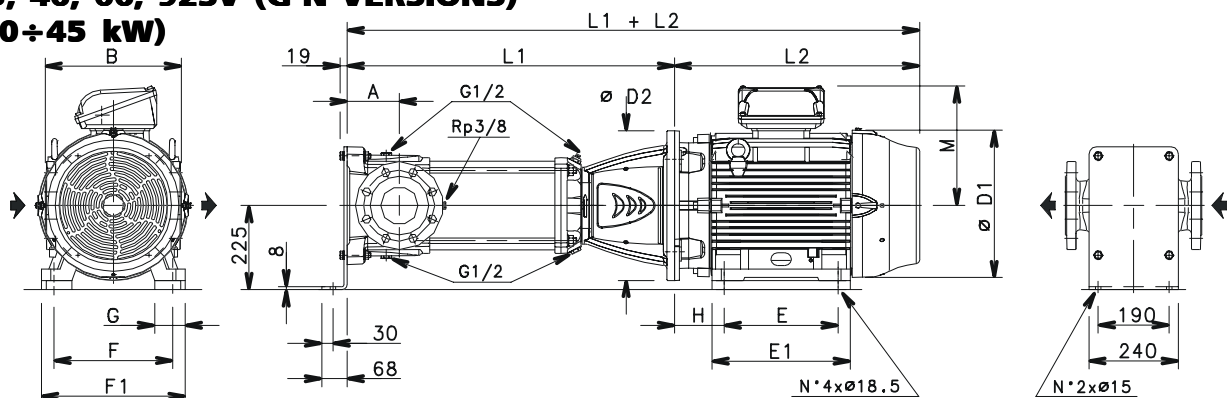

PUMP TYPE	DIMENSIONS (mm)	
	A	B
33SV	105	320
46-66-92SV	140	365

kW	MOTOR SIZE	DIMENSIONS (mm)					
		H	E	E1	F	F1	G
30÷37	200	133	305	370	318	385	82
45	225	149	311	412	356	436	80

05109C_C_DD

33-92svo-45kw-2p50-en_b_td

HORIZONTAL VERSION

125SV - HORIZONTAL VERSION (For dimensions with Simbol, see related standard catalogue.)

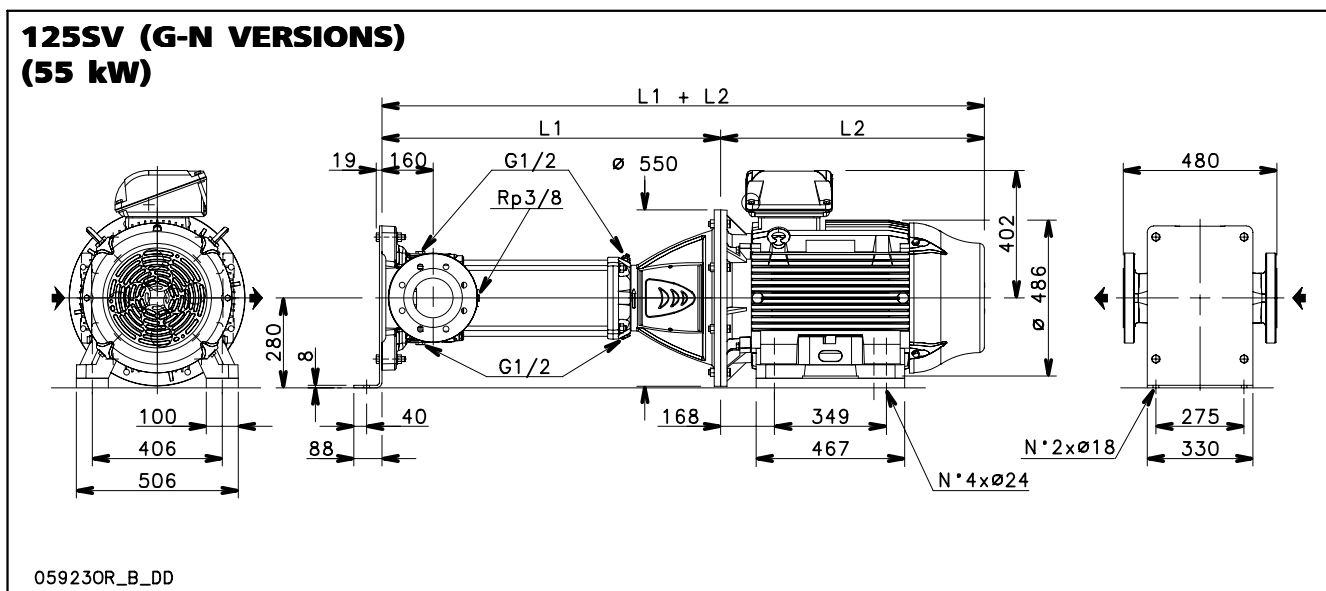
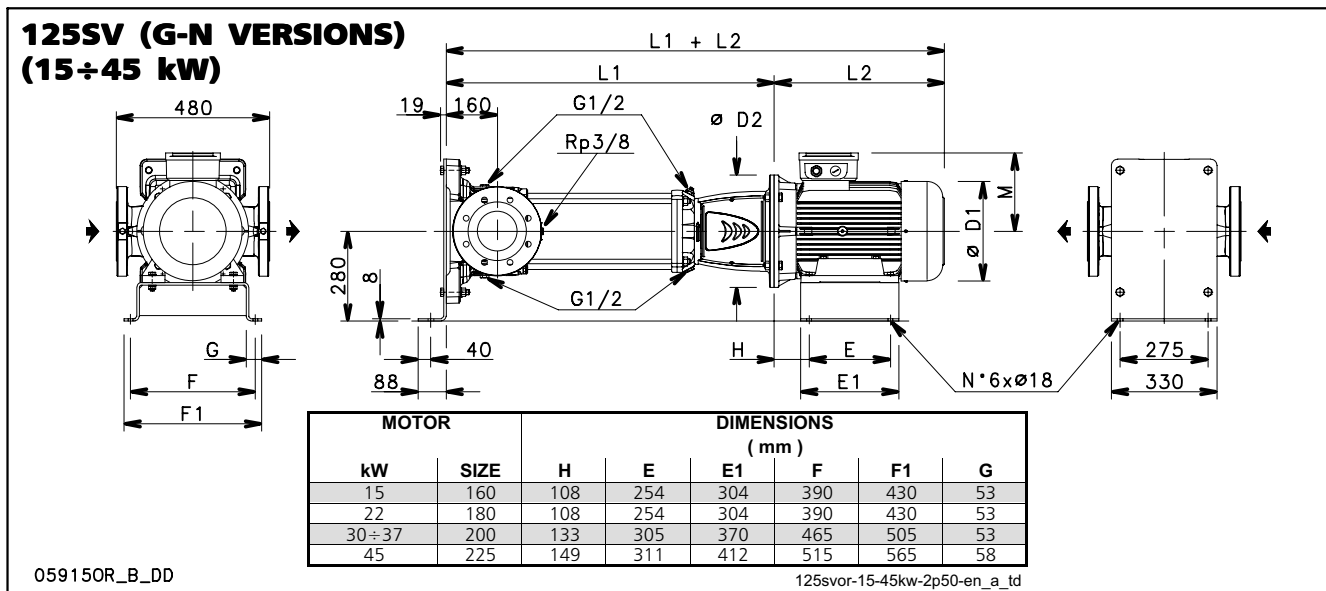
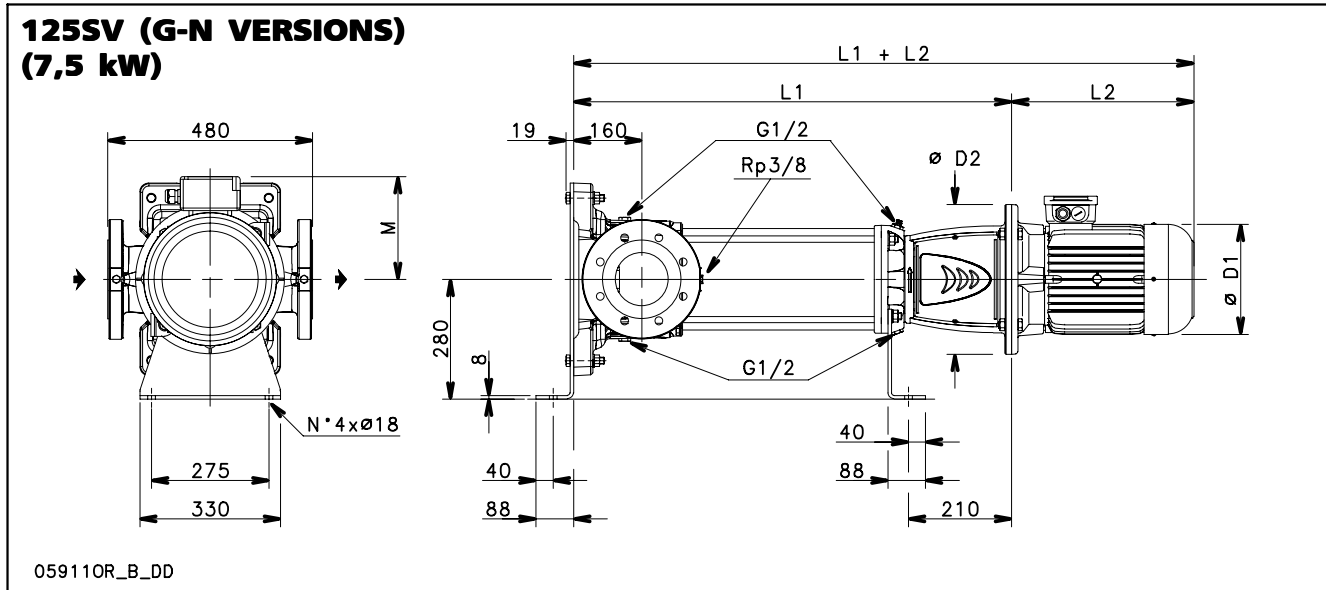

**HORIZONTAL
VERSION**

MOTORS

e-SV™ SERIES MOTORS AT 50 Hz, 2-POLE

Standard supplied SV electric pumps are equipped with Standard motors.

- **Standard supplied IE2/IE3 three-phase surface motors $\geq 0,75$ kW are compliant with Regulation (EC) no. 640/2009 and IEC 60034-30.**
- Short-circuit squirrel-cage motor (TEFC), enclosed construction with external ventilation.
- IP55 protection.
- Class 155 (F) insulation.
- Performance according to EN 60034-1.
- Standard voltage.
- Cable gland with standard passage dimensions according to EN 50262 (metric thread).
- **Single-phase** version: 220-240 V 50 Hz with built-in automatic reset overload protection up to 1,5 kW. For higher powers the protection must be provided by the user.
- **Three-phase** version 220-240/380-415 V 50 Hz for power up to 3 kW. 380-415/660-690 V 50 Hz for power above 3 kW. Overload protection to be provided by the user.
- **PTC** included in motors from 30 to 55 kW.

Standard options surface motors

In addition to a wide range of motors and special voltages, Lowara offers a wide range of standard options to cover all applications linked with the installation of the vertical multistage pumps e-SV™:

High efficiency:

High efficiency IE3 motors
IE2 motors with variable speed drive Hydrovar®
Nema Premium or Nema standard

Non standard ambient installation:

Ambient temperature above 40°C up to 60°C
Insulation class: IP56 – IP65
Space heaters
Tropicalization
Fan cover with canopy

CERTIFICATIONS

UL recognized
Marine certification

Other:

Insulated bearings
Service factor (1.15)

Motor protection:

PTC
PTO
PT100
PTC in the bearings (only on large sizes)
Lowara keeps the right to supply motors from other brand to satisfy some of the requests.

SINGLE-PHASE MOTORS AT 50 Hz, 2-POLE

P _N kW	MOTOR TYPE	IEC SIZE*	Construction Design	INPUT	CAPACITOR		DATA FOR 230 V 50 Hz VOLTAGE						
				CURRENT I _n (A) 220-240 V	μF	V	min ⁻¹	I _s / I _n	η %	cosφ	T _n Nm	T _s /T _n	T _m /T _n
0,37	SM71RB14/104	71R	V18/B14	2,79-2,85	14	450	2745	2,64	65,1	0,96	1,39	0,68	1,63
0,55	SM71B14/105	71		3,76-3,99	16	450	2820	3,72	68,9	0,91	1,86	0,61	2,00
0,75	SM80RB14/107	80R		4,90-4,85	20	450	2765	3,42	70,1	0,96	2,59	0,58	1,75
1,1	SM80B14/111	80		6,88-6,65	30	450	2800	3,89	74,7	0,96	3,75	0,46	1,72
1,5	SM90RB14/115	90R		9,21-8,58	40	450	2810	4,00	76,1	0,98	5,09	0,39	1,74
2,2	PLM90B14/122	90		12,5-11,6	70	450	2825	4,47	82,4	0,97	7,43	0,53	1,87

* R = Reduced size of motor casing as compared to shaft extension and flange.

e-SV™ SERIES THREE-PHASE MOTORS AT 50 Hz, 2-POLE (up to 22 kW)

P _N kW	Efficiency η _N %																		IE	Year of manufacture
	Δ 220 V Y 380 V			Δ 230 V Y 400 V			Δ 240 V Y 415 V			Δ 380 V Y 660 V			Δ 400 V Y 690 V			Δ 415 V				
	4/4	3/4	2/4	4/4	3/4	2/4	4/4	3/4	2/4	4/4	3/4	2/4	4/4	3/4	2/4	4/4	3/4	2/4		
0,37	-	-	-	-	-	-	-	-	-	-	-	-	-	-	-	-	-	-	-	-
0,55	-	-	-	-	-	-	-	-	-	-	-	-	-	-	-	-	-	-	-	-
0,75	82,5	83,1	81,3	82,8	82,7	80,1	82,6	82,0	78,9	82,5	82,0	78,9	82,5	82,0	78,9	82,5	82,0	78,9	-	-
1,1	84,0	84,7	83,4	84,4	84,5	82,5	84,3	84,0	81,4	84,0	84,0	81,4	84,0	84,0	81,4	84,0	84,0	81,4	3	-
1,5	85,6	86,5	85,8	85,9	86,4	84,9	86,0	86,0	84,0	85,6	86,0	84,0	85,6	86,0	84,0	85,6	86,0	84,0	-	-
2,2	83,7	83,7	83,7	83,7	83,7	83,7	83,7	83,7	83,7	83,7	83,7	83,7	83,7	83,7	83,7	83,7	83,7	83,7	-	-
3	85,5	86,8	85,6	86,1	86,8	85,6	86,3	86,8	85,6	85,5	86,8	85,6	85,5	86,8	85,6	85,5	86,8	85,6	-	-
4	86,3	86,3	86,3	86,3	86,3	86,3	86,3	86,3	86,3	86,3	86,3	86,3	86,3	86,3	86,3	86,3	86,3	86,3	-	-
5,5	87,6	87,6	87,6	87,6	87,6	87,6	87,6	87,6	87,6	87,6	87,6	87,6	87,6	87,6	87,6	87,6	87,6	87,6	-	-
7,5	88,6	88,1	88,1	88,6	88,1	88,1	88,6	88,1	88,1	88,6	88,1	88,1	88,6	88,1	88,1	88,6	88,1	88,1	2	-
11	90,3	91,1	90,3	90,3	91,1	90,3	90,3	91,1	90,3	90,3	91,1	90,3	90,8	91,1	90,3	91,0	91,1	91,1	90,3	-
15	90,3	90,3	90,3	90,3	90,3	90,3	90,3	90,3	90,3	90,3	90,3	90,3	90,3	90,3	90,3	90,3	90,3	90,3	-	-
18,5	91,2	91,2	91,2	91,2	91,2	91,2	91,2	91,2	91,2	91,2	91,2	91,2	91,2	91,2	91,2	91,2	91,2	91,2	-	-
22	91,3	91,3	91,3	91,3	91,3	91,3	91,3	91,3	91,3	91,3	91,3	91,3	91,3	91,3	91,3	91,3	91,3	91,3	-	-

P _N kW	Manufacturer		IEC SIZE*	Construction Design	N. of Poles	f _N Hz	Data for 400 V / 50 Hz Voltage				
	Lowara srl Unipersonale Reg. No. 341820260 Montecchio Maggiore Vicenza - Italia						cosφ	I _s / I _N	T _N Nm	Ts/T _N	Tm/Tn
	Model										
0,37	SM71RB14/304		71R	V18/B14	2	50	0,66	4,32	1,38	4,14	3,13
0,55	SM71B14/305		71				0,74	5,97	1,85	3,74	3,56
0,75	SM80B14/307PE		80				0,78	7,38	2,48	3,57	3,75
1,1	SM80B14/311PE		80				0,79	8,31	3,63	3,95	3,95
1,5	SM90RB14/315PE		90R				0,80	8,80	4,96	4,31	4,10
2,2	PLM90B14/322		90				0,80	8,63	7,25	3,74	3,71
3	PLM100RB14/330		100R				0,82	8,39	9,96	3,50	3,32
4	PLM112RB14/340		112R				0,85	9,52	13,1	3,04	4,40
5,5	PLM132RB5/355		132R				0,87	10,3	18,1	4,43	5,80
7,5	PLM132B5/375		132				0,87	9,21	24,5	3,26	4,55
11	PLM160RB5/3110		160R	0,87	9,72	36,0	3,46	4,56			
15	PLM160B5/3150		160	0,91	8,45	48,6	2,26	3,81			
18,5	PLM160B5/3185		160	0,88	9,75	59,8	2,82	4,53			
22	PLM180RB5/3220		180R	0,89	9,50	71,1	2,74	4,26			

P _N kW	Voltage U _N V											n _N min ⁻¹	Observe the regulations and codes locally in force regarding sorted waste disposal.	Operating conditions **		
	Δ			Y			Δ			Y				Altitude Above Sea Level (m)	T. amb min/max °C	ATEX
	220 V	230 V	240 V	380 V	400 V	415 V	380 V	400 V	415 V	660 V	690 V					
0,37	2,20	2,34	2,51	1,27	1,35	1,45	-	-	-	-	-	2740 ÷ 2790	≤ 1000	-15 / 40	No	
0,55	2,56	2,56	2,62	1,48	1,48	1,51	-	-	-	-	-	2825 ÷ 2850				
0,75	2,96	2,94	2,96	1,71	1,70	1,71	1,70	1,69	1,70	0,98	0,98	2875 ÷ 2895				
1,1	4,19	4,14	4,16	2,42	2,39	2,40	2,41	2,38	2,38	1,39	1,37	2870 ÷ 2900				
1,5	5,56	5,49	5,51	3,21	3,17	3,18	3,21	3,18	3,19	1,85	1,84	2870 ÷ 2895				
2,2	8,05	8,04	8,09	4,65	4,64	4,67	4,62	4,61	4,63	2,67	2,66	2885 ÷ 2900				
3	10,8	10,6	10,6	6,23	6,14	6,12	6,18	6,10	6,06	3,57	3,52	2850 ÷ 2885				
4	13,6	13,5	13,5	7,88	7,77	7,79	7,80	7,63	7,65	4,51	4,41	2895 ÷ 2920				
5,5	18,3	18,0	17,9	10,6	10,4	10,3	10,6	10,4	10,5	6,14	6,02	2885 ÷ 2905				
7,5	25,4	24,8	24,4	14,7	14,3	14,1	14,5	14,0	13,9	8,35	8,11	2920 ÷ 2935				
11	36,0	35,1	34,7	20,8	20,3	20,0	20,8	20,3	20,1	12,0	11,7	2910 ÷ 2925				
15	47,2	45,3	44,0	27,2	26,2	25,4	27,2	26,0	25,3	15,7	15,0	2940 ÷ 2950				
18,5	58,3	56,9	55,9	33,7	32,9	32,3	34,1	33,2	32,8	19,7	19,1	2945 ÷ 2955				
22	68,3	66,2	64,3	39,4	38,2	37,1	40,0	38,6	37,8	23,1	22,3	2945 ÷ 2955				

* R = Reduced size of motor casing as compared to shaft extension and flange.

sv-ie2-mott22-2p50-en_c_tte

** Operating conditions to be referred to motor only. About electric pump, refer to limits in user's manual.

e-SV™ SERIES THREE-PHASE MOTORS AT 50 Hz, 2-POLE (from 30 to 55 kW)

P _N kW	Efficiency η_N %									IE	Year of manufacture
	Δ 380 V Y 660 V			Δ 400 V Y 690 V			Δ 415 V				
	4/4	3/4	2/4	4/4	3/4	2/4	4/4	3/4	2/4		
30	92,6	92,9	92,7	92,5	93,0	92,9	93,0	93,0	92,3	2	By June 2011
37	93,0	93,3	93,2	93,0	93,4	93,3	93,5	93,4	92,8		
45	93,2	93,5	93,4	93,3	93,6	93,6	93,8	93,6	93,1		
55	93,6	93,8	93,8	93,6	93,9	93,9	94,0	93,8	93,3		

P _N kW	Manufacturer		IEC SIZE	Construction Design	N. of Poles	f _N Hz	Data for 400 V / 50 Hz Voltage				
	WEG Equipamentos Eletricos S.A. Reg. No. 07.175.725/0010-50 Jaragua do Sul - SC (Brazil)						cos ϕ	I _s / I _N	T _N Nm	T _s /T _N	T _m /T _N
	Model										
30	W22 200L2-B5 30kW		200	V1/B5	2	50	0,87	6,50	97,00	2,40	2,70
37	W22 200L2-B5 37kW		200				0,87	6,80	120,0	2,40	2,60
45	W22 225S/M2-B5 45kW		225				0,89	7,00	145,0	2,20	2,80
55	W22 250S/M2-B5 55kW		250				0,89	7,00	178,0	2,20	2,80

P _N kW	Voltage U _N V					n _N min ⁻¹	See note.	Operating conditions **		
	Δ			Y				Altitude Above Sea Level (m)	T. amb min/max °C	ATEX
	380 V	400 V	415 V	660 V	690 V					
	I _N (A)									
30	55,90	53,60	52,20	32,18	31,07	2950 ÷ 2960	≤ 1000	-15 / 40	No	
37	68,70	65,80	64,00	39,55	38,14	2945 ÷ 2955				
45	81,50	78,00	75,80	46,92	45,22	2955 ÷ 2960				
55	99,20	95,00	92,50	57,12	55,07	2955 ÷ 2960				

** Operating conditions to be referred to motor only. About electric pump, refer to limits in user's manual.

sv-ie2-mott55-2p50-en_a_te

Note: Observe the regulations and codes locally in force regarding sorted waste disposal.

MOTOR NOISE AT 50 Hz, 2-POLE

POWER kW	MOTOR TYPE IEC SIZE*	NOISE LpA dB
0,37	71R	<70
0,55	71	<70
0,75	80-80R	<70
1,1	80	<70
1,5	90-90R	<70
2,2	90	<70
3	100R	<70
4	112R	<70
5,5	132R	<70
7,5	132	71
11	160R	73
15	160	71
18,5	160	73
22	180R	70
30	200	72
37	200	72
45	225	75
55	250	75

*R = Reduced motor casing size with respect to shaft extension and related flange.

1-125sv_mott_2p50-en_b_tr

The table show the mean sound pressure (Lp) measured as per Curve A (Standard ISO 1680).

Noise values were measured with the 50 Hz motor running idle with a tolerance of 3 dB (A).

e-SV™ SERIES THREE-PHASE MOTORS AT 50 Hz, 4-POLE

P _N kW	Efficiency η _N %																		IE	Year of manufacture				
	Δ 220 V Y 380 V			Δ 230 V Y 400 V			Δ 240 V Y 415 V			Δ 380 V Y 660 V			Δ 400 V Y 690 V			Δ 415 V								
	4/4	3/4	2/4	4/4	3/4	2/4	4/4	3/4	2/4	4/4	3/4	2/4	4/4	3/4	2/4	4/4	3/4	2/4						
0,25	-	-	-	-	-	-	-	-	-	-	-	-	-	-	-	-	-	-	-	-	-	-	-	-
0,37	-	-	-	-	-	-	-	-	-	-	-	-	-	-	-	-	-	-	-	-	-	-	-	-
0,55	-	-	-	-	-	-	-	-	-	-	-	-	-	-	-	-	-	-	-	-	-	-	-	-
0,75	80,4	81,3	79,8	81,1	81,4	79,1	81,4	81,2	78,4	80,4	81,2	78,4	80,4	81,2	78,4	80,4	81,2	78,4	80,4	81,2	78,4	80,4	81,2	78,4
1,1	81,4	81,4	81,1	81,4	81,4	81,1	81,4	81,4	81,1	81,4	81,4	81,1	81,4	81,4	81,1	81,4	81,4	81,1	81,4	81,4	81,1	81,4	81,4	81,1
1,5	83,1	83,1	82,0	83,1	83,1	82,0	83,1	83,1	82,0	83,1	83,1	82,0	83,1	83,1	82,0	83,1	83,1	82,0	83,1	83,1	82,0	83,1	83,1	82,0
2,2	84,7	84,7	84,7	84,7	84,7	84,7	84,7	84,7	84,7	84,7	84,7	84,7	84,7	84,7	84,7	84,7	84,7	84,7	84,7	84,7	84,7	84,7	84,7	84,7
3	85,5	85,5	84,1	85,5	85,5	84,1	85,5	85,5	84,1	85,5	85,5	84,1	85,5	85,5	84,1	85,5	85,5	84,1	85,5	85,5	84,1	85,5	85,5	84,1
4	86,6	86,6	86,6	86,6	86,6	86,6	86,6	86,6	86,6	86,6	86,6	86,6	86,6	86,6	86,6	86,6	86,6	86,6	86,6	86,6	86,6	86,6	86,6	86,6
5,5	88,0	88,0	88,0	88,0	88,0	88,0	88,0	88,0	88,0	88,0	88,0	88,0	88,0	88,0	88,0	88,0	88,0	88,0	88,0	88,0	88,0	88,0	88,0	88,0
7,5	88,7	88,7	88,7	88,7	88,7	88,7	88,7	88,7	88,7	88,7	88,7	88,7	88,7	88,7	88,7	88,7	88,7	88,7	88,7	88,7	88,7	88,7	88,7	88,7

P _N kW	Manufacturer		IEC SIZE*	Construction Design	N. of Poles	f _N Hz	Data for 400 V / 50 Hz Voltage				
	Lowara srl Unipersonale Reg. No. 341820260 Montecchio Maggiore Vicenza - Italia						cosφ	I _s / I _N	T _N Nm	T _s /T _N	T _m /T _N
	Model										
0,25	SM471B14/302		71	V18/B14	4	50	0,59	3,58	1,71	3,16	2,63
0,37	SM471B14/304		71				0,60	3,39	2,57	3,40	2,47
0,55	SM480B14/305		80				0,67	3,95	3,77	2,45	2,38
0,75	LLM480B14/307		80				0,75	5,78	5,03	2,77	3,31
1,1	PLM490B14/311		90				0,72	6,34	7,27	2,80	3,43
1,5	PLM490B14/315		90				0,67	6,79	9,88	3,33	3,67
2,2	PLM4100B14/322		100				0,77	7,50	14,4	2,71	3,97
3	PLM4100B14/330		100				0,73	7,84	19,6	2,96	4,09
4	PLM4112B14/340		112				0,78	7,91	26,3	2,86	3,94
5,5	PLM4132B5/355		132				0,78	7,89	35,9	2,79	3,47
7,5	PLM4132B5/375		132	0,78	7,71	49,1	2,75	3,63			

P _N kW	Voltage U _N V										n _N min ⁻¹	Observe the regulations and codes locally in force regarding sorted waste disposal.	Operating conditions **			
	Δ			Y			Δ			Y			Altitude Above Sea Level (m)	T. amb min/max °C	ATEX	
	220 V	230 V	240 V	380 V	400 V	415 V	380 V	400 V	415 V	660 V						690 V
0,25	1,68	1,71	1,77	0,97	0,99	1,02	-	-	-	-	-	1375 ÷ 1400	≤ 1000	-15 / 40	No	
0,37	2,46	2,53	2,62	1,42	1,46	1,51	-	-	-	-	-	1355 ÷ 1380				
0,55	2,98	3,03	3,10	1,72	1,75	1,79	-	-	-	-	-	1380 ÷ 1400				
0,75	3,08	3,03	3,01	1,78	1,75	1,74	1,78	1,75	1,74	1,03	1,01	1410 ÷ 1430				
1,1	4,64	4,61	4,61	2,68	2,66	2,66	2,66	2,64	2,64	1,54	1,53	1435 ÷ 1445				
1,5	6,50	6,51	6,62	3,75	3,76	3,82	3,74	3,75	3,80	2,16	2,16	1440 ÷ 1450				
2,2	8,49	8,31	8,24	4,90	4,80	4,76	4,87	4,78	4,72	2,81	2,76	1445 ÷ 1455				
3	12,0	11,9	12,0	6,91	6,89	6,94	6,88	6,86	6,90	3,97	3,96	1455 ÷ 1465				
4	15,5	15,3	15,2	8,93	8,82	8,78	8,80	8,64	8,60	5,08	4,99	1445 ÷ 1455				
5,5	20,4	19,9	19,6	11,8	11,5	11,3	11,9	11,5	11,5	6,85	6,66	1455 ÷ 1465				
7,5	27,4	26,8	26,4	15,8	15,5	15,2	15,9	15,6	15,4	9,20	8,98	1450 ÷ 1460				

** Operating conditions to be referred to motor only. About electric pump, refer to limits in user's manual.

sv-ie2-mott15-4p50-en_b_te

e-SV™ SERIES

MOTOR NOISE AT 50 Hz, 4-POLE

The table show the mean sound pressure (Lp) measured as per Curve A (Standard ISO 1680).
 Noise values were measured with the 50 Hz motor running idle with a tolerance of 3 dB (A).

MOTORS AT 50 Hz, 4-POLE

POWER	MOTOR TYPE	NOISE
kW	IEC SIZE	LpA dB
0,25	71	<70
0,37	71	<70
0,55	80	<70
0,75	80	<70
1,1	90	<70
1,5	90	<70
2,2	100	<70
3	100	<70
4	112	<70
5,5	132	<70
7,5	132	<70

1-125sv_mott_4p50-en_a_tr

e-SV™ SERIES MOTORS AT 60 Hz, 2-POLE

Standard supplied SV electric pumps are equipped with Standard motors.

- **Standard supplied IE2/IE3 three-phase surface motors $\geq 0,75$ kW are compliant with Regulation (EC) no. 640/2009 and IEC 60034-30.**
- Short-circuit squirrel-cage motor (TEFC), enclosed construction with external ventilation.
- IP55 protection.
- Class 155 (F) insulation.
- Performance according to EN 60034-1.
- Standard voltage.
- Cable gland with standard passage dimensions according to EN 50262 (metric thread).
- **Single-phase** version: 220-230 V 60 Hz with built-in automatic reset overload protection up to 1,5 kW. For higher powers the protection must be provided by the user.
- **Three-phase** version 2 pole: 220 V Δ , 380 V Y , 60 Hz up to 55 kW. Overload protection to be provided by the user.

Standard options surface motors

In addition to a wide range of motors and special voltages, Lowara offers a wide range of standard options to cover all applications linked with the installation of the vertical multistage pumps e-SV™:

High efficiency:

High efficiency IE3 motors
IE2 motors with variable speed drive Hydrovar®

Non standard ambient installation:

Ambient temperature above 40°C up to 60°C
Insulation class: IP56 – IP65
Space heaters
Tropicalization
Fan cover with canopy

Motor protection:

PTC
PTO
PT100
PTC in the bearings (only on large sizes)

CERTIFICATIONS

UL recognized: Nema Premium and Nema standard
Marine certification

Other:

Insulated bearings
Service factor (1.15)

Lowara keeps the right to supply motors from other brand to satisfy some of the requests.

SINGLE-PHASE MOTORS AT 60 Hz, 2-POLE

P _N kW	MOTOR TYPE	IEC SIZE*	Construction Design	INPUT	CAPACITOR		DATA FOR 220 V 60 Hz VOLTAGE						
				CURRENT I _n (A) 220-230 V	μ F	V	min ⁻¹	I _s / I _n	η %	cos ϕ	T _n Nm	T _s /T _n	T _m /T _n
0,4	SM71RB14/1046	71R	V18/B14	2,86-2,94	14	450	3385	3,80	67,5	0,94	1,13	0,73	2,04
0,55	SM71B14/1056	71		3,68-3,62	16	450	3400	4,28	70,2	0,97	1,54	0,66	2,11
0,75	SM80RB14/1076	80R		4,98-4,88	20	450	3380	3,90	69,8	0,98	2,12	0,64	1,91
1,1	SM80B14/1116	80		6,94-6,89	30	450	3435	4,54	74,2	0,97	3,06	0,62	2,03
1,5	SM90RB14/1156	90R		9,28-9,35	40	450	3455	4,91	76,3	0,96	4,14	0,49	2,19
2,2	PLM90B14/1226	90		12,3-11,7	60	450	3455	4,99	83,4	0,98	6,08	0,54	2,06

* R =Reduced size of motor casing as compared to shaft extension and flange.

1-22sv-motm-2p60_en_d_te

e-SV™ SERIES THREE-PHASE MOTORS AT 60 Hz, 2-POLE (up to 22 kW)

P _N kW	Efficiency η _N %												Year of construction	
	Δ 220 V Y 380 V			Δ 230 V Y 400 V			Δ 380 V Y 660 V			Δ 400 V Y 690 V				IE
	4/4	3/4	2/4	4/4	3/4	2/4	4/4	3/4	2/4	4/4	3/4	2/4		
0,4	-	-	-	-	-	-	-	-	-	-	-	-	-	-
0,55	-	-	-	-	-	-	-	-	-	-	-	-	-	-
0,75	83,4	82,4	79,0	83,4	82,4	79,0	83,4	82,4	79,0	83,4	82,4	79,0	3	By June 2011
1,1	85,6	85,0	82,1	85,6	85,0	82,1	85,6	85,0	82,1	85,6	85,0	82,1		
1,5	87,2	87,0	84,6	87,2	87,0	84,6	87,2	87,0	84,6	87,2	87,0	84,6		
2,2	85,5	85,5	84,5	85,5	85,5	84,5	85,5	85,5	84,5	85,5	85,5	84,5	2	
3	87,8	88,0	86,0	87,8	88,0	86,0	87,8	88,0	86,0	87,8	88,0	86,0		
4	87,5	87,5	86,8	87,5	87,5	86,8	87,5	87,5	86,8	87,5	87,5	86,8		
5,5	88,5	88,5	88,5	88,5	88,5	88,5	88,5	88,5	88,5	88,5	88,5	88,5		
7,5	89,5	89,5	88,5	89,5	89,5	88,5	89,5	89,5	88,5	89,5	89,5	88,5		
11	90,2	90,2	89,7	90,2	90,2	89,7	90,2	90,2	89,7	90,2	90,2	89,7		
15	90,2	90,2	90,2	90,2	90,2	90,2	90,2	90,2	90,2	90,2	90,2	90,2		
18,5	91,0	91,0	91,0	91,0	91,0	91,0	91,0	91,0	91,0	91,0	91,0	91,0		
22	91,0	91,0	91,0	91,0	91,0	91,0	91,0	91,0	91,0	91,0	91,0	91,0		

P _N kW	Manufacturer		IEC SIZE*	Construction Design	N. of Poles	f _N Hz	Data for 380 V / 60 Hz				
	Lowara srl Unipersonale Reg. No. 341820260 Montecchio Maggiore Vicenza - Italia						cosφ	I _s / I _N	TN Nm	Ts/T _N	Tm/T _N
	Model										
0,4	SM071RB14/304		71R	V18/B14	2	60	0,81	4,76	1,16	3,48	2,15
0,55	SM071B14/305		71				0,84	5,83	1,55	3,09	2,77
0,75	SM080B14/307PE		80				0,79	8,25	2,05	3,80	4,02
1,1	SM080B14/311PE		80				0,80	9,11	3,01	4,15	4,29
1,5	SM090RB14/315PE		90R				0,82	9,79	4,10	4,36	4,37
2,2	PLM090B14/322		90				0,83	9,59	6,00	3,80	4,02
3	PLM100RB14/330		100R				0,84	9,12	8,22	3,52	3,65
4	PLM112RB14/340		112R				0,87	10,0	10,87	2,82	4,58
5,5	PLM132RB5/355		132R	V1/B5	2	60	0,89	11,4	14,97	4,28	5,80
7,5	PLM132B5/375		132				0,88	9,83	20,29	3,21	4,68
11	PLM160RB5/3110		160R				0,88	10,2	29,81	3,43	4,51
15	PLM160B5/3150		160				0,91	8,60	40,41	2,24	3,84
18,5	PLM160B5/3185		160				0,89	9,97	49,72	2,78	4,59
22	PLM180RB5/3220		180R				0,91	9,64	59,15	2,76	4,25

P _N kW	Voltage U _N V								η _N min ⁻¹	Operating conditions **			
	Δ		Y		Δ		Y			Altitude above sea Level (m)	T. amb min/max °C	ATEX	
	220 V	230 V	380 V	400 V	380 V	400 V	660 V	690 V					
0,4	1,96	1,89	1,13	1,09	-	-	-	-	3280 ÷ 3335	Observe the regulations and codes locally in force regarding sorted waste disposal.	1000	-15 / 40	No
0,55	2,37	2,30	1,37	1,33	-	-	-	-	3380 ÷ 3415				
0,75	3,03	3,01	1,75	1,74	1,75	1,74	1,01	1,00	3490 ÷ 3500				
1,1	4,24	4,24	2,45	2,45	2,44	2,43	1,41	1,40	3490 ÷ 3505				
1,5	5,58	5,53	3,22	3,19	3,23	3,22	1,86	1,86	3485 ÷ 3505				
2,2	8,14	8,12	4,70	4,69	4,69	4,68	2,71	2,70	3495 ÷ 3505				
3	10,7	10,5	6,19	6,06	6,20	6,11	3,58	3,53	3480 ÷ 3495				
4	13,5	13,5	7,82	7,77	7,84	7,77	4,52	4,49	3510 ÷ 3520				
5,5	18,2	18,1	10,5	10,4	10,5	10,4	6,07	6,02	3505 ÷ 3515				
7,5	25,2	24,7	14,6	14,3	14,6	14,1	8,40	8,16	3525 ÷ 3535				
11	36,1	35,2	20,8	20,3	21,1	20,7	12,2	12,0	3520 ÷ 3540				
15	47,1	45,6	27,2	26,4	27,3	26,3	15,8	15,2	3545 ÷ 3550				
18,5	59,2	58,2	34,2	33,6	34,3	33,6	19,8	19,4	3550 ÷ 3555				
22	69,1	67,4	39,9	38,9	39,8	38,2	23,0	22,0	3545 ÷ 3555				

* R = Reduced size of motor casing as compared to shaft extension and flange.

sv-ie2-mott22-2p60_c_te

** Operating conditions to be referred to motor only. About electric pump, refer to limits in user's manual.

MOTORS 60HZ

e-SV™ SERIES THREE-PHASE MOTORS AT 60 Hz, 2-POLE (from 30 to 55 kW)

P _N kW	Efficiency η_N %			IE	Year of construction
	Δ 220 V	Y 380 V			
	4/4	3/4	2/4		
30	92,4	92,4	91,5	2	By June 2011
37	92,4	92,4	92,0		
45	93,5	93,0	91,8		
55	93,5	93,5	92,8		

P _N kW	Manufacturer	IEC SIZE	Construction Design	N. of Poles	f _N Hz	Data for 380 V / 60 Hz				
	Model					cos ϕ	I _s / I _N	T _N Nm	T _s /T _N	T _m /T _N
	WEG Equipamentos Eletricos S.A. Reg. No. 07.175.725/0010-50 Jaragua do Sul - SC (Brazil)									
30	W22 200L2-B5 30kW	200	V1/B5	2	60	0,86	6,40	80,65	2,10	2,40
37	W22 200L2-B5 37kW	200				0,86	7,20	98,98	2,40	2,60
45	W22 225S/M2-B5 45kW	225				0,89	7,80	120,5	2,20	2,90
55	W22 250S/M2-B5 55kW	250				0,89	7,70	147,0	2,20	2,80

P _N kW	Voltage U _N V		η_N min ⁻¹	See note:	Operating conditions **		
	Δ 220 V	Y 380 V			Altitude above sea Level (m)	T. amb min/max °C	ATEX
	I _N (A)				1000 VI	-15 / 40	No
30	99,0	57,3	3550				
37	122,0	70,7	3555				
45	142,0	82,2	3560				
55	173,0	100,0	3560				

** Operating conditions to be referred to motor only. About electric pump, refer to limits in user's manual.

sv-ie2-mott55-2p60_a_te

Note: Observe the regulations and codes locally in force regarding sorted waste disposal.

MOTOR NOISE AT 60 Hz, 2-POLE

POWER kW	MOTOR TYPE IEC SIZE*	NOISE LpA dB
0,37	71R	<70
0,55	71	<70
0,75	80-80R	<70
1,1	80	<70
1,5	90-90R	<70
2,2	90	<70
3	100R	<70
4	112R	<70
5,5	132R	<70
7,5	132	76
11	160R	77
15	160	74
18,5	160	75
22	180R	73
30	200	74
37	200	74
45	225	79
55	250	79

*R = Reduced motor casing size with respect to shaft extension and related flange.

1-125sv_mott_2p60_c_tr

The table show the mean sound pressure (Lp) measured as per Curve A (Standard ISO 1680).

Noise values were measured with the 60 Hz motor running idle with a tolerance of 3 dB (A).

60Hz

MOTORS

e-SV™ SERIES THREE-PHASE MOTORS AT 60 Hz, 4-POLE

P _N kW	Efficiency η _N %												Year of construction	
	Δ 220 V Y 380 V			Δ 230 V Y 400 V			Δ 380 V Y 660 V			Δ 400 V Y 690 V				IE
	4/4	3/4	2/4	4/4	3/4	2/4	4/4	3/4	2/4	4/4	3/4	2/4		
0,25	-	-	-	-	-	-	-	-	-	-	-	-	-	-
0,37	-	-	-	-	-	-	-	-	-	-	-	-	-	-
0,55	-	-	-	-	-	-	-	-	-	-	-	-	-	-
0,75	83,2	82,3	78,4	83,2	82,3	78,4	83,2	82,3	78,4	83,2	82,3	78,4	2	By June 2011
1,1	84,0	84,0	81,0	84,0	84,0	81,0	84,0	84,0	81,0	84,0	84,0	81,0		
1,5	84,5	84,5	82,5	84,5	84,5	82,5	84,5	84,5	82,5	84,5	84,5	82,5		
2,2	87,5	87,5	85,7	87,5	87,5	85,7	87,5	87,5	85,7	87,5	87,5	85,7		
3	87,5	87,5	84,7	87,5	87,5	84,7	87,5	87,5	84,7	87,5	87,5	84,7		
4	87,9	87,9	87,6	87,9	87,9	87,6	87,9	87,9	87,6	87,9	87,9	87,6		
5,5	89,5	89,5	88,7	89,5	89,5	88,7	89,5	89,5	88,7	89,5	89,5	88,7		
7,5	89,5	89,5	89,2	89,5	89,5	89,2	89,5	89,5	89,2	89,5	89,5	89,2		
11	91,0	91,0	91,0	91,0	91,0	91,0	91,0	91,0	91,0	91,0	91,0	91,0		
15	91,0	91,0	90,4	91,0	91,0	90,4	91,0	91,0	90,4	91,0	91,0	90,4		

P _N kW	Manufacturer		IEC SIZE	Construction Design	N. of Poles	f _N Hz	Data for 380 V / 60 Hz				
	Lowara srl Unipersonale Reg. No. 341820260 Montecchio Maggiore Vicenza - Italia						cosφ	I _s / I _N	TN Nm	T _s /T _N	T _m /T _N
	Model										
0,25	SM471B14/302		71	V18/B14	4	60	0,68	3,45	1,45	2,37	2,15
0,37	SM471B14/304		71				0,68	3,52	2,17	2,65	2,05
0,55	SM480B14/305		80				0,77	3,55	3,18	1,80	1,90
0,75	LLM480B14/307		80				0,75	6,26	4,14	2,82	3,53
1,1	PLM490B14/311		90				0,71	6,70	6,01	2,57	3,60
1,5	PLM490B14/315		90				0,68	7,19	8,18	3,04	3,74
2,2	PLM4100B14/322		100				0,76	8,01	12,0	2,69	4,33
3	PLM4100B14/330		100				0,72	8,19	16,3	2,98	4,28
4	PLM4112B5/340		112				0,78	8,48	21,8	3,01	4,22
5,5	PLM4132B5/355		132				0,78	7,85	29,8	2,61	3,48
7,5	PLM4132B5/375		132	0,79	7,84	40,8	2,43	3,59			
11	PLM4160B5/3110		160	0,85	7,25	59,4	2,27	3,07			
15	PLM4160B5/3150		160	0,82	8,17	80,7	2,65	3,64			

P _N kW	Voltage U _N V								η _N min ⁻¹	Operating conditions **			
	Δ		Y		Δ		Y			Altitude abov. sea Level (m)	T. amb min/max °C	ATEX	
	220 V	230 V	380 V	400 V	380 V	400 V	660 V	690 V					
	I _N (A)												
0,25	1,51	0,00	0,87	0	0	0	0	0	1650	Observe the regulations and codes locally in force regarding sorted waste disposal.	1000	-15 / 40	No
0,37	2,18	0,00	1,26	0	0	0	0	0	1630				
0,55	2,74	0,00	1,58	0	0	0	0	0	1650				
0,75	3,15	3,13	1,82	1,81	1,81	1,80	1,05	1,04	1730 ÷ 1735				
1,1	4,78	4,80	2,76	2,77	2,74	2,74	1,58	1,58	1745 ÷ 1750				
1,5	6,69	6,77	3,86	3,91	3,87	3,92	2,23	2,26	1750 ÷ 1755				
2,2	8,6	8,57	4,98	4,95	4,95	4,92	2,86	2,84	1755 ÷ 1760				
3	12,5	12,6	7,20	7,26	7,00	7,02	4,04	4,05	1760 ÷ 1765				
4	15,3	15,2	8,82	8,78	8,80	8,72	5,08	5,03	1755 ÷ 1755				
5,5	20,9	20,6	12,1	11,9	12,2	12,0	7,04	6,91	1760 ÷ 1765				
7,5	27,9	27,6	16,1	15,9	16,2	16,0	9,34	9,21	1750 ÷ 1755				
11	37,9	37,9	21,9	21,9	21,9	21,5	12,6	12,4	1765 ÷ 1770				
15	52,9	53,4	30,6	30,8	30,2	29,9	17,4	17,3	1770 ÷ 1775				

** Operating conditions to be referred to motor only. About electric pump, refer to limits in user's manual.

sv-ie2-mott-4p60-en_a_te

e-SV™ SERIES

MOTOR NOISE AT 60 Hz, 4-POLE

The table show the mean sound pressure (Lp) measured as per Curve A (Standard ISO 1680).
 Noise values were measured with the 60 Hz motor running idle with a tolerance of 3 dB (A).

MOTORS AT 60 Hz, 4-POLE

POWER kW	MOTOR TYPE IEC SIZE	NOISE LpA dB
0,25	71	<70
0,37	71	<70
0,55	80	<70
0,75	80	<70
1,1	90	<70
1,5	90	<70
2,2	100	<70
3	100	<70
4	112	<70
5,5	132	<70
7,5	132	<70
11	160	<70
15	160	<70

1-125sv_mott-4p60_a_tr

AVAILABLE VOLTAGES MOTORS FOR e-SV™ SERIES (up to 22 kW)

P _N kW	IEC SIZE	SINGLE-PHASE								THREE-PHASE - 2 POLES																			
		50 Hz				60 Hz				50 Hz						60 Hz						50/60 Hz							
		1 x 220-240	1 x 100	1 x 110-120	1 x 220-230	1 x 100	1 x 110-115	1 x 120-127	1 x 200-210	3 x 220-230-240/380-400-415	3 x 380-400-415/660-690	3 x 200-208/346-360	3 x 255-265/440-460	3 x 290-300/500-525	3 x 440-460/-	3 x 500-525/-	3 x 220-230/380-400	3 x 255-265-277/440-460-480	3 x 380-400/660-690	3 x 440-460-480/-	3 x 110-115/190-200	3 x 200-208/346-360	3 x 330-346/575-600	3 x 575/-	3 x 230/400 50 Hz	3 x 265/460 60 Hz	3 x 400/690 50 Hz	3 x 460/- 60 Hz	
0,4	63	s	o	o	s	-	o	-	-	s	o	o	o	o	o	s	o	o	o	o	o	o	o	o	o	o	o	o	o
0,55	71	s	o	o	s	o	o	o	o	s	o	o	o	o	o	s	o	o	o	o	o	o	o	o	o	o	o	o	
0,75	71	s	o	o	s	o	o	o	o	s	o	o	o	o	o	s	o	o	o	o	o	o	o	o	o	o	o	o	
1,1	80	s	-	o	s	-	o	-	o	s	o	o	o	o	o	s	o	o	o	o	o	o	o	o	o	o	o	o	
1,5	80	s	-	-	s	-	o	-	o	s	o	o	o	o	o	s	o	o	o	o	o	o	o	o	o	o	o	o	
2,2	90	s	-	-	s	-	-	-	-	s	o	o	o	o	o	s	o	o	o	o	o	o	o	o	o	o	o	o	

s = Standard voltage o = Optional voltage

- = Not available

sv-volt-low-a-en_a_te

MOTORS FOR e-SV™ SERIES (≥ 30 kW)

PN kW	THREE-PHASE - 2 POLES																			
	50 Hz									60 Hz									50/60 Hz	
	3 x 220-230-240/380-400-415	3 x 380-400-415/660-690	3 x 110/190	3 x 200-208/346-360	3 x 255-265/440-460	3 x 290-300/500-525	3 x 440-460/-	3 x 500-525/-	3 x 230/380	3 x 380-400/660-690	3 x 440-480/-	3 x 110-115/190-200	3 x 200-208/346-360	3 x 255-265-277/440-460-480	3 x 330-346/575-600	3 x 575/-	3 x 230/400 50 Hz	3 x 265/460 60 Hz	3 x 400/690 50 Hz	3 x 460/- 60 Hz
30	o	s	o	o	o	o	o	o	s	o	o	o	o	o	o	o	o	o	o	
37	o	s	o	o	o	o	o	o	s	o	o	o	o	o	o	o	o	o	o	
45	o	s	o	o	o	o	o	o	s	o	o	o	o	o	o	o	o	o	o	
55	o	s	o	o	o	o	o	o	s	o	o	o	o	o	o	o	o	o	o	

s = Standard voltage o = Optional voltage

- = Not available

sv-volt-weg-en_b_te

PROTECTION SENSOR AGAINST DRY RUNNING

PROTECTION SENSOR AGAINST DRY RUNNING

Sensor for detecting the presence of water based on the optoelectronic principle, therefore non invasive and with no moving parts. The sensor provides an electronic contact to be used to stop the pump in the event of a lack of water in the seal area. The sensor opens the electronic contact after a factory-set delay (10 secs).

The sensor is supplied in a kit complete with 2m of cable, a gasket O-ring EPDM, and a stainless steel adapter.

The sensor can also be used in the following applications:



- Checking the level in water buffer tanks.
- Checking the level in pressure tanks.
- Checking leaks.

General using features

- The sensor is suitable for being connected directly on the filling cap of pumps in the e-SV™ series. An adapter cap is supplied for the 33..125SV series.
- Operation is independent of the hardness and conductivity of the water. The sensor is not suitable for detecting frozen liquids.

Available in different power supply versions:

- 21 ÷ 27 Vac, universal solid state output for 24 Vac external relay.
- 12 ÷ 28 Vdc, open NPN manifold outlet for Hydrovar® inverter.

Operating principle

Operation is based on the variation of the refractive index on the surfaces. The optic sensor comprises a glass cap with inserted a transmitter and an infrared receiver.

Mirror effect. In the absence of fluid, all the infrared light emitted is internally reflected by the surface of the glass cap of the receiver.

In the presence of fluid, the refractive index of the surface changes. Most of the emitted infrared light is dispersed in the fluid. The receiver receives less light, which causes the signal for presence of water.

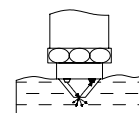
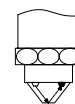
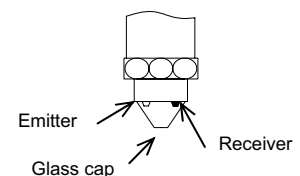

CHARACTERISTIC DATA

- Materials:
 - Body in AISI 316L stainless steel
 - Glass optic cap
 - EPDM gasket
 - Maximum pressure (PN): 25 bar (higher pressures on request).
 - Fluid: clean demineralised water, independent of hardness and conductivity. Compatible with other fluids such as oils (*).
 - Liquid temperature: $-20^{\circ}\text{C} \div 120^{\circ}\text{C}$. Ensure that the fluid always remains above freezing point.
 - Ambient temperature: $-5 \div +50^{\circ}\text{C}$
 - Continuous duty.
 - Alarm delay: 10 sec, set in the factory.
 - Connector: 3/8", included in the 3/8" – 1/2" adapter cap kit
 - Protection degree: IP55.
 - Electrical specifications:
 - Supply voltage: DC model: $12 \div 28 \text{ Vdc}$. AC model: $21 \div 27 \text{ Vac}$
 - Sensor maximum absorption: 20mA
 - Load maximum absorption: 50mA
 - DC model outlet: NPN open manifold, maximum 28Vdc, 50mA
 - AC model outlet: solid state outlet for general use in alternating current, maximum $21 \div 27 \text{ Vac}$, 50mA
 - Cable, included, type FROR 4 x 0,34 mm² (PVC-CEI 20-22) standard length 2m.
Cable working temperature: $-20^{\circ}\text{C} \div +70^{\circ}\text{C}$, fixed installation
 - Dimensions: 27x 60 mm
- (*) To check suitability for operating with a fluid such as oil, contact the Lowara technical support service and supply the characteristics of the fluid.

CONNECTION DIAGRAMS

Mechanical installation

The sensor may be fitted directly on the filling cap of e-SV pumps; for the series SV33..92, 125SV it is necessary to fit also a 3/8" – 1/2", included in the kit.

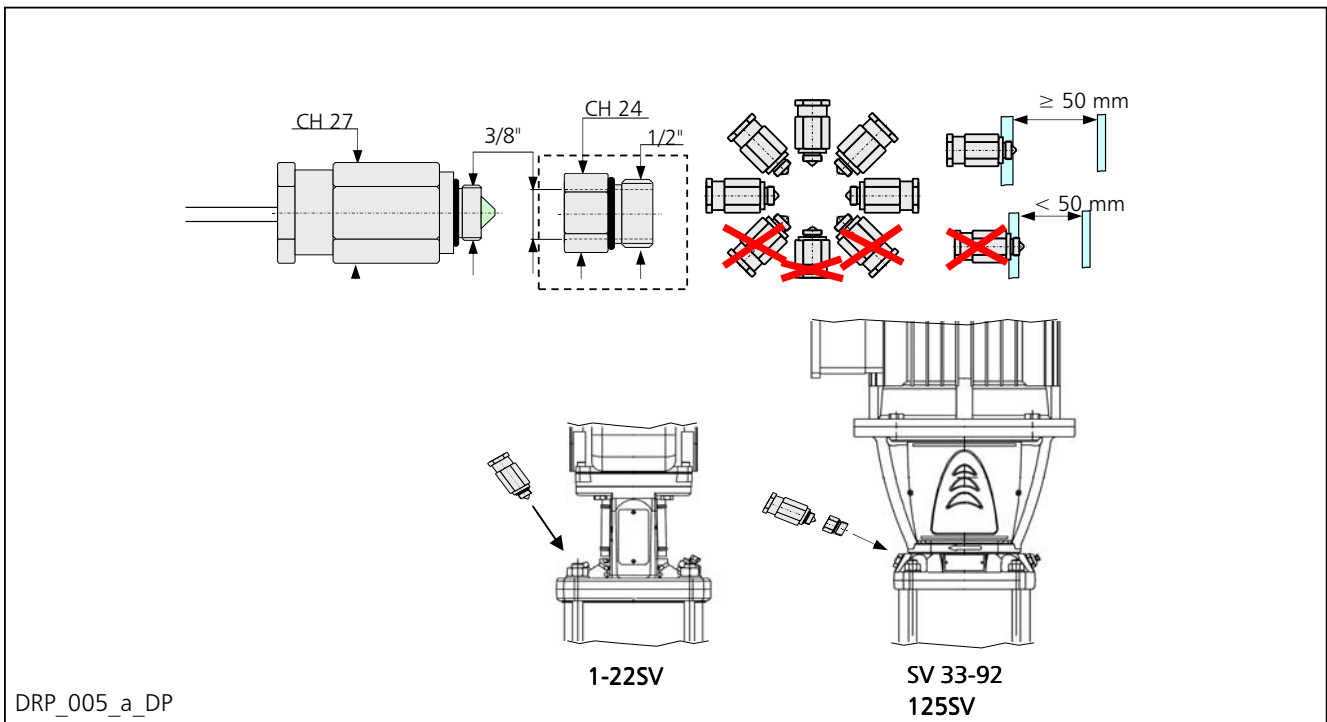

CONNECTION DIAGRAMS

- Direct current power supply 12 ÷ 28Vdc.
The sensor may be connected:

⇒ To the Hydrovar® directly on the terminal board X3. The sensor opens the NPN contact (black wire) 10 seconds (factory setting) after the water lack signal.

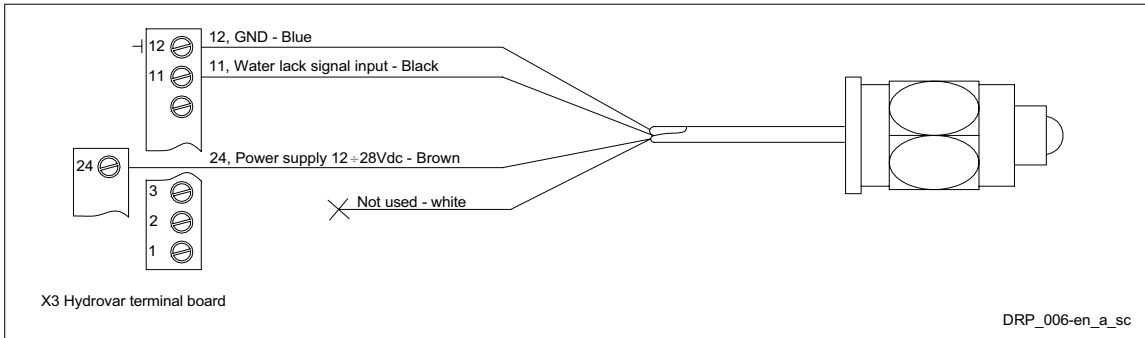

⇒ To a monitoring system (PLC), directly on the terminal board. A load resistance (pull-up) with a minimum value of 1kOhm must be fitted on the outside.

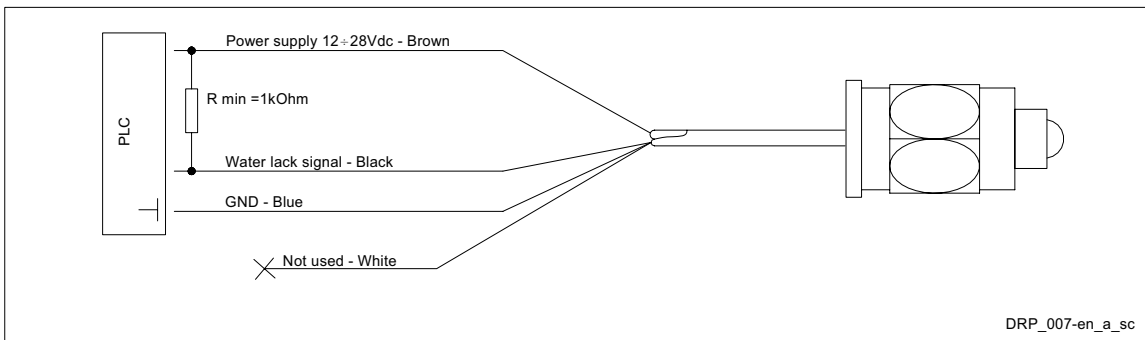

⇒ To a system with a relay and direct current power supply. A recirculating (free-wheeling) diode must be fitted on the outside.

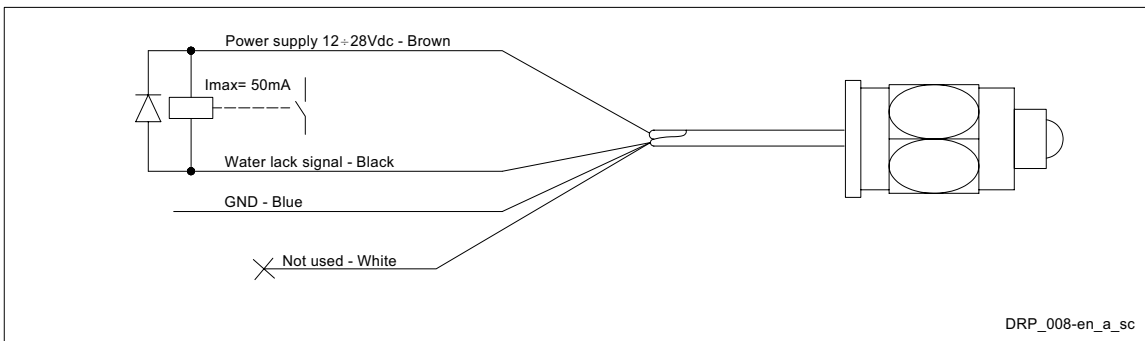

- General use, power supply 21 ÷ 27Vac.
The sensor may be connected to a system with a relay and alternating current power supply.

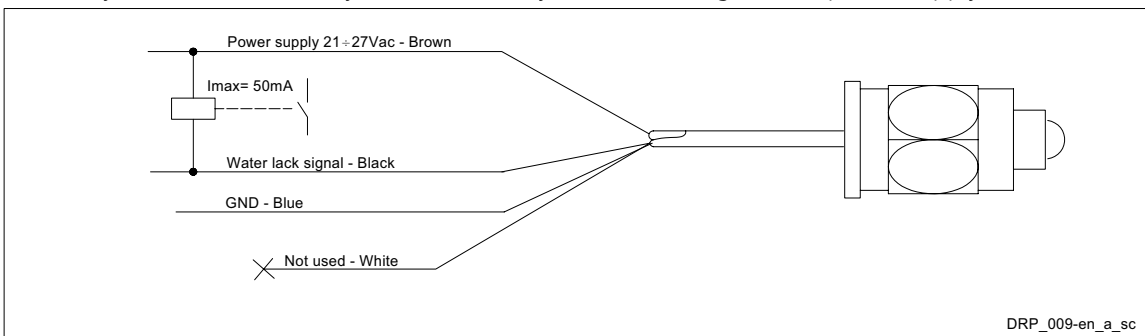

- For protection sensor code kit, please see the accessories section.

i-ALERT™

e-SV™ SERIES
i-Alert™ - CONDITIONAL MONITORING



i-Alert™ – The patent-pending condition monitoring device, originally intended for use within the Industrial Process market, is now incorporated within the e-SV product offering.

The device's onboard condition monitoring intelligence serves to reduce life cycle costs by increasing Mean time between failures (MTBF).

Features

- Continuously measures vibration – observing responses from the motor and the pump during operation.
- If pre-set limits are exceeded – the monitoring device alerts the end-user via blinking red LED. This allows the pump operator to make changes to the process or the pump before a catastrophic failure occurs.
- The i-Alert™ is also equipped with a single green LED to indicate when it is operational and has sufficient battery life.
- Both blinking green and red LED lights would be seen by operator or others during scheduled inspections or walk-bys.

Alarm Mode

- The condition monitor enters alarm mode when vibration limits are exceeded over two consecutive readings within a ten minute period. Alarm mode is indicated with two red flashing LEDs within two second intervals.
- Vibration limit: 100% increase over baseline or 0.5 in/sec max vibration levels. (Hydraulic Institute Standards, ISO 10816).
- Minimum vibration level to cause alarm mode is 3.175 mm/sec to minimize nuisance tripping.

Setup

- The condition monitor is ready for activation when the pump is running and has reached a steady flow, pressure, and temperature
- Place a small magnet on the condition monitor over the ITT logo and then remove it, as this example shows
- When the condition monitor is activated it:
 1. Displays a series of red LEDs followed by a solid green LED.
 2. Collects eight samples that are spaced one second apart.
 3. Averages these readings to establish the baseline vibration level.
 4. Flashes a green LED after approximately twelve seconds.

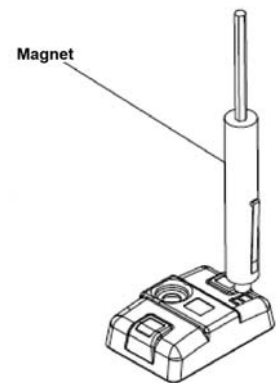

e-SV™ SERIES i-Alert™ - CONDITIONAL MONITORING

Monitoring Mode

- Measurement intervals for the condition monitor during normal operation and when the monitor is in alarm mode:

Mode	Measurement Interval
Normal (Green)	Five minutes
Alarm (Red)	Two minutes

- When the i-Alert™ measures a reading beyond the specified vibration limit, the appropriate red LED flashes. After the process or pump condition that causes the alarm is corrected, the i-Alert™ returns to normal mode after one normal-level measurement.

Possible Causes of Vibration

- Entrained air into the process fluid.
- Turbulence process flow within the system.
- Worn bearings (pump or motor)
- Water hammer
- Loose anchor / hold-down bolts
- Bent shaft / misalignment
- Harmonic vibration
- Unbalanced rotating equipment
- Many additional symptoms may cause elevated vibrations.

Battery Life

- The i-ALERT™ Condition Monitor battery is not replaceable. You must replace the entire unit once the battery runs out of power. Battery life is not covered by the standard pump warranty.

Mode	Battery Life
Normal (Green)	3 to 5 years
Alarm (Red)	1 year

Product Approval Standards

CSA certification

Intrinsically safe for:

- Class I, Div. 1, Groups A, B, C, D
- Class II, Div. 1, Groups E, F, G
- Class III
- Certified to Canadian and US requirements

Explosion-proofing standards

All explosion-proof products for use in explosive atmospheres are designed in compliance with one or more of the following approvals:

- EN, ATEX Directive 94/9/EC
- FM According to NEC
- Class 1 Div 1 Groups “C”, and “D”
- Class 2 Div 1 Groups “E”, “F”, and “G”
- Class 3 Div 1 Hazardous Locations

ATEX/IECEx:

- Group: IIC
- Category: Ex ia
- Temperature Class: T4 (for ambient up to 100°C)
- ATEX Marking: Ex II 1 G

- For i-Alert™ code kit, please see the accessories section.

CERTIFICATES

CERTIFICATES

Certificates

Description	Additional description	Standard of reference
Compliance of the shipment with order	without test	EN 10204 - 2.1
Compliance of the shipment with order	with non specific tests (material certificat)	EN 10204 - 2.2
CE declaration of conformity	Specific document In case of request after shipping, indicate matriculate number and production date	Machine directive 2006/42/EC
Manufacturer's declaration	Generic declaration for a family without specific indication of the pump data	/
Manufacturer's certificate of quality and quantity	Certification made on specific part numbers to declare the best quality of the processes, material and workforce for the production of the goods	/
3.1 Certificat (documents package) a) Test report ▶ 1A Factory Test Report (see table test 1A) ▶ 1B Lab (see table test 1B) b) List of materials c) Declaration of conformity d) Materials certificate (in contact with H ₂ O)		EN 10204 - 3.1
Other certificat/documentation on request (after verification of availability / feasibility)	WRAS, ACS, GOST...	
Duplicate of certification / documentation		

Test 1A

Description	Additional description	Standard of reference
Factory test report (1)	Q-H curve	ISO 9906 Annex A
Static test	Available only for: FH (no "F")- SH (no "F") - SV	ISO 9906 Annex A

(1) Factory test report not available for all product range. Please contact Customer Service

Test 1B

Description	Standard of reference
Performance certificate (Q-H curve - group efficiency - and group input power)	ISO 9906 Annex A

Test NPSH

Description	Standard of reference
NPSH test	ISO 9906 Annex A

Other Test

Description	Standard of reference
Noise test	UNI EN 12639:2002 UNI EN ISO 9614-2:1998 UNI EN ISO 11203:1997 UNI EN ISO 4871:1998
Vibration test	ISO 10816 ISO 5348

Certif-en_a_tc

ACCESSORIES

**G/SVH KIT
TABLE OF SIZES**

SVH series electric pump with hydraulic kit and G/SVH accessories, to realise a single-pump booster set which is quick and easy to install.

The hydraulic kit can be combined with the following SHV electric pumps:

- F versions (in-line ports, round flanges)
- R versions (overlapping ports, round flanges)
- N versions (in-line ports round flanges)
- G versions (in-line ports round flanges)

Assembly instructions inside the kit pack.

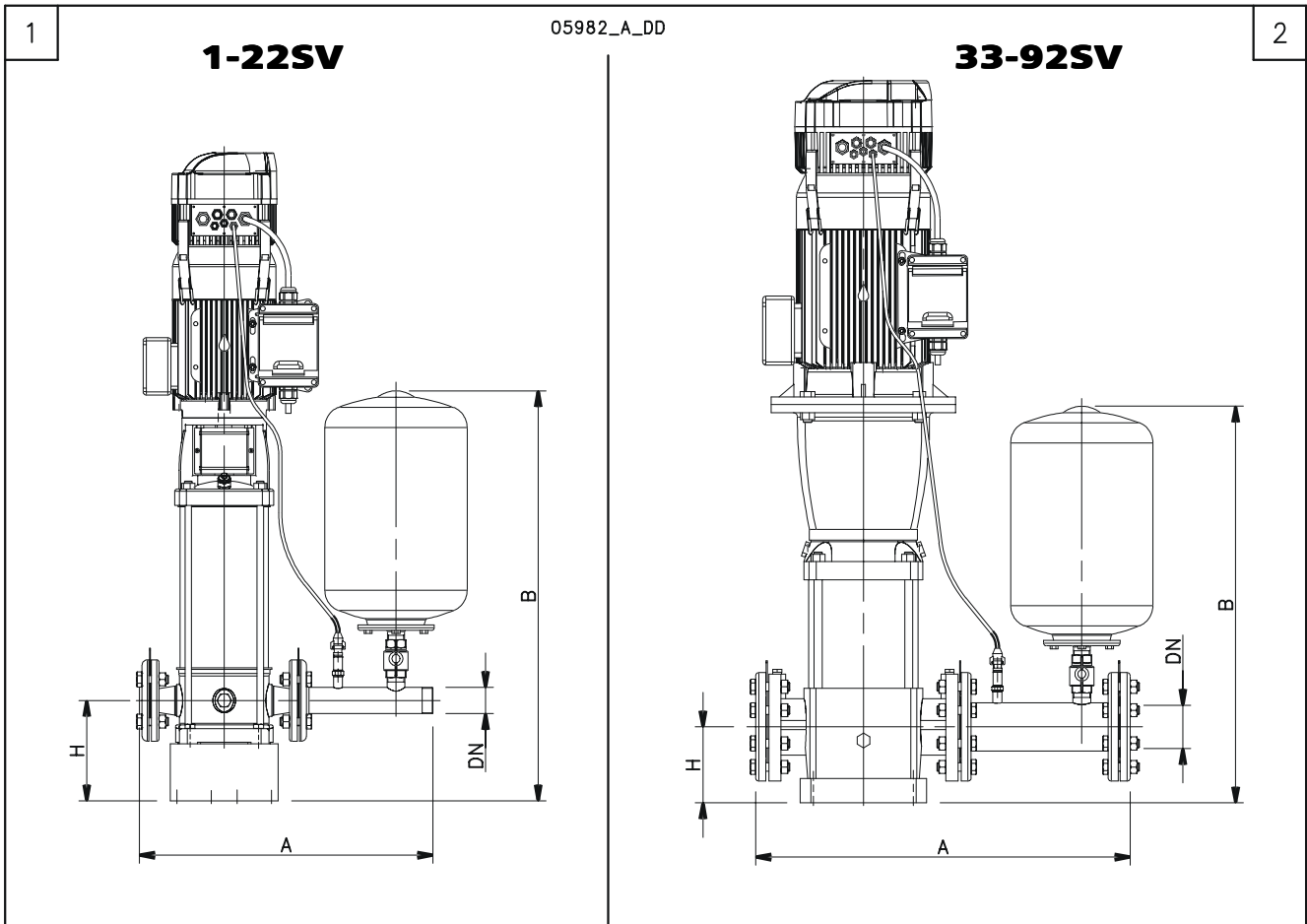

ACCESSORIES

TYPE	PUMP	DRW. N°	DIMENSIONS (mm)				
			DN	PN	H	A	B
G/SVH DN25 PN25	1SV - 3SV	1	25	25	180	524	744
G/SVH DN32 PN25	5SV	1	32	25	180	521	748
G/SVH DN40 PN25	10SV	1	40	25	185	557	756
G/SVH DN50 PN25	15SV - 22SV	1	50	25	195	637	772
G/SVH DN65 PN16	33SV	2	65	16	105	662	690
G/SVH DN65 PN25	33SV	2	65	25	105	674	690
G/SVH DN80 PN16	46SV	2	80	16	140	711	732
G/SVH DN80 PN25	46SV	2	80	25	140	723	732
G/SVH DN100 PN16	66SV - 92SV	2	100	16	140	744	744
G/SVH DN100 PN25	66SV - 92SV	2	100	25	140	744	744

Same dimensions for STANDARD, A304 and A316 versions.

g-sv-2p50-en_a_td

G/SVH KIT TABLE OF COMPONENTS

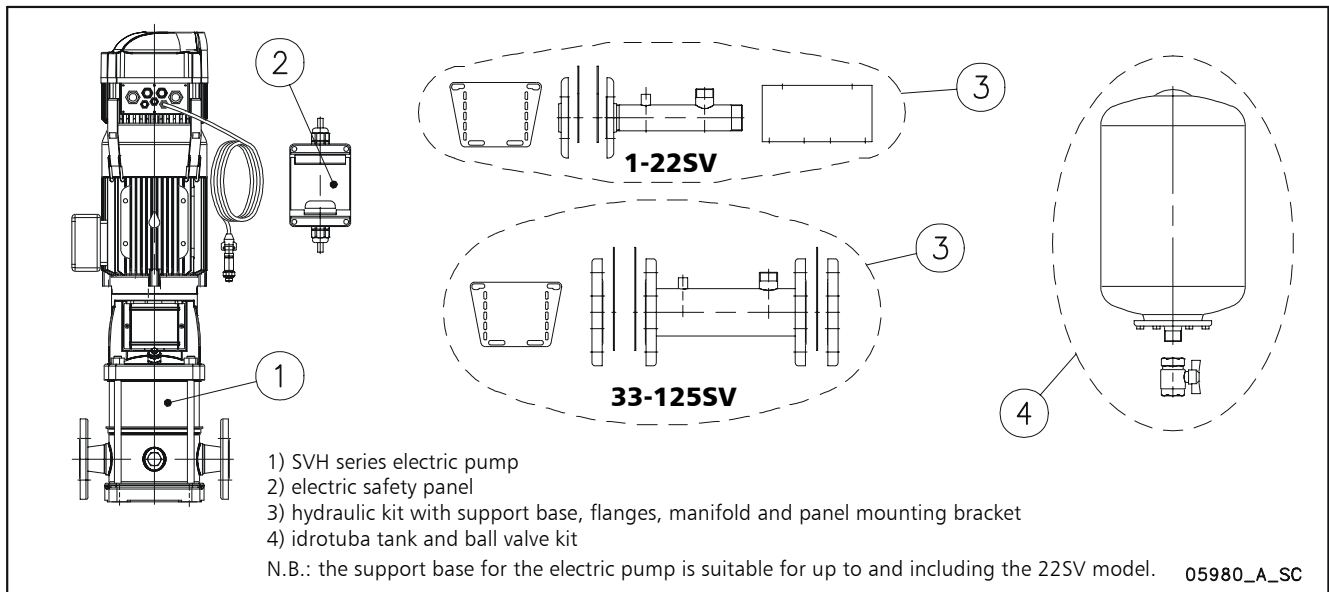

(1) PUMP TYPE	kW	VOLTAGE	(2) ELECTRIC PANEL	(3) HYDRAULIC STD KIT	(3) HYDRAULIC A304 KIT	(3) HYDRAULIC A316 KIT	(4) MEMBRANE TANK STD KIT	(4) MEMBRANE TANK A304 KIT
1SVH15..007	0,75	1x230 V	108212100	109422101	109422113	109422125	109391560	109391561
		3x400 V	108212300	109422101	109422113	109422125	109391560	-
1SVH22..011	1,1	1x230 V	108212100	109422101	109422113	109422125	109391570	-
		3x400 V	108212300	109422101	109422113	109422125	109391570	-
1SVH30..015	1,5	1x230 V	108212100	109422101	109422113	109422125	109395050	-
		3x400 V	108212300	109422101	109422113	109422125	109395050	-
1SVH37..022	2,2	1x230 V	108212100	109422101	109422113	109422125	109395050	-
		3x400 V	108212300	109422101	109422113	109422125	109395050	-
3SVH08..007	0,75	1x230 V	108212100	109422101	109422113	109422125	109391560	109391561
		3x400 V	108212300	109422101	109422113	109422125	109391560	109391561
3SVH12..011	1,1	1x230 V	108212100	109422101	109422113	109422125	109391560	109391561
		3x400 V	108212300	109422101	109422113	109422125	109391560	109391561
3SVH16..015	1,5	1x230 V	108212100	109422101	109422113	109422125	109391570	-
		3x400 V	108212300	109422101	109422113	109422125	109391570	-
3SVH21..022	2,2	1x230 V	108212100	109422101	109422113	109422125	109391570	-
		3x400 V	108212300	109422101	109422113	109422125	109391570	-
3SVH25..022	2,2	1x230 V	108212100	109422101	109422113	109422125	109395050	-
		3x400 V	108212300	109422101	109422113	109422125	109395050	-
3SVH29..030	3	3x400 V	108212300	109422101	109422113	109422125	109395050	-
		3x400 V	108212300	109422101	109422113	109422125	109395050	-
5SVH05..007	0,75	1x230 V	108212100	109422102	109422114	109422126	109391560	109391561
		3x400 V	108212300	109422102	109422114	109422126	109391560	109391561
5SVH08..011	1,1	1x230 V	108212100	109422102	109422114	109422126	109391560	109391561
		3x400 V	108212300	109422102	109422114	109422126	109391560	109391561
5SVH11..015	1,5	1x230 V	108212100	109422102	109422114	109422126	109391560	109391561
		3x400 V	108212300	109422102	109422114	109422126	109391560	109391561
5SVH14..022	2,2	1x230 V	108212100	109422102	109422114	109422126	109391570	-
		3x400 V	108212300	109422102	109422114	109422126	109391570	-
5SVH16..022	2,2	1x230 V	108212100	109422102	109422114	109422126	109391570	-
		3x400 V	108212300	109422102	109422114	109422126	109391570	-
5SVH21..030	3	3x400 V	108212300	109422102	109422114	109422126	109391570	-
5SVH28..040	4	3x400 V	108212300	109422102	109422114	109422126	109395050	-
5SVH33..055	5,5	3x400 V	108212400	109422102	109422114	109422126	109395050	-

1-5G_SVH-en_a_tc

G/SVH KIT TABLE OF COMPONENTS

(1) PUMP TYPE	KW	VOLTAGE	(2) ELECTRIC PANEL	(3) HYDRAULIC STD KIT	(3) HYDRAULIC A304 KIT	(3) HYDRAULIC A316 KIT	(4) MEMBRANE TANK STD KIT	(4) MEMBRANE TANK A304 KIT
10SVH04..015	1,5	1x230 V	108212100	109422103	109422115	109422127	109391560	109391561
		3x400 V	108212300	109422103	109422115	109422127	109391560	109391561
10SVH06..022	2,2	1x230 V	108212100	109422103	109422115	109422127	109391560	109391561
		3x400 V	108212300	109422103	109422115	109422127	109391560	109391561
10SVH08..030	3	3x400 V	108212300	109422103	109422115	109422127	109391560	109391561
10SVH11..040	4	3x400 V	108212300	109422103	109422115	109422127	109391570	-
10SVH15..055	5,5	3x400 V	108212400	109422103	109422115	109422127	109395050	-
10SVH20..075	7,5	3x400 V	108212500	109422103	109422115	109422127	109395050	-
10SVH21..110	11	3x400 V	108212600	109422103	109422115	109422127	109395050	-
15SVH02..022	2,2	1x230 V	108212100	109422104	109422116	109422128	109391560	109391561
		3x400 V	108212300	109422104	109422116	109422128	109391560	109391561
15SVH03..030	3	3x400 V	108212300	109422104	109422116	109422128	109391560	109391561
15SVH05..040	4	3x400 V	108212300	109422104	109422116	109422128	109391560	109391561
15SVH07..055	5,5	3x400 V	108212400	109422104	109422116	109422128	109391570	-
15SVH09..075	7,5	3x400 V	108212500	109422104	109422116	109422128	109391570	-
15SVH13..110	11	3x400 V	108212600	109422104	109422116	109422128	109395050	-
15SVH17..150	15	3x400 V	108212700	109422104	109422116	109422128	109395050	-
22SVH01..011	1,1	1x230 V	108212100	109422104	109422116	109422128	109391560	109391561
		3x400 V	108212300	109422104	109422116	109422128	109391560	109391561
22SVH03..030	3	3x400 V	108212300	109422104	109422116	109422128	109391560	109391561
22SVH04..040	4	3x400 V	108212300	109422104	109422116	109422128	109391560	109391561
22SVH05..055	5,5	3x400 V	108212400	109422104	109422116	109422128	109391560	109391561
22SVH07..075	7,5	3x400 V	108212500	109422104	109422116	109422128	109391570	-
22SVH10..110	11	3x400 V	108212600	109422104	109422116	109422128	109391570	-
22SVH14..150	15	3x400 V	108212700	109422104	109422116	109422128	109395050	-
33SVH1/1A..022	2,2	1x230 V	108212100	109422105	109422117	109422129	109391560	109391561
33SVH1..030	3	3x400 V	108212300	109422105	109422117	109422129	109391560	109391561
33SVH2..055	5,5	3x400 V	108212400	109422105	109422117	109422129	109391560	109391561
33SVH3..075	7,5	3x400 V	108212500	109422105	109422117	109422129	109391560	109391561
33SVH4..110	11	3x400 V	108212600	109422105	109422117	109422129	109391570	-
33SVH5..150	15	3x400 V	108212700	109422105	109422117	109422129	109391570	-
33SVH6..150	15	3x400 V	108212700	109422106	109422118	109422130	109391570	-
33SVH7..185	18,5	3x400 V	108212900	109422106	109422118	109422130	109395050	-
46SVH1..040	4	3x400 V	108212300	109422107	109422119	109422131	109391560	109391561
46SVH2..075	7,5	3x400 V	108212500	109422107	109422119	109422131	109391560	109391561
46SVH3..110	11	3x400 V	108212600	109422107	109422119	109422131	109391560	109391561
46SVH4..150	15	3x400 V	108212700	109422107	109422119	109422131	109391570	-
46SVH6..220	22	3x400 V	108212900	109422108	109422120	109422132	109391570	-
66SVH1..055	5,5	3x400 V	108212400	109422109	109422121	109422133	109391560	109391561
66SVH2..110	11	3x400 V	108212600	109422109	109422121	109422133	109391560	109391561
66SVH3..185	18,5	3x400 V	108212900	109422109	109422121	109422133	109391570	-
66SVH4..220	22	3x400 V	108212900	109422109	109422121	109422133	109391570	-
92SVH1..075	7,5	3x400 V	108212500	109422109	109422121	109422133	109391560	109391561
92SVH2..150	15	3x400 V	108212700	109422109	109422121	109422133	109391560	109391561
92SVH3..220	22	3x400 V	108212900	109422109	109422121	109422133	109391570	-

10-125G_SVH-en_a_tc

THREADED COUNTERFLANGES KIT (F, N, R, G SV) EN 1092-1

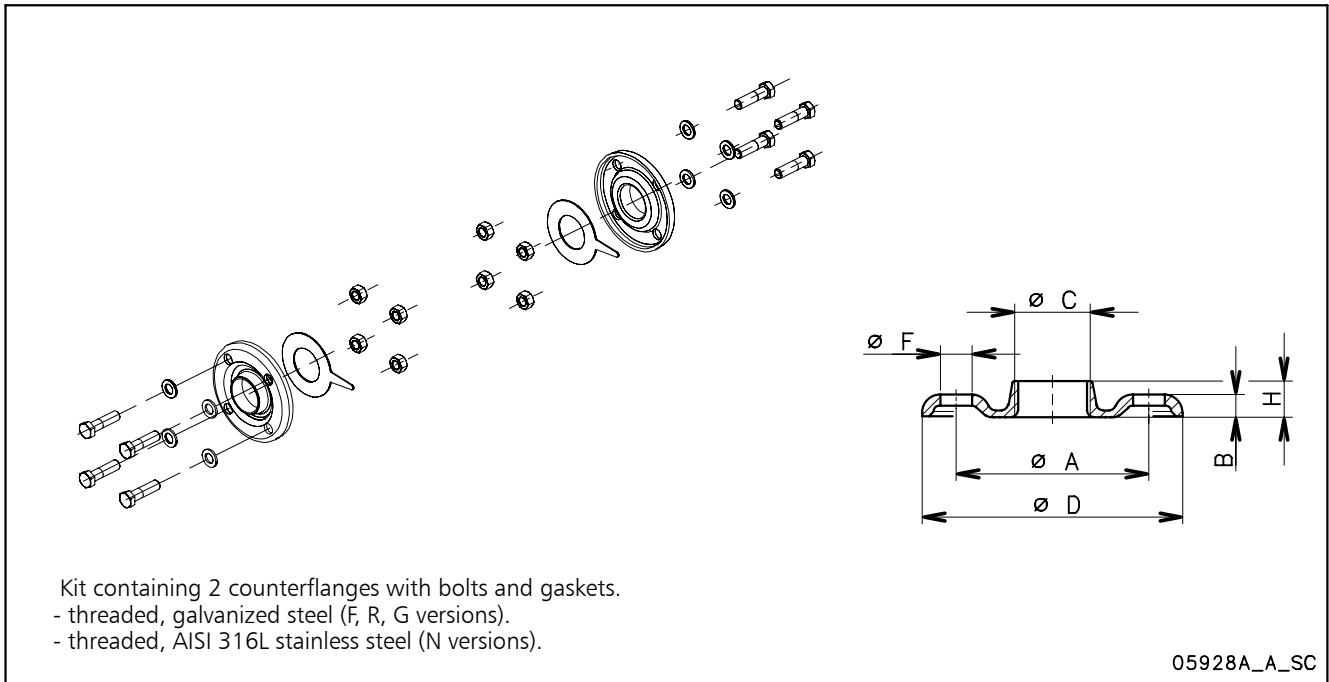

P.NUMBER	DESCRIPTION	PUMP TYPE	DN	ø C	DIMENSIONS (mm)				HOLES		
					ø A	B	ø D	H	ø F	N°	PN
109398000	KIT RP1" PN25 GALVANIZED STEEL	1-3SV	25	Rp 1	85	10	115	16	14	4	25
109398002	KIT RP1" PN25 AISI 316	1-3SV	25	Rp 1	85	10	115	16	14	4	25
109398010	KIT RP1"1/4 PN25 GALVANIZED STEEL	5SV	32	Rp 1 1/4	100	13	140	16	18	4	25
109398012	KIT RP1"1/4 PN25 AISI 316	5SV	32	Rp 1 1/4	100	13	140	16	18	4	25
109398020	KIT RP1"1/2 PN25 GALVANIZED STEEL	10SV	40	Rp 1 1/2	110	14	150	19	18	4	25
109398022	KIT RP1"1/2 PN25 AISI 316	10SV	40	Rp 1 1/2	110	14	150	19	18	4	25
109398030	KIT RP2" PN25 GALVANIZED STEEL	15-22SV	50	Rp 2	125	16	165	24	18	4	25
109398032	KIT RP2" PN25 AISI 316	15-22SV	50	Rp 2	125	16	165	24	18	4	25
109392710	KIT RP2"1/2 PN16 GALVANIZED STEEL	33SV	65	Rp 2 1/2	145	16	185	23	18	4	16
109392750	KIT RP2"1/2 PN16 AISI 316	33SV	65	Rp 2 1/2	145	16	185	23	18	4	16
109392720	KIT RP3" PN16 GALVANIZED STEEL	46SV	80	Rp 3	160	17	200	27	18	8	16
109392760	KIT RP3" PN16 AISI 316	46SV	80	Rp 3	160	17	200	27	18	8	16
109392730	KIT RP4" PN16 GALVANIZED STEEL	66SV-92SV	100	Rp 4	180	18	220	31	18	8	16
109392770	KIT RP4" PN16 AISI 316	66SV-92SV	100	Rp 4	180	18	220	31	18	8	16

kit_flg_fil-en_a_td

WELD-ON ROUND COUNTERFLANGES KIT (G, N SV) EN 1092-1

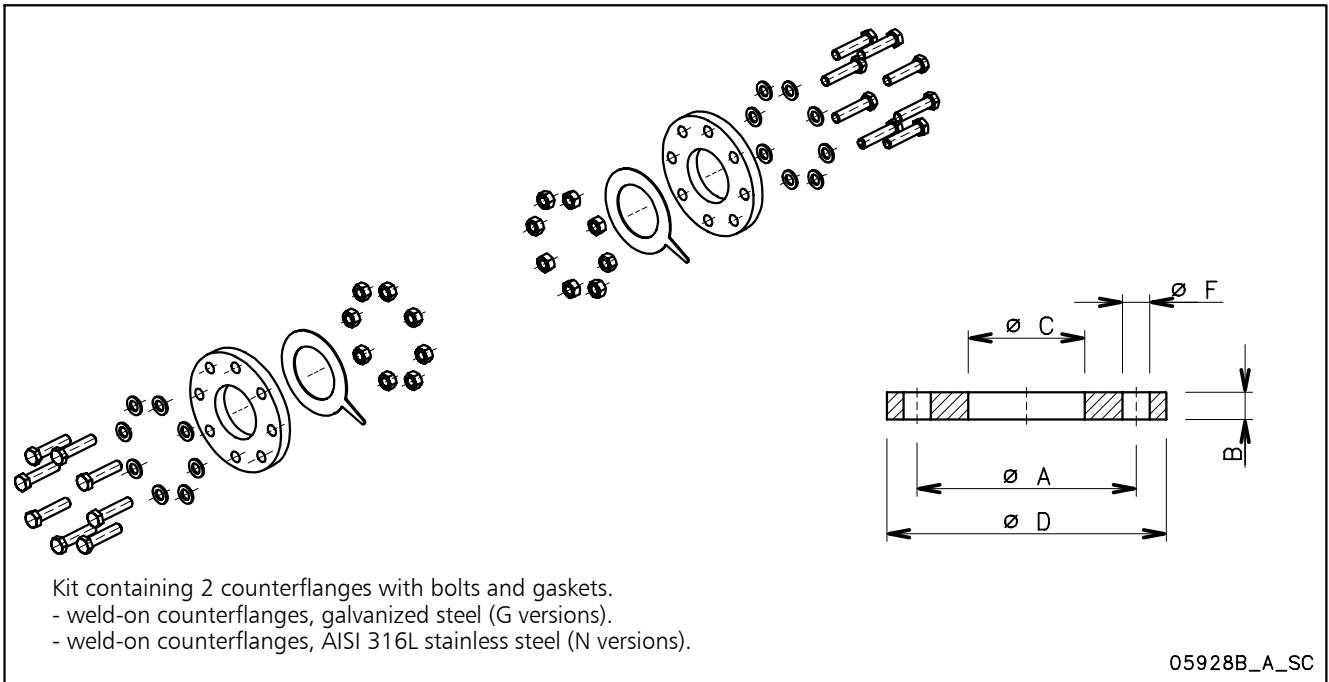

P.NUMBER	DESCRIPTION	PUMP TYPE	DN	$\varnothing C$	DIMENSIONS (mm)			HOLES		PN
					$\varnothing A$	B	$\varnothing D$	$\varnothing F$	N°	
109392800	KIT DN65 PN16 GALVANIZED STEEL	33SV	65	77	145	18	185	18	4	16
109392880	KIT DN65 PN16 AISI 316	33SV	65	77	145	18	185	18	4	16
109392840	KIT DN65 PN25-40 GALVANIZED STEEL	33SV	65	77	145	18	185	18	8	25-40
109392920	KIT DN65 PN25-40 AISI 316	33SV	65	77	145	18	185	18	8	25-40
109392810	KIT DN80 PN16 GALVANIZED STEEL	46SV	80	90	160	20	200	18	8	16
109392890	KIT DN80 PN16 AISI 316	46SV	80	90	160	20	200	18	8	16
109392850	KIT DN80 PN25-40 GALVANIZED STEEL	46SV	80	90	160	20	200	18	8	25-40
109392930	KIT DN80 PN25-40 AISI 316	46SV	80	90	160	20	200	18	8	25-40
109392820	KIT DN100 PN16 GALVANIZED STEEL	66-92SV	100	115,5	180	22	220	18	8	16
109392900	KIT DN100 PN16 AISI 316	66-92SV	100	115,5	180	22	220	18	8	16
109392860	KIT DN100 PN25-40 GALVANIZED STEEL	66-92SV	100	115,5	180	22	220	22	8	25-40
109392940	KIT DN100 PN25-40 AISI 316	66-92SV	100	115,5	180	22	220	22	8	25-40
109398080	KIT DN125 PN16 GALVANIZED STEEL	125SV	125	141	210	24	250	18	8	16
109398082	KIT DN125 PN16 AISI 316	125SV	125	141	210	24	250	18	8	16
109398090	KIT DN125 PN25-40 GALVANIZED STEEL	125SV	125	141	220	28	270	26	8	25-40
109398092	KIT DN125 PN25-40 AISI 316	125SV	125	141	220	28	270	26	8	25-40

kit_fig_sald-en_a_td

VICTAULIC® COUPLINGS KIT (V SV) MAXIMUM OPERATING PRESSURE 6900 kPa

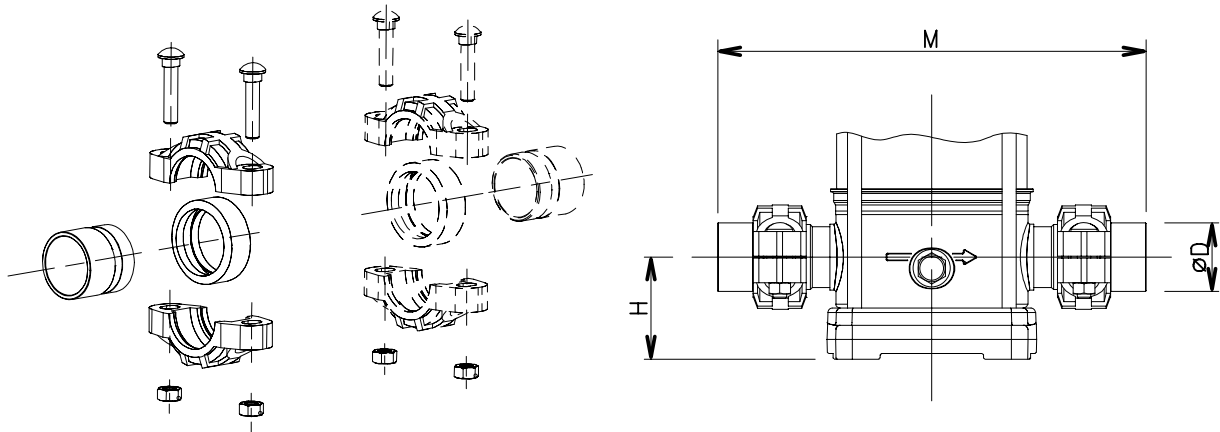

The single Kit includes: One cast iron Victaulic® coupling with one AISI 316L stainless steel weld-on or threaded sleeve with EPDM or FPM gasket.

The double Kit includes: Two cast iron Victaulic® couplings with two AISI 316L stainless steel weld-on or threaded sleeve with EPDM or FPM gasket.

05928C_A_SC

P.NUMBER	DESCRIPTION	PUMP TYPE	DIMENSIONS (mm)			
			DN	ø D	M	H
109390880	KIT SINGLE VICTAULIC THREADED R 1"1/4 EPDM	1-3-5SV V	DN32	R 1"1/4	320	75
109390980	KIT SINGLE VICTAULIC THREADED R 1"1/4 FPM	1-3-5SV V	DN32	R 1"1/4	320	75
109390890	KIT SINGLE VICTAULIC THREADED R 2" EPDM	10-15-22SV V	DN50	R 2"	378	90
109390990	KIT SINGLE VICTAULIC THREADED R 2" FPM	10-15-22SV V	DN50	R 2"	378	90
109390860	KIT SINGLE VICTAULIC DN32 WELD-ON EPDM	1-3-5SV V	DN32	42,2	320	75
109390960	KIT SINGLE VICTAULIC DN32 WELD-ON FPM	1-3-5SV V	DN32	42,2	320	75
109390870	KIT SINGLE VICTAULIC DN50 WELD-ON EPDM	10-15-22SV V	DN50	60,3	378	90
109390970	KIT SINGLE VICTAULIC DN50 WELD-ON FPM	10-15-22SV V	DN50	60,3	378	90
109398400	KIT DOUBLE VICTAULIC THREADED R 1"1/4 EPDM	1-3-5SV V	DN32	R 1"1/4	320	75
109398401	KIT DOUBLE VICTAULIC THREADED R 1"1/4 FPM	1-3-5SV V	DN32	R 1"1/4	320	75
109398410	KIT DOUBLE VICTAULIC THREADED R 2" EPDM	10-15-22SV V	DN50	R 2"	378	90
109398411	KIT DOUBLE VICTAULIC THREADED R 2" FPM	10-15-22SV V	DN50	R 2"	378	90
109398420	KIT DOUBLE VICTAULIC DN32 WELD-ON EPDM	1-3-5SV V	DN32	42,2	320	75
109398421	KIT DOUBLE VICTAULIC DN32 WELD-ON FPM	1-3-5SV V	DN32	42,2	320	75
109398430	KIT DOUBLE VICTAULIC DN50 WELD-ON EPDM	10-15-22SV V	DN50	60,3	378	90
109398431	KIT DOUBLE VICTAULIC DN50 WELD-ON FPM	10-15-22SV V	DN50	60,3	378	90

1-22sv-giunti-vict-en_b_td

VICTAULIC® COUPLINGS TANDEM KIT (SV P) MAXIMUM OPERATING PRESSURE 6900 kPa

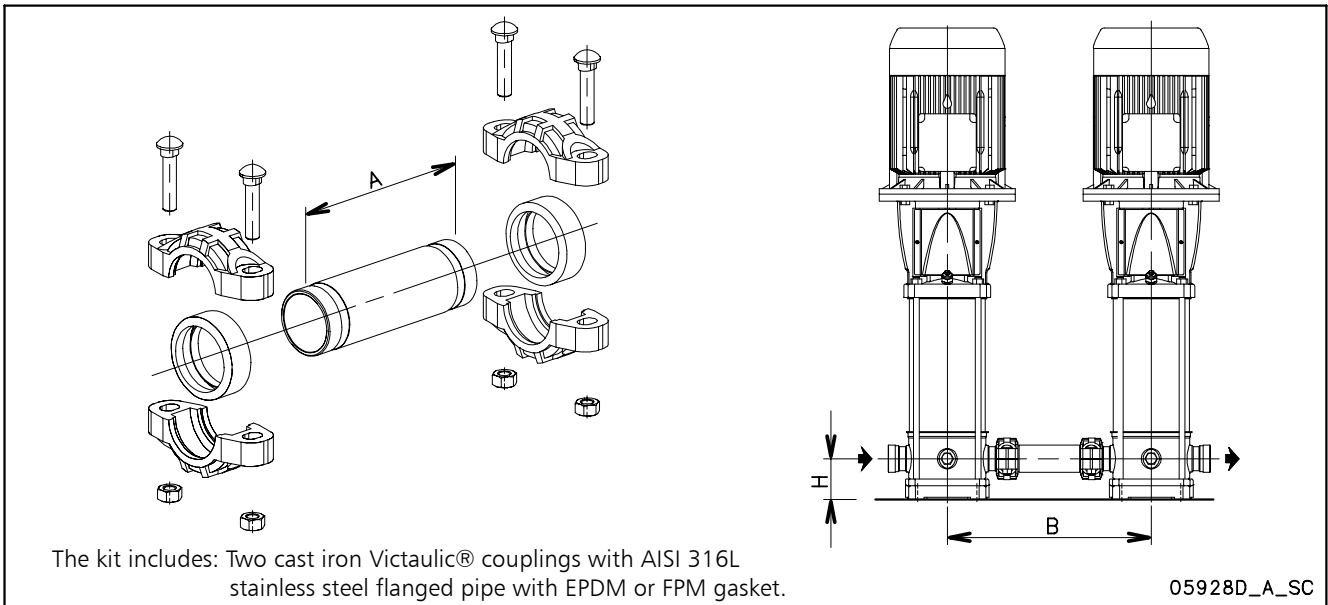

P.NUMBER	DESCRIPTION	PUMP TYPE	DIMENSIONS (mm)			
			DN	A	B	H
109398250	KIT TANDEM VICTAULIC DN32 EPDM	1-3-5SV V	DN32	134	350	75
109398251	KIT TANDEM VICTAULIC DN32 FPM	1-3-5SV V	DN32	134	350	75
109398260	KIT TANDEM VICTAULIC DN50 EPDM	10-15-22SV V	DN50	183	450	90
109398261	KIT TANDEM VICTAULIC DN50 FPM	10-15-22SV V	DN50	183	450	90

kit_tandem_vict-en_b_td

ROUND COUNTERFLANGES TANDEM KIT (SV P) MAXIMUM OPERATING PRESSURE 4500 kPa

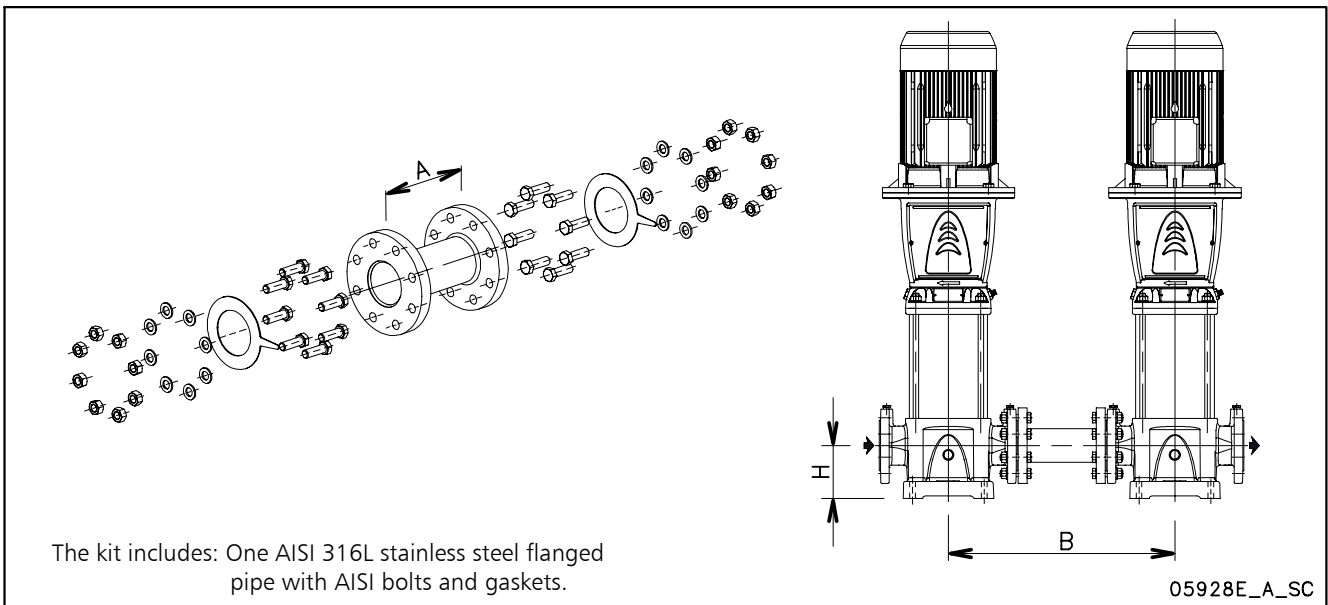

P.NUMBER	DESCRIPTION	PUMP TYPE	DIMENSIONS (mm)			
			DN	A	B	H
109398300	KIT TANDEM ROUND FLANGE DN65	33SV	DN65	176	500	105
109398310	KIT TANDEM ROUND FLANGE DN80	46SV	DN80	231	600	140
109398320	KIT TANDEM ROUND FLANGE DN100	66-92SV	DN100	281	650	140
109398330	KIT TANDEM ROUND FLANGE DN125	125SV	DN125	316	800	160

kit_tandem_round_flg-en_b_td

THREADED CLAMP KIT

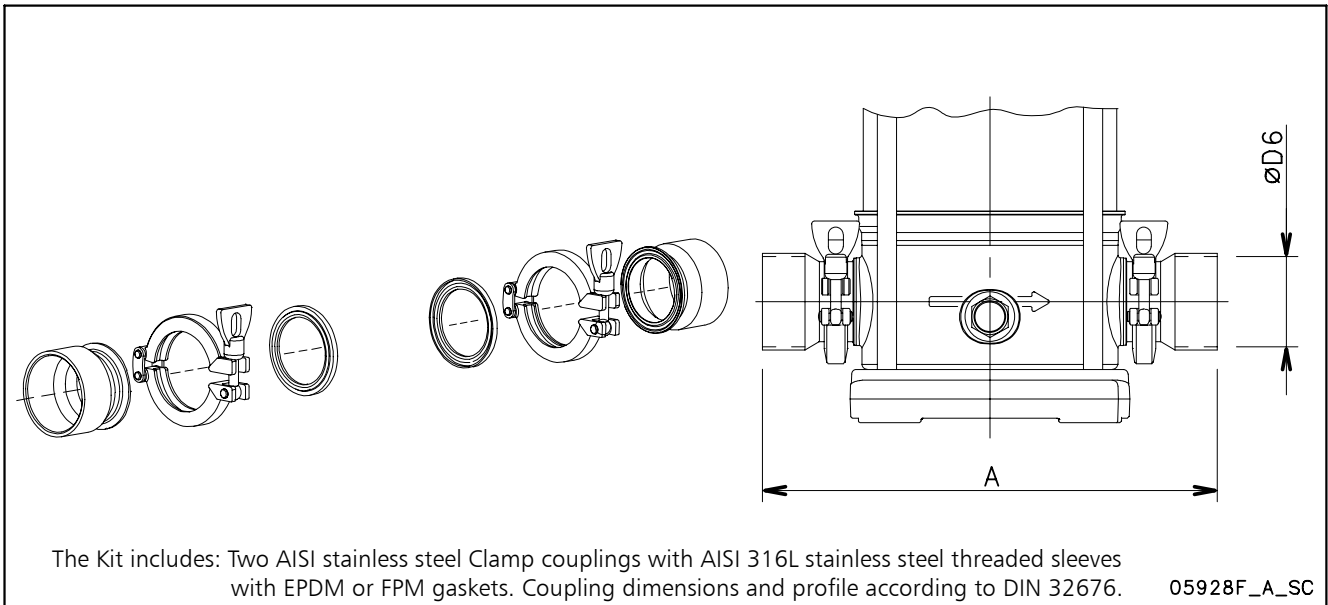

P.NUMBER	DESCRIPTION	PUMP TYPE	DIMENSIONS (mm)		
			DN	A	ø D6
109391860	KIT CLAMP DN32 THREADED RP 1"1/4 EPDM	1-3-5SV C	DN32	245	Rp 1"1/4
109391870	KIT CLAMP DN32 THREADED RP 1"1/4 FPM	1-3-5SV C	DN32	245	Rp 1"1/4
109391900	KIT CLAMP DN50 THREADED RP 2" EPDM	10-15-22SV C	DN50	301	Rp 2
109391910	KIT CLAMP DN50 THREADED RP 2" FPM	10-15-22SV C	DN50	301	Rp 2

kit-clamp_fill-en_a_td

WELD-ON CLAMP KIT

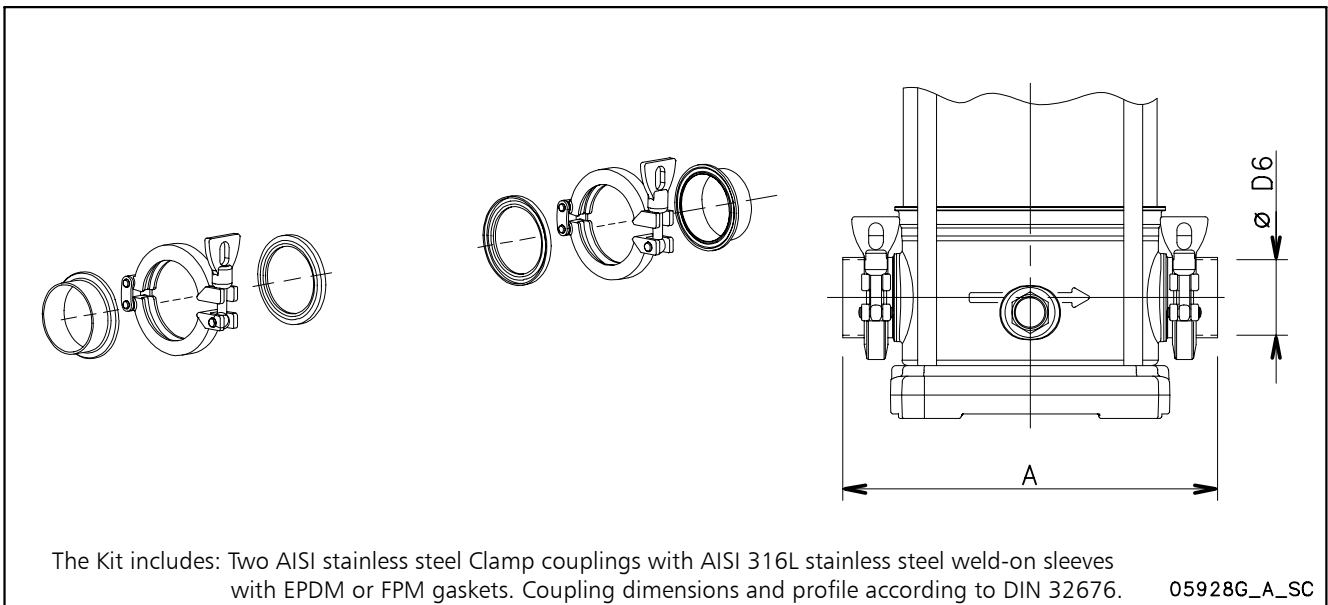

P.NUMBER	DESCRIPTION	PUMP TYPE	DIMENSIONS (mm)		
			DN	A	ø D6
109391880	KIT CLAMP DN32 WELD-ON EPDM	1-3-5SV C	DN32	245	35
109391890	KIT CLAMP DN32 WELD-ON FPM	1-3-5SV C	DN32	245	35
109391920	KIT CLAMP DN50 WELD-ON EPDM	10-15-22SV C	DN50	301	53
109391930	KIT CLAMP DN50 WELD-ON FPM	10-15-22SV C	DN50	301	53

kit-clamp_sald-en_a_td

HORIZONTAL VERSION BRACKET KIT (SV)

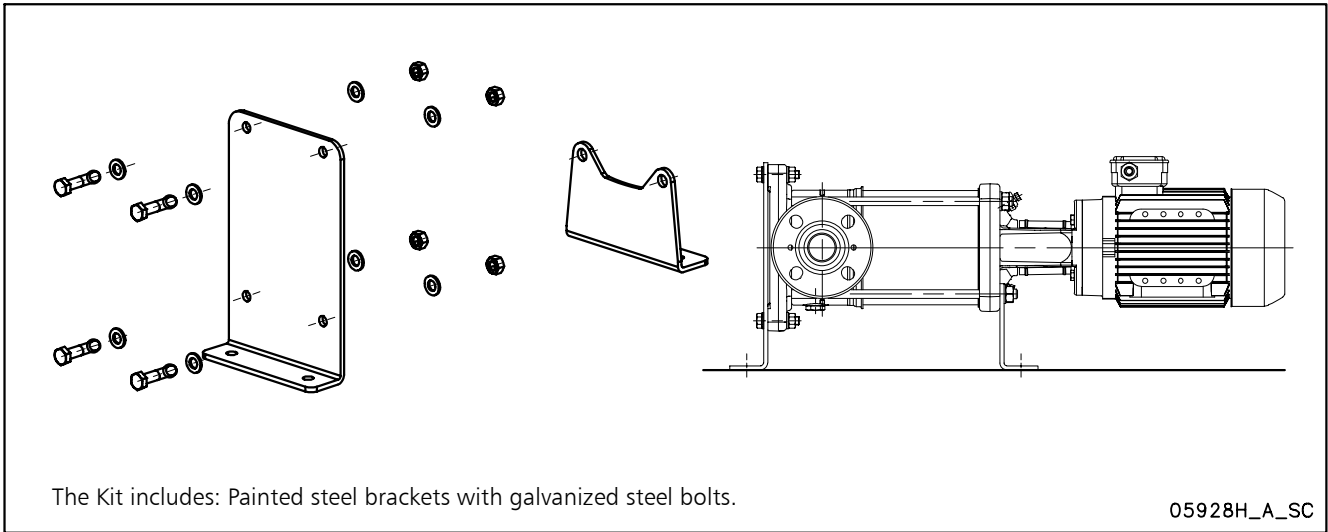

P.NUMBER	DESCRIPTION	MOTOR TYPE
148996700	BRACKET KIT 1-3-5SV F-N HORIZONTAL VERSION	LOWARA
148996710	BRACKET KIT 10-15-22SV F-N (0,75 ÷ 11 kW) HORIZONTAL VERSION	
148990700	BRACKET KIT 33SV G-N (1,1 ÷ 11 kW) HORIZONTAL VERSION	
148990760	BRACKET KIT 46SV G-N (1,1 ÷ 11 kW) HORIZONTAL VERSION	
148990770	BRACKET KIT 66-92SV G-N (1,1 ÷ 11 kW) HORIZONTAL VERSION	
148996800	BRACKET KIT 125SV G-N (7,5 kW) HORIZONTAL VERSION	

148996700-en_a_td

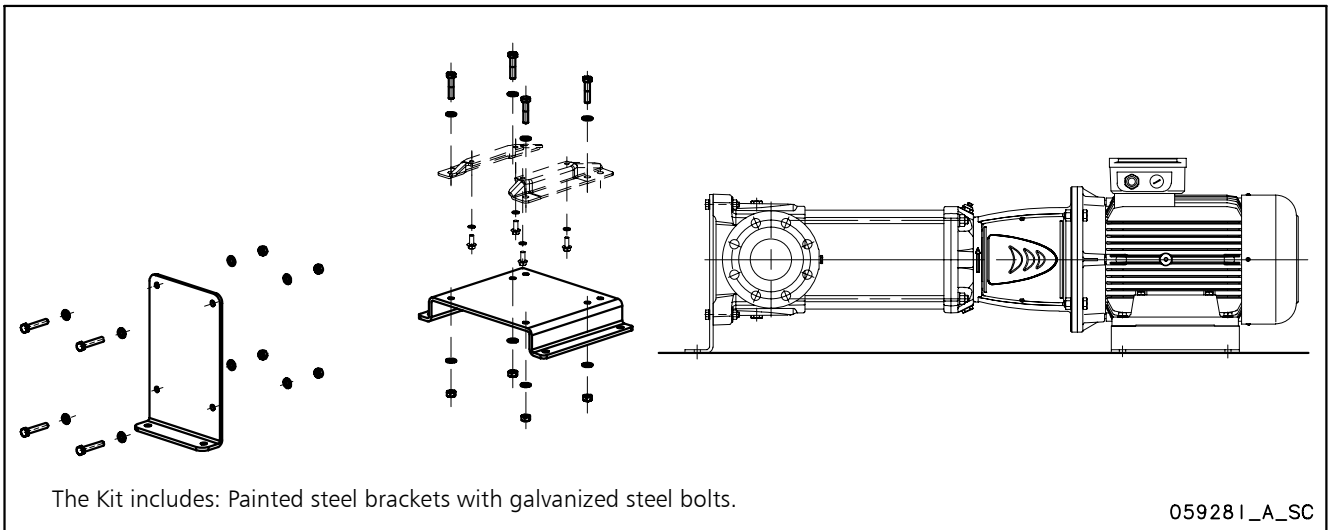

P.NUMBER	DESCRIPTION	MOTOR TYPE
148990920	BRACKET KIT 33SV G-N (15 ÷ 22 kW) HORIZONTAL VERSION	LOWARA
148990730	BRACKET KIT 33SV G-N (22 kW) HORIZONTAL VERSION	STANDARD B35 SIZE 180 (22kW)
148990930	BRACKET KIT 46-66-92SV G-N (15 ÷ 22 kW) HORIZONTAL VERSION	LOWARA
148990800	BRACKET KIT 46-66-92SV G-N (22 kW) HORIZONTAL VERSION	STANDARD B35 SIZE 180 (22kW)
148996810	BRACKET KIT 125SV G-N (15 ÷ 22 kW) HORIZONTAL VERSION	LOWARA
148996850	BRACKET KIT 125SV G-N (22 kW) HORIZONTAL VERSION	STANDARD B35 SIZE 180 (22kW)
148996820	BRACKET KIT 125SV G-N (30 ÷ 37 kW) HORIZONTAL VERSION	* WEG B35 SIZE 200
148996830	BRACKET KIT 125SV G-N (45 kW) HORIZONTAL VERSION	* WEG B35 SIZE 225

* FOR THESE MODELS CHANGE THE MOTOR FROM V1/B5 TO B35 CONSTRUCTION DESIGN.

148990920-en_a_td

HORIZONTAL VERSION BRACKET KIT (SV)

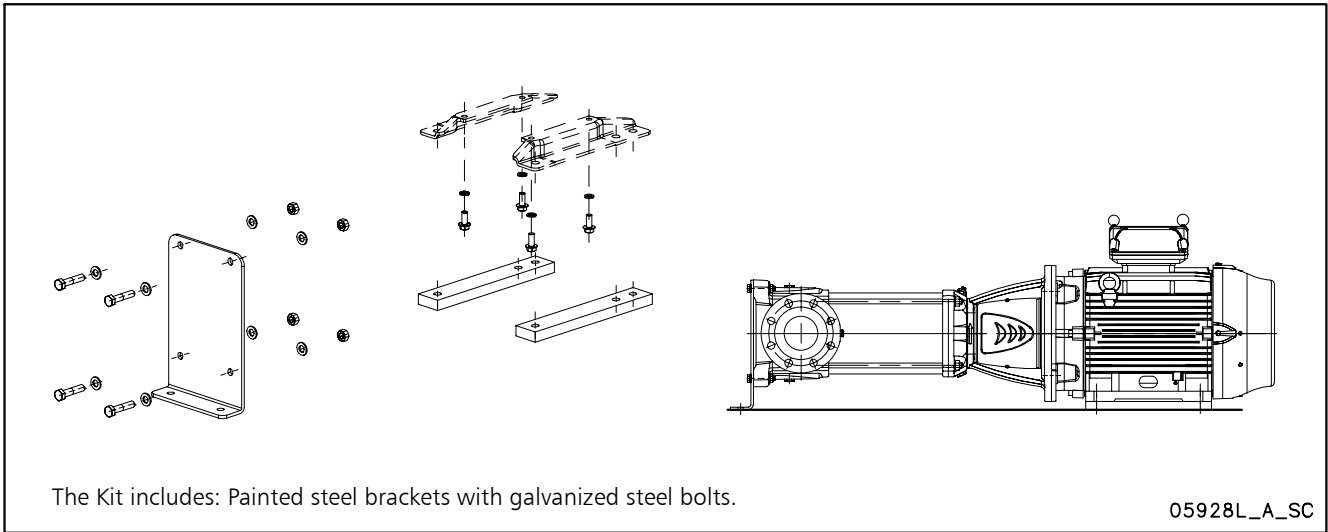

P.NUMBER	DESCRIPTION	MOTOR TYPE
148996720	BRACKET KIT 15-22SV F-N (15 ÷ 18,5 kW) HORIZONTAL VERSION	LOWARA
148990740	BRACKET KIT 33SV F-N (kW30 ÷ 37) HORIZONTAL VERSION	MARELLI SIZE 200
148996750	BRACKET KIT 33SV G-N (30 ÷ 37 kW) HORIZONTAL VERSION	* WEG B35 SIZE 200
148990810	BRACKET KIT 46-66-92SV F-N (kW30 ÷ 37) HORIZONTAL VERSION	MARELLI SIZE 200
148996760	BRACKET KIT 46-66-92SV G-N (30 ÷ 37 kW) HORIZONTAL VERSION	* WEG B35 SIZE 200
148990820	BRACKET KIT 46-66-92SV F-N (kW45) HORIZONTAL VERSION	MARELLI SIZE 225
148996770	BRACKET KIT 46-66-92SV G-N (45 kW) HORIZONTAL VERSION	* WEG B35 SIZE 225
148996840	BRACKET KIT 125SV G-N (55 kW) HORIZONTAL VERSION	* WEG B35 SIZE 250

* FOR THESE MODELS CHANGE THE MOTOR FROM V1/B5 TO B35 CONSTRUCTION DESIGN.

148996720-en_a_td

PROTECTION SENSOR AGAINST DRY RUNNING KIT (SV)

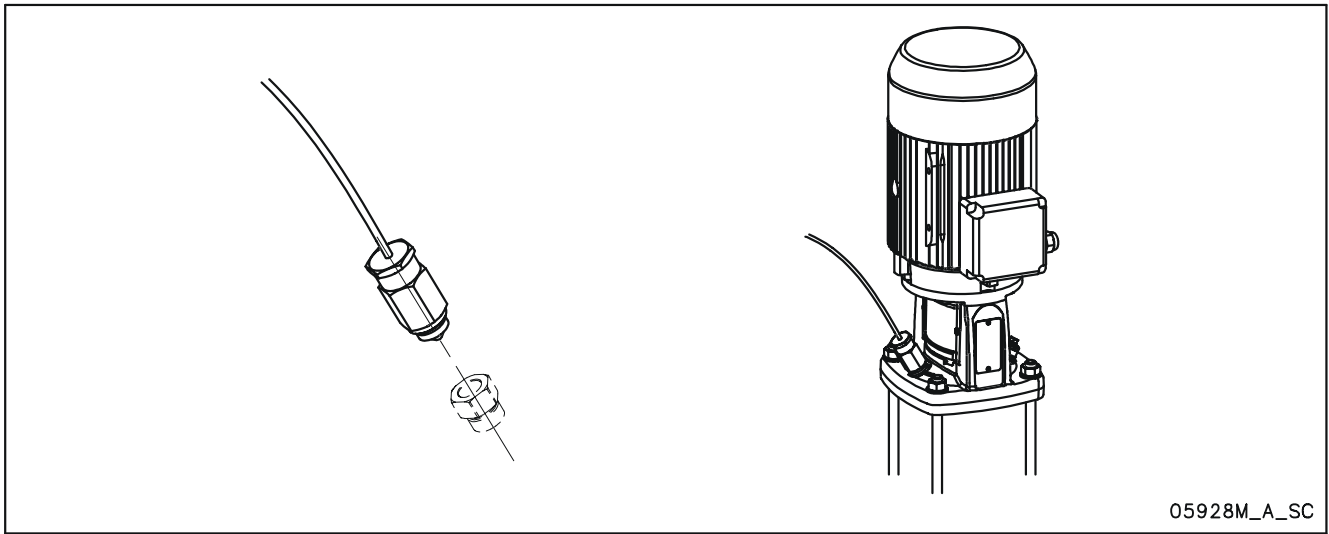

05928M_A_SC

P.NUMBER	DESCRIPTION	NOTE	PUMP TYPE
109394600	KIT SENSOR DRP-HV	POWER SUPPLY 15V DC FOR HYDROVAR	1-125 SV
109394610	KIT SENSOR DRP-GP	POWER SUPPLY 24V AC FOR GENERAL USE	1-125 SV

kit_sensor-en_a_td

I-ALERT™ KIT (SV)

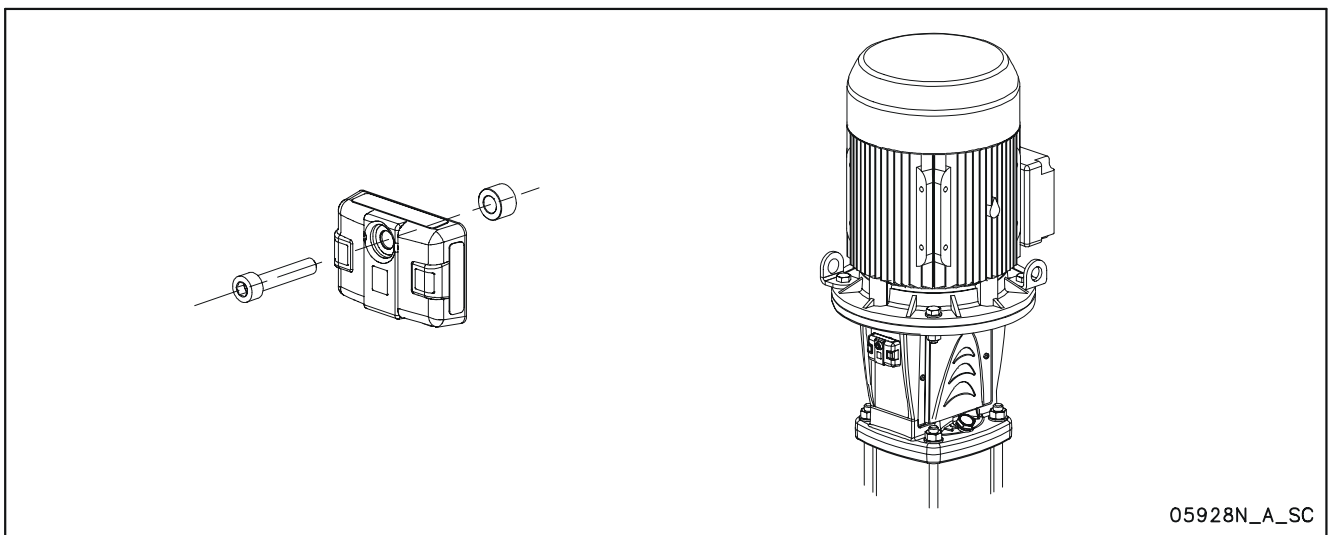

05928N_A_SC

P.NUMBER	DESCRIPTION	PUMP TYPE
109398200	KIT I-ALERT 1-125 SV	1-125 SV

kit_i-alert-en_a_td

TECHNICAL APPENDIX

NPSH

The minimum operating values that can be reached at the pump suction end are limited by the onset of cavitation.

Cavitation is the formation of vapour-filled cavities within liquids where the pressure is locally reduced to a critical value, or where the local pressure is equal to, or just below the vapour pressure of the liquid.

The vapour-filled cavities flow with the current and when they reach a higher pressure area the vapour contained in the cavities condenses. The cavities collide, generating pressure waves that are transmitted to the walls. These, being subjected to stress cycles, gradually become deformed and yield due to fatigue. This phenomenon, characterized by a metallic noise produced by the hammering on the pipe walls, is called incipient cavitation.

The damage caused by cavitation may be magnified by electrochemical corrosion and a local rise in temperature due to the plastic deformation of the walls. The materials that offer the highest resistance to heat and corrosion are alloy steels, especially austenitic steel. The conditions that trigger cavitation may be assessed by calculating the total net suction head, referred to in technical literature with the acronym NPSH (Net Positive Suction Head).

The NPSH represents the total energy (expressed in m.) of the liquid measured at suction under conditions of incipient cavitation, excluding the vapour pressure (expressed in m.) that the liquid has at the pump inlet.

To find the static height h_z at which to install the machine under safe conditions, the following formula must be verified:

$$h_p + h_z \geq (\text{NPSH}_r + 0.5) + h_f + h_{pv} \quad \textcircled{1}$$

where:

- h_p** is the absolute pressure applied to the free liquid surface in the suction tank, expressed in m. of liquid; h_p is the quotient between the barometric pressure and the specific weight of the liquid.
- h_z** is the suction lift between the pump axis and the free liquid surface in the suction tank, expressed in m.; h_z is negative when the liquid level is lower than the pump axis.
- h_f** is the flow resistance in the suction line and its accessories, such as: fittings, foot valve, gate valve, elbows, etc.
- h_{pv}** is the vapour pressure of the liquid at the operating temperature, expressed in m. of liquid. h_{pv} is the quotient between the Pv vapour pressure and the liquid's specific weight.
- 0,5** is the safety factor.

The maximum possible suction head for installation depends on the value of the atmospheric pressure (i.e. the elevation above sea level at which the pump is installed) and the temperature of the liquid.

To help the user, with reference to water temperature (4° C) and to the elevation above sea level, the following tables show the drop in hydraulic pressure head in relation to the elevation above sea level, and the suction loss in relation to temperature.

Water temperature (°C)	20	40	60	80	90	110	120
Suction loss (m)	0,2	0,7	2,0	5,0	7,4	15,4	21,5

Elevation above sea level (m)	500	1000	1500	2000	2500	3000
Suction loss (m)	0,55	1,1	1,65	2,2	2,75	3,3

Friction loss is shown in the tables at pages 256-257 of this catalogue. To reduce it to a minimum, especially in cases of high suction head (over 4-5 m.) or within the operating limits with high flow rates, we recommend using a suction line having a larger diameter than that of the pump's suction port. It is always a good idea to position the pump as close as possible to the liquid to be pumped.

Make the following calculation:

Liquid: water at ~15°C $\gamma = 1 \text{ kg/dm}^3$

Flow rate required: 25 m³/h

Head for required delivery: 70 m.

Suction lift: 3,5 m.

The selection is an 33SVG075T pump whose NPSH required value is, at 25 m³/h, di 2 m.

For water at 15 °C

$$h_p = P_a / \gamma = 10,33\text{m}, h_{pv} = P_v / \gamma = 0,174\text{m} (0,01701 \text{ bar})$$

The H_f flow resistance in the suction line with foot valves is ~ 1,2 m.

By substituting the parameters in formula $\textcircled{1}$ with the numeric values above, we have:

$$10,33 + (-3,5) \geq (2 + 0,5) + 1,2 + 0,17$$

from which we have: 6,8 > 3,9

The relation is therefore verified.

VAPOUR PRESSURE VAPOUR PRESSURE p_s AND ρ DENSITY OF WATER TABLE

t °C	T K	p_s bar	ρ kg/dm ³	t °C	T K	p_s bar	ρ kg/dm ³	t °C	T K	p_s bar	ρ kg/dm ³
0	273,15	0,00611	0,9998	55	328,15	0,15741	0,9857	120	393,15	1,9854	0,9429
1	274,15	0,00657	0,9999	56	329,15	0,16511	0,9852	122	395,15	2,1145	0,9412
2	275,15	0,00706	0,9999	57	330,15	0,17313	0,9846	124	397,15	2,2504	0,9396
3	276,15	0,00758	0,9999	58	331,15	0,18147	0,9842	126	399,15	2,3933	0,9379
4	277,15	0,00813	1,0000	59	332,15	0,19016	0,9837	128	401,15	2,5435	0,9362
5	278,15	0,00872	1,0000	60	333,15	0,1992	0,9832	130	403,15	2,7013	0,9346
6	279,15	0,00935	1,0000	61	334,15	0,2086	0,9826	132	405,15	2,867	0,9328
7	280,15	0,01001	0,9999	62	335,15	0,2184	0,9821	134	407,15	3,041	0,9311
8	281,15	0,01072	0,9999	63	336,15	0,2286	0,9816	136	409,15	3,223	0,9294
9	282,15	0,01147	0,9998	64	337,15	0,2391	0,9811	138	411,15	3,414	0,9276
10	283,15	0,01227	0,9997	65	338,15	0,2501	0,9805	140	413,15	3,614	0,9258
11	284,15	0,01312	0,9997	66	339,15	0,2615	0,9799	145	418,15	4,155	0,9214
12	285,15	0,01401	0,9996	67	340,15	0,2733	0,9793	155	428,15	5,433	0,9121
13	286,15	0,01497	0,9994	68	341,15	0,2856	0,9788	160	433,15	6,181	0,9073
14	287,15	0,01597	0,9993	69	342,15	0,2984	0,9782	165	438,15	7,008	0,9024
15	288,15	0,01704	0,9992	70	343,15	0,3116	0,9777	170	443,15	7,920	0,8973
16	289,15	0,01817	0,9990	71	344,15	0,3253	0,9770	175	448,15	8,924	0,8921
17	290,15	0,01936	0,9988	72	345,15	0,3396	0,9765	180	453,15	10,027	0,8869
18	291,15	0,02062	0,9987	73	346,15	0,3543	0,9760	185	458,15	11,233	0,8815
19	292,15	0,02196	0,9985	74	347,15	0,3696	0,9753	190	463,15	12,551	0,8760
20	293,15	0,02337	0,9983	75	348,15	0,3855	0,9748	195	468,15	13,987	0,8704
21	294,15	0,24850	0,9981	76	349,15	0,4019	0,9741	200	473,15	15,550	0,8647
22	295,15	0,02642	0,9978	77	350,15	0,4189	0,9735	205	478,15	17,243	0,8588
23	296,15	0,02808	0,9976	78	351,15	0,4365	0,9729	210	483,15	19,077	0,8528
24	297,15	0,02982	0,9974	79	352,15	0,4547	0,9723	215	488,15	21,060	0,8467
25	298,15	0,03166	0,9971	80	353,15	0,4736	0,9716	220	493,15	23,198	0,8403
26	299,15	0,03360	0,9968	81	354,15	0,4931	0,9710	225	498,15	25,501	0,8339
27	300,15	0,03564	0,9966	82	355,15	0,5133	0,9704	230	503,15	27,976	0,8273
28	301,15	0,03778	0,9963	83	356,15	0,5342	0,9697	235	508,15	30,632	0,8205
29	302,15	0,04004	0,9960	84	357,15	0,5557	0,9691	240	513,15	33,478	0,8136
30	303,15	0,04241	0,9957	85	358,15	0,5780	0,9684	245	518,15	36,523	0,8065
31	304,15	0,04491	0,9954	86	359,15	0,6011	0,9678	250	523,15	39,776	0,7992
32	305,15	0,04753	0,9951	87	360,15	0,6249	0,9671	255	528,15	43,246	0,7916
33	306,15	0,05029	0,9947	88	361,15	0,6495	0,9665	260	533,15	46,943	0,7839
34	307,15	0,05318	0,9944	89	362,15	0,6749	0,9658	265	538,15	50,877	0,7759
35	308,15	0,05622	0,9940	90	363,15	0,7011	0,9652	270	543,15	55,058	0,7678
36	309,15	0,05940	0,9937	91	364,15	0,7281	0,9644	275	548,15	59,496	0,7593
37	310,15	0,06274	0,9933	92	365,15	0,7561	0,9638	280	553,15	64,202	0,7505
38	311,15	0,06624	0,9930	93	366,15	0,7849	0,9630	285	558,15	69,186	0,7415
39	312,15	0,06991	0,9927	94	367,15	0,8146	0,9624	290	563,15	74,461	0,7321
40	313,15	0,07375	0,9923	95	368,15	0,8453	0,9616	295	568,15	80,037	0,7223
41	314,15	0,07777	0,9919	96	369,15	0,8769	0,9610	300	573,15	85,927	0,7122
42	315,15	0,08198	0,9915	97	370,15	0,9094	0,9602	305	578,15	92,144	0,7017
43	316,15	0,09639	0,9911	98	371,15	0,9430	0,9596	310	583,15	98,70	0,6906
44	317,15	0,09100	0,9907	99	372,15	0,9776	0,9586	315	588,15	105,61	0,6791
45	318,15	0,09582	0,9902	100	373,15	1,0133	0,9581	320	593,15	112,89	0,6669
46	319,15	0,10086	0,9898	102	375,15	1,0878	0,9567	325	598,15	120,56	0,6541
47	320,15	0,10612	0,9894	104	377,15	1,1668	0,9552	330	603,15	128,63	0,6404
48	321,15	0,11162	0,9889	106	379,15	1,2504	0,9537	340	613,15	146,05	0,6102
49	322,15	0,11736	0,9884	108	381,15	1,3390	0,9522	350	623,15	165,35	0,5743
50	323,15	0,12335	0,9880	110	383,15	1,4327	0,9507	360	633,15	186,75	0,5275
51	324,15	0,12961	0,9876	112	385,15	1,5316	0,9491	370	643,15	210,54	0,4518
52	325,15	0,13613	0,9871	114	387,15	1,6362	0,9476	374,15	647,30	221,20	0,3154
53	326,15	0,14293	0,9862	116	389,15	1,7465	0,9460				
54	327,15	0,15002	0,9862	118	391,15	1,8628	0,9445				

G-at_npsb_sc

FLOW RESISTANCE

TABLE OF FLOW RESISTANCE IN BENDS, VALVES AND GATES

The flow resistance is calculated using the equivalent pipeline length method according to the table below:

ACCESSORY TYPE	DN											
	25	32	40	50	65	80	100	125	150	200	250	300
	Equivalent pipeline length (m)											
45° bend	0,2	0,2	0,4	0,4	0,6	0,6	0,9	1,1	1,5	1,9	2,4	2,8
90° bend	0,4	0,6	0,9	1,1	1,3	1,5	2,1	2,6	3,0	3,9	4,7	5,8
90° smooth bend	0,4	0,4	0,4	0,6	0,9	1,1	1,3	1,7	1,9	2,8	3,4	3,9
Union tee or cross	1,1	1,3	1,7	2,1	2,6	3,2	4,3	5,3	6,4	7,5	10,7	12,8
Gate	-	-	-	0,2	0,2	0,2	0,4	0,4	0,6	0,9	1,1	1,3
Non return valve	1,1	1,5	1,9	2,4	3,0	3,4	4,7	5,9	7,4	9,6	11,8	13,9

G-a-pcv-en_a_th

The table is valid for the Hazen Williams coefficient $C=100$ (cast iron pipework);

for steel pipework, multiply the values by 1,41;

for stainless steel, copper and coated cast iron pipework, multiply the values by 1,85;

When the **equivalent pipeline length** has been determined, the flow resistance is obtained from the table of flow resistance.

The values given are guideline values which are bound to vary slightly according to the model, especially for gate valves and non-return valves, for which it is a good idea to check the values supplied by manufacturers.

VOLUMETRIC CAPACITY

Litres per minute l/min	Cubic metres per hour m ³ /h	Cubic feet per hour ft ³ /h	Cubic feet per minute ft ³ /min	Imp. gal. per minute Imp. gal./min	US gal. per minute Us gal./min
1,000	0,0600	2,1189	0,0353	0,2200	0,2642
16,6667	1,000	35,3147	0,5886	3,6662	4,4029
0,4719	0,0283	1,000	0,0167	0,1038	0,1247
28,3168	1,6990	60,0000	1,000	6,2288	7,4805
4,5461	0,2728	9,6326	0,1605	1,000	1,2009
3,7854	0,2271	8,0208	0,1337	0,8327	1,000

PRESSURE AND HEAD

Newton per square metre N/m ²	kilo Pascal kPa	bar bar	Pound force per square inch psi	metre of water m H ₂ O	millimetre of mercury mm Hg
1,000	0,0010	1 x 10 ⁻⁵	1.45 x 10 ⁻⁴	1.02 x 10 ⁻⁴	0,0075
1000,0000	1,000	0,0100	0,1450	0,1020	7,5006
1 x 10 ⁵	100,0000	1,000	14,5038	10,1972	750,0638
6894,7570	6,8948	0,0689	1,000	0,7031	51,7151
9806,6500	9,8067	0,0981	1,4223	1,000	73,5561
133,3220	0,1333	0,0013	0,0193	0,0136	1,000

LENGTH

millimetre mm	centimetre cm	metre m	inch in	foot ft	yard yd
1,000	0,1000	0,0010	0,0394	0,0033	0,0011
10,0000	1,000	0,0100	0,3937	0,0328	0,0109
1000,0000	100,0000	1,000	39,3701	3,2808	1,0936
25,4000	2,5400	0,0254	1,000	0,0833	0,0278
304,8000	30,4800	0,3048	12,0000	1,000	0,3333
914,4000	91,4400	0,9144	36,0000	3,0000	1,000

VOLUME

cubic metre m ³	litre litro	millilitre ml	imp. Gallon imp. gal.	US gallon US gal.	cubic foot ft ³
1,000	1000,0000	1 x 10 ⁶	219,9694	264,1720	35,3147
0,0010	1,000	1000,0000	0,2200	0,2642	0,0353
1 x 10 ⁻⁶	0,0010	1,000	2.2 x 10 ⁻⁴	2.642 x 10 ⁻⁴	3.53 x 10 ⁻⁵
0,0045	4,5461	4546,0870	1,000	1,2009	0,1605
0,0038	3,7854	3785,4120	0,8327	1,000	0,1337
0,0283	28,3168	28316,8466	6,2288	7,4805	1,000

G-at_pp-en_a_sc

FURTHER PRODUCT SELECTION AND DOCUMENTATION

Xylect

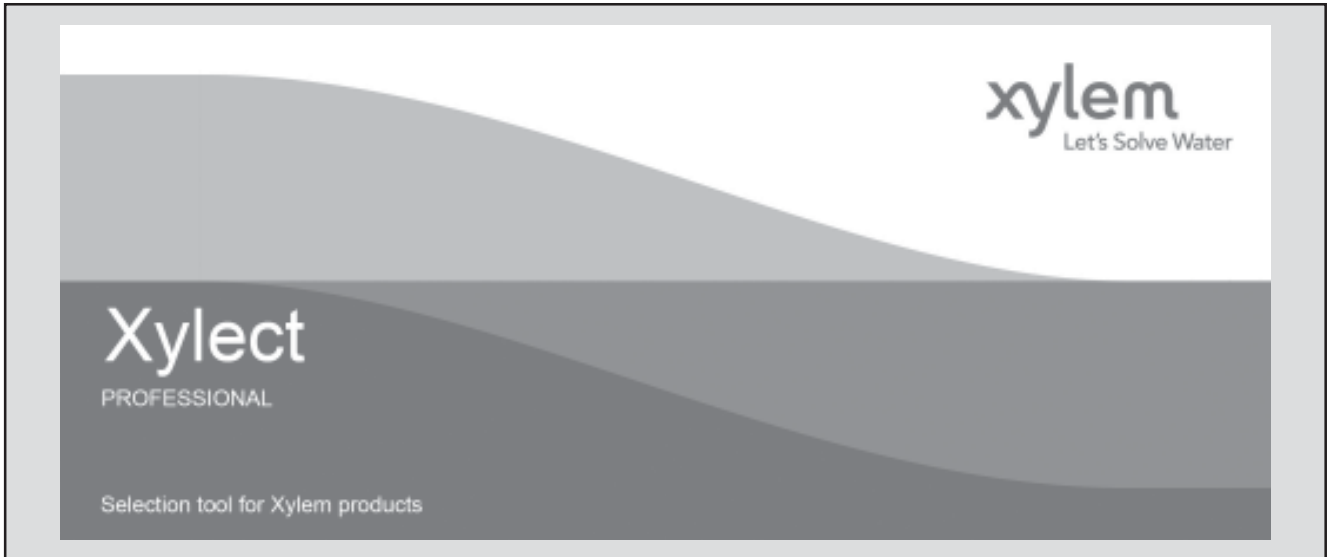

Xylect is pump solution selection software with an extensive online database of product information across the entire Lowara, and Vogel range of pumps and related products, with multiple search options and helpful project management facilities. The system holds up-to-date product information on thousands of products and accessories.

The possibility to search by applications and the detailed information output given makes it easy to make the optimal selection without having detailed knowledge about the Lowara and Vogel products.

The search can be made by:

- Application
- Product type
- Duty point

Xylect gives a detailed output:

- List with search results
- Performance curves (flow, head, power, efficiency, NPSH)
- Motor data
- Dimensional drawings
- Options
- Data sheet printouts
- Document downloads incl dxf files

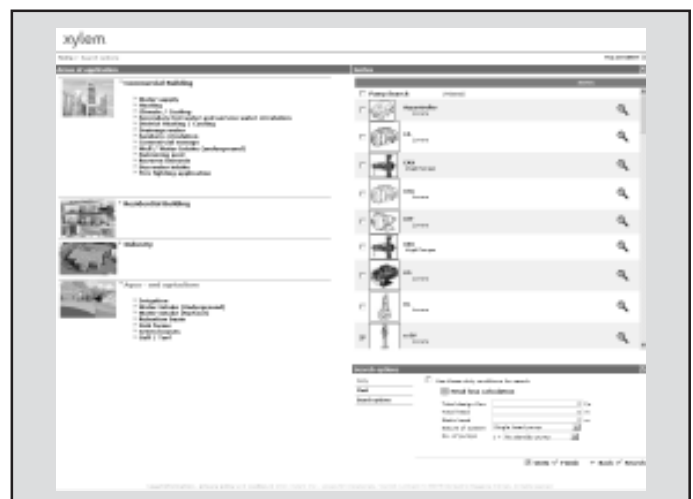

The search by application guides users not familiar with the product range to the right choice.

FURTHER PRODUCT SELECTION AND DOCUMENTATION

Xylect

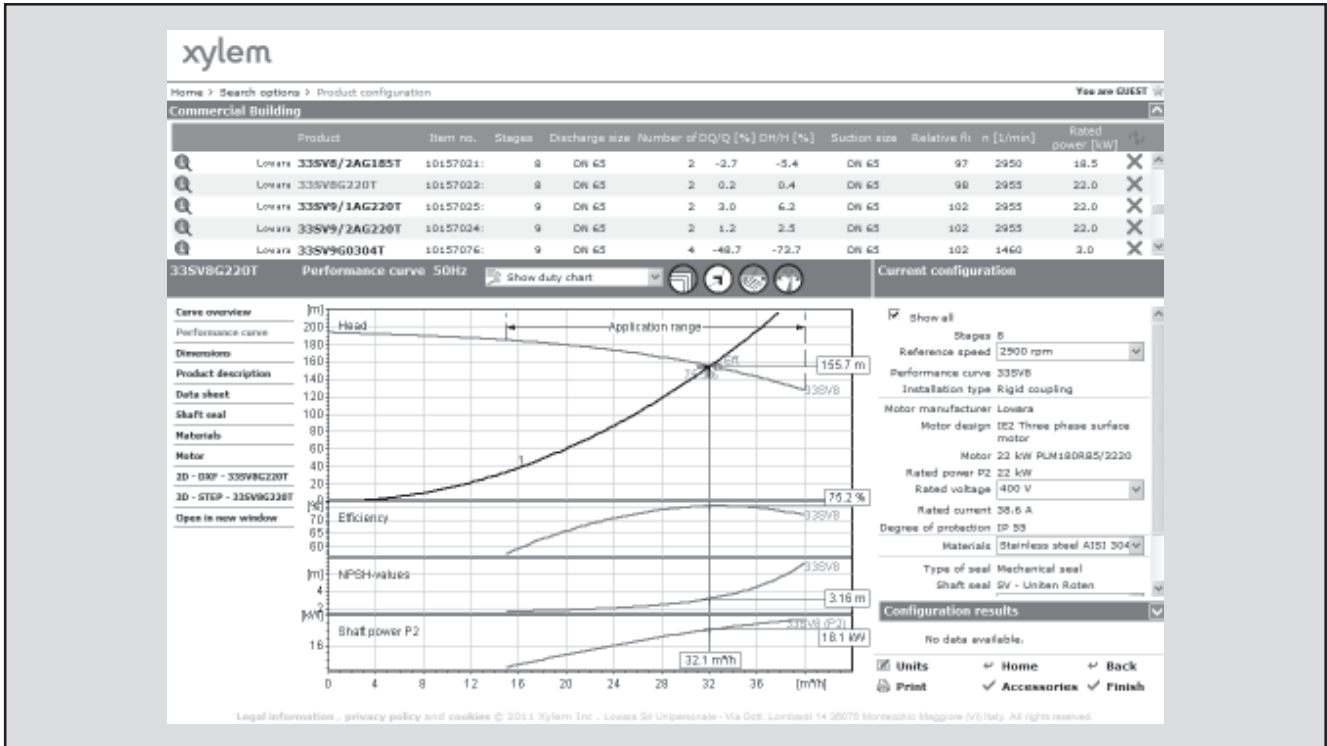

The detailed output makes it easy to select the optimal pump from the given alternatives.

The best way to work with Xylect is to create a personal account. This makes it possible to:

- Set own standard units
- Create and save projects
- Share projects with other Xylect users

Every user have a My Xylect space, where all projects are saved.

For more information about Xylect please contact our sales network or visit www.xylect.com.

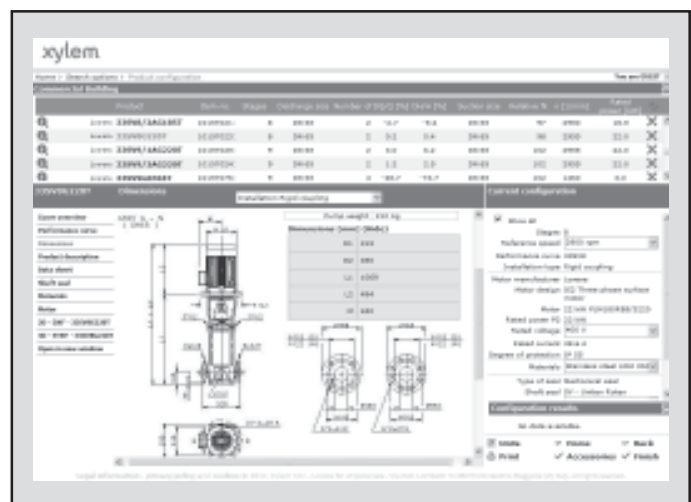

Dimensional drawings appear on the screen and can be downloaded in dxf format.

Blank lined area for technical notes or drawing.

Xylem |'zīləm|

- 1) The tissue in plants that brings water upward from the roots;
- 2) a leading global water technology company.

We're 12,000 people unified in a common purpose: creating innovative solutions to meet our world's water needs. Developing new technologies that will improve the way water is used, conserved, and re-used in the future is central to our work. We move, treat, analyze, and return water to the environment, and we help people use water efficiently, in their homes, buildings, factories and farms. In more than 150 countries, we have strong, long-standing relationships with customers who know us for our powerful combination of leading product brands and applications expertise, backed by a legacy of innovation.

For more information on how Xylem can help you, go to xylem.com.



Headquarters

LOWARA S.r.l. Unipersonale
Via Vittorio Lombardi 14
36075 Montecchio Maggiore - Vicenza - Italy
Tel. (+39) 0444 707111 - Fax (+39) 0444 492166
e-mail: lowara.mkt@xylem.com
web: www.lowara.com - www.completewatersystems.com

LOWARA reserves the right to make modification without prior notice.
LOWARA is a trademark of Xylem Inc. or one of its subsidiaries.